

## MIL CIRCUIT

### CIRCUIT DESCRIPTION

The IG2 relay energized by the power source control ECU applies the battery voltage to the malfunction indicator lamp (MIL) in the combination meter while the main system is turned ON.

When it is necessary, the ECM grounds the W terminal line and illuminates the MIL.

In order to perform functional check visually, the MIL is illuminated when the power switch is first turned ON. If the MIL is ON or OFF all of the time, use the procedure below to troubleshoot it. The MIL is used to indicate vehicle malfunction which was detected by the ECM. Follow this procedure using the hand-held tester or the OBD II scan tool to determine cause of the problem and to check the MIL.



# INSPECTION PROCEDURE

**HINT:**

Troubleshoot each trouble symptom in accordance with the chart below .

MIL remains on	Start inspection from step 1
MIL is not illuminated	Start inspection from step 3

**1 CLEAR DTC**

- (a) Connect the hand-held tester or the OBD II scan tool to the DLC 3.
- (b) Turn the power switch ON (IG).
- (c) Turn the hand-held tester or the OBD II scan tool ON.
- (d) Read DTCs (See page 05-41).
- (e) Clear the DTCs (See page 05-41).
- (f) Check that MIL is not illuminated.

**Standard: MIL is not illuminated.**

**OK** REPAIR CIRCUIT INDICATED BY OUTPUT CODE (See page 05-55)

**NG**

**2 CHECK HARNESS AND CONNECTOR(CHECK FOR SHORT IN WIRE HARNESS)**

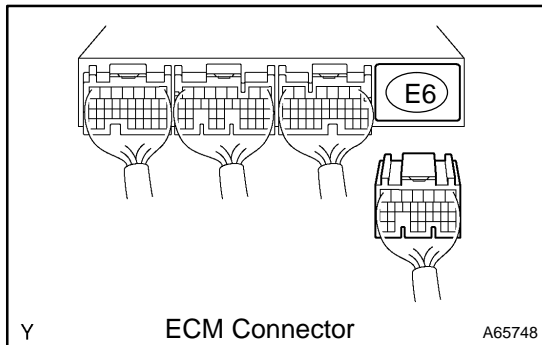

- (a) Disconnect the E6 ECM connector.
  - (b) Turn the power switch ON (IG).
  - (c) Check that MIL is not illuminated.
- Standard: MIL is not illuminated.**
- (d) Reconnect the ECM connector.

**OK** REPLACE ECM (See page 10-24)

**NG**

**CHECK AND REPAIR HARNESS AND CONNECTOR (COMBINATION METER - ECM)**

**3 CHECK THAT MIL IS ILLUMINATED**

- (a) Check that MIL is illuminated when the power switch is turned ON (IG).

**Standard: MIL is illuminated.**

**OK** SYSTEM OK

**NG**

**4 INSPECT COMBINATION METER ECU (MIL CIRCUIT)**

(a) See the combination meter troubleshooting on page [05-1986](#).

**NG****REPAIR OR REPLACE BULB OR COMBINATION  
METER ASSEMBLY****OK****CHECK AND REPAIR HARNESS AND CONNECTOR (COMBINATION METER - ECM)**