

<b>DTC</b>	<b>B1423</b>	<b>PRESSURE SWITCH CIRCUIT</b>
------------	--------------	--------------------------------

**CIRCUIT DESCRIPTION**

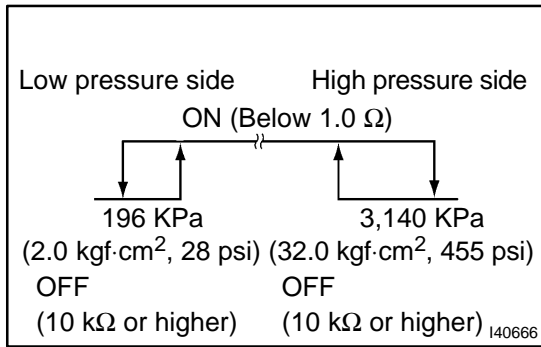

The pressure switch to detect the refrigerant pressure is located in the sight glass side of the pipe on the high-pressure side. This DTC is output when the refrigerant pressure is either significantly low (below 196 kPa (2.0 kgf/cm<sup>2</sup>, 28 psi) or significantly high (over 3,140 kPa (32.0 kgf/cm<sup>2</sup>, 455 psi)). Then the pressure switch sends appropriate signals to the A/C amplifier. The pressure switch has built-in switches to detect high and low pressure and is turned off when either is determined to be defective. The A/C amplifier continuously monitors the pressure switch signal after the power switch is turned on. It stops compressor control and output the DTC when it detects the signal indicating that the switch is turned off.

DTC No.	Detection Item	Trouble Area
B1423	<ul style="list-style-type: none"> <li>• Open in pressure sensor circuit.</li> <li>• Abnormal refrigerant pressure. below 196 kPa (2.0 kgf/cm<sup>2</sup>, 28 psi) over 3,140 kPa (32.0 kgf/cm<sup>2</sup>, 455 psi)</li> </ul>	<ul style="list-style-type: none"> <li>• Pressure switch</li> <li>• Harness or connector between pressure switch and body ground</li> <li>• Multiplex communication circuit</li> <li>• Refrigerant pipe line</li> <li>• A/C amplifier</li> </ul>

**WIRING DIAGRAM**

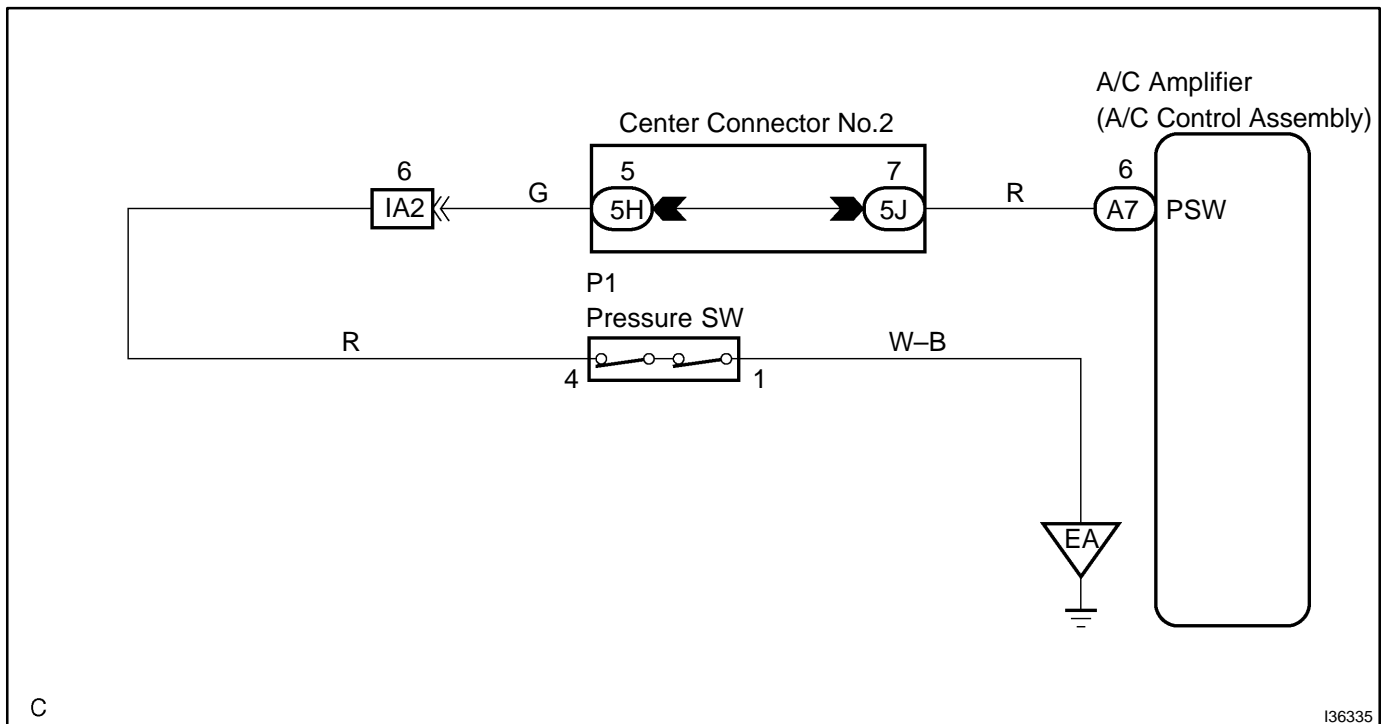

C

## INSPECTION PROCEDURE

### 1 INSPECT REFRIGERANT PRESSURE

- Set the manifold gauge.
- Read the manifold gauge pressure when these conditions are established.

Test conditions:

- Temperature at the air inlet with the switch set at RECIRC is 30 to 35°C (86 to 95°F)
- Power switch ON (ON)
- Blower speed control switch at "HI" position
- Temperature control dial at "COOL" position
- Air conditioning switch ON
- Fully open doors

**Standard:**

**Pressure on high pressure side:**

**1.37 to 1.57 MPa (13.9 to 16.0 kgf·cm<sup>2</sup>, 198 to 228 psi)**

**HINT:**

If the refrigerant pressure is below 196 KPa (2.0 kgf·cm<sup>2</sup>, 28 psi), the refrigerant amount in the air conditioning cycle may have decreased significantly for reasons such as a gas leakage.

**NG**

**INSPECT AND REPAIR AIR CONDITIONING CYCLE (SEE PAGE 55-12)**

**OK**

### 2 CHECK AIR CONDITIONING OPERATION

**Pressure Switch Connector  
Front View:**

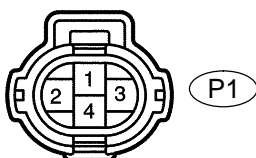

140669

- Disconnect the connector from pressure switch.
- Connect terminals 1 and 4 of the connector of the pressure switch on the vehicle wire harness side using a service wire.
- Power switch ON (ON).
- Turn the air conditioning switch on and check that the compressor is operated.
- Check that the compressor is not operated when disconnecting terminals 1 and 4 (that were connected in the prior step).

**OK:**

**Terminals 1 and 4 connected: the compressor is operated**

**Terminals 1 and 4 disconnected: the compressor is not operated**

**NG**

**Go to step 3**

**OK**

### REPLACE PRESSURE SWITCH (COOLER CONDENSER ASSY)

**3 CHECK HARNESS AND CONNECTOR(PRESSURE SWITCH – AIR CONDITIONING AMPLIFIER) (SEE PAGE 01-47)**

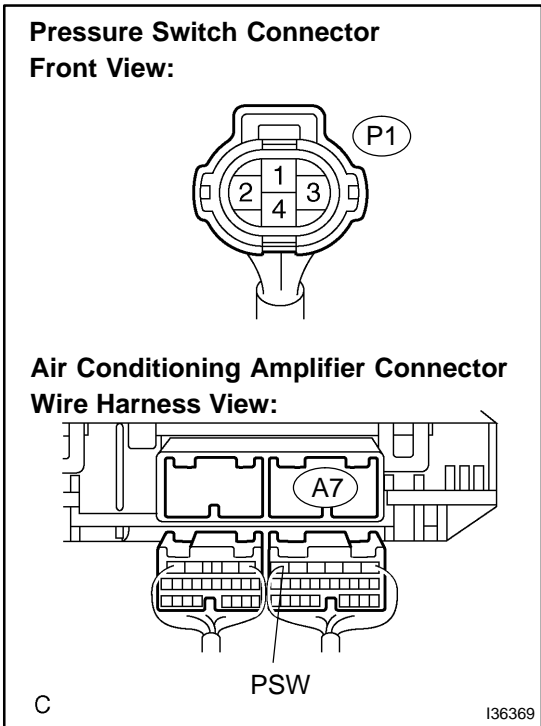

- (a) Disconnect the connector from pressure switch.
- (b) Measure the resistance according to the value(s) in the table below.

**Standard:**

Tester connection	Condition	Specified condition
A7-6 (PSW) – P1-4	Always	Below 1 Ω
P1-1 – Body ground	Always	Below 1 Ω
A7-6 (PSW) – Body ground	Always	10 kΩ or higher

**Result:**

NG	A
OK (Checking from the PROBLEM SYMPTOMS TABLE)	B
OK (Checking from the DTC)	C

**A** → **REPAIR OR REPLACE HARNESS OR CONNECTOR**

**B** → **PROCEED TO NEXT CIRCUIT INSPECTION SHOWN IN PROBLEM SYMPTOMS TABLE (SEE PAGE 05-1268)**

**C**

**REPLACE AIR CONDITIONING AMPLIFIER (SEE PAGE 55-47)**