

SPEAKER CIRCUIT

CIRCUIT DESCRIPTION

The sound signal that has been amplified by the stereo component amplifier is sent to the speaker from the stereo component amplifier through this circuit.

As for the vehicle with a navigation system, the sound signal on the driver's side is sent to the navigation ECU from the stereo component amplifier.

If there is a short in this circuit, the stereo component amplifier assy detects it and stops output to the speaker. Thus sound can not be heard from the speaker even if there is no malfunction in the stereo component amplifier assy or speaker.

Built-in type amplifier:

There are two circuits that detect a short circuit.

- When a short in the woofer speaker circuit is detected, sound output from only the woofer speaker circuit stops.
- When a short in the other circuits is detected, sound output from the circuits other than the woofer speaker circuit is stopped.

Separate type amplifier:

When a short in the speaker circuit is detected, all sound output is stopped.

WIRING DIAGRAM

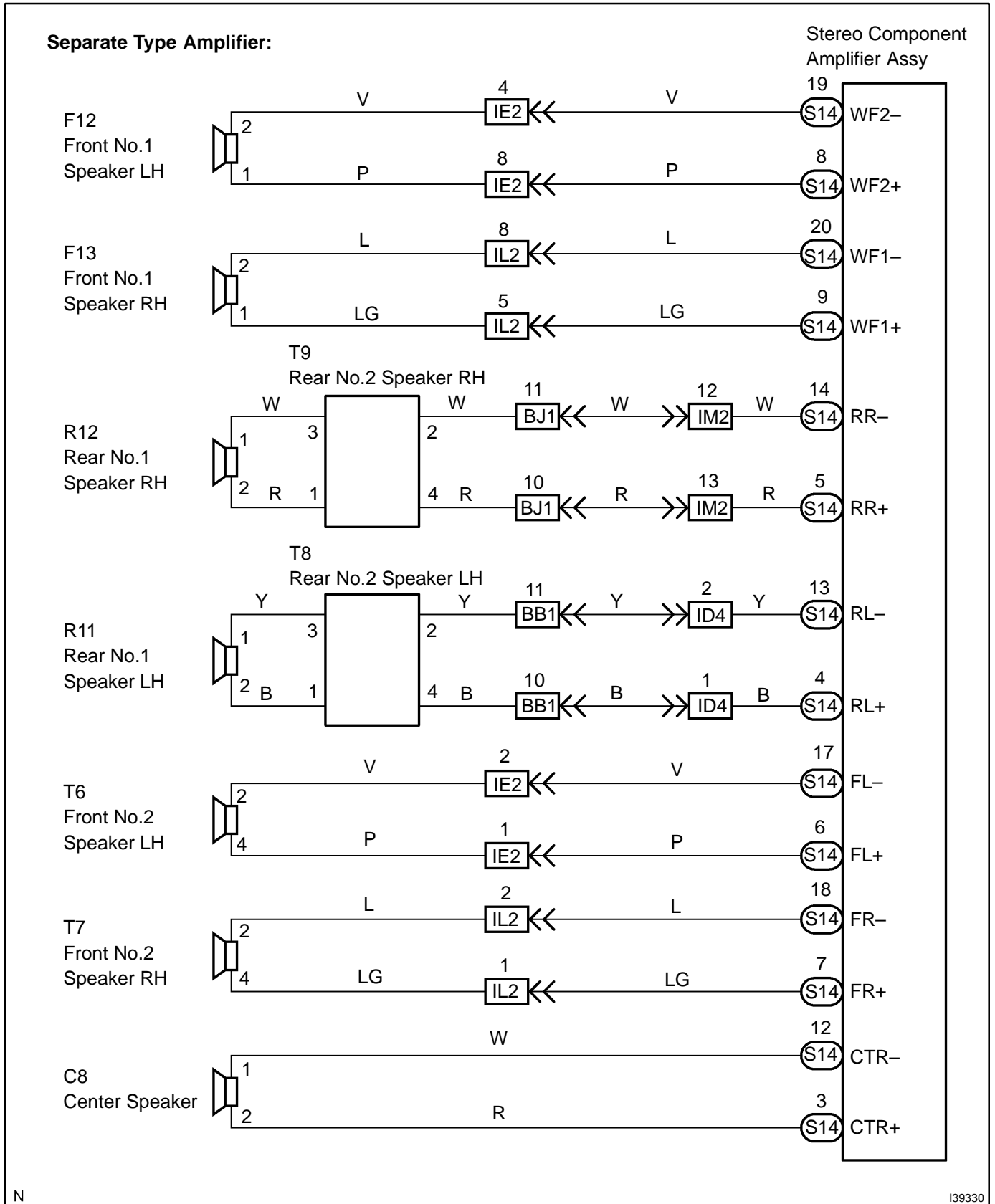

N

I39330

Built-in Type Amplifier:

Radio Receiver Assy

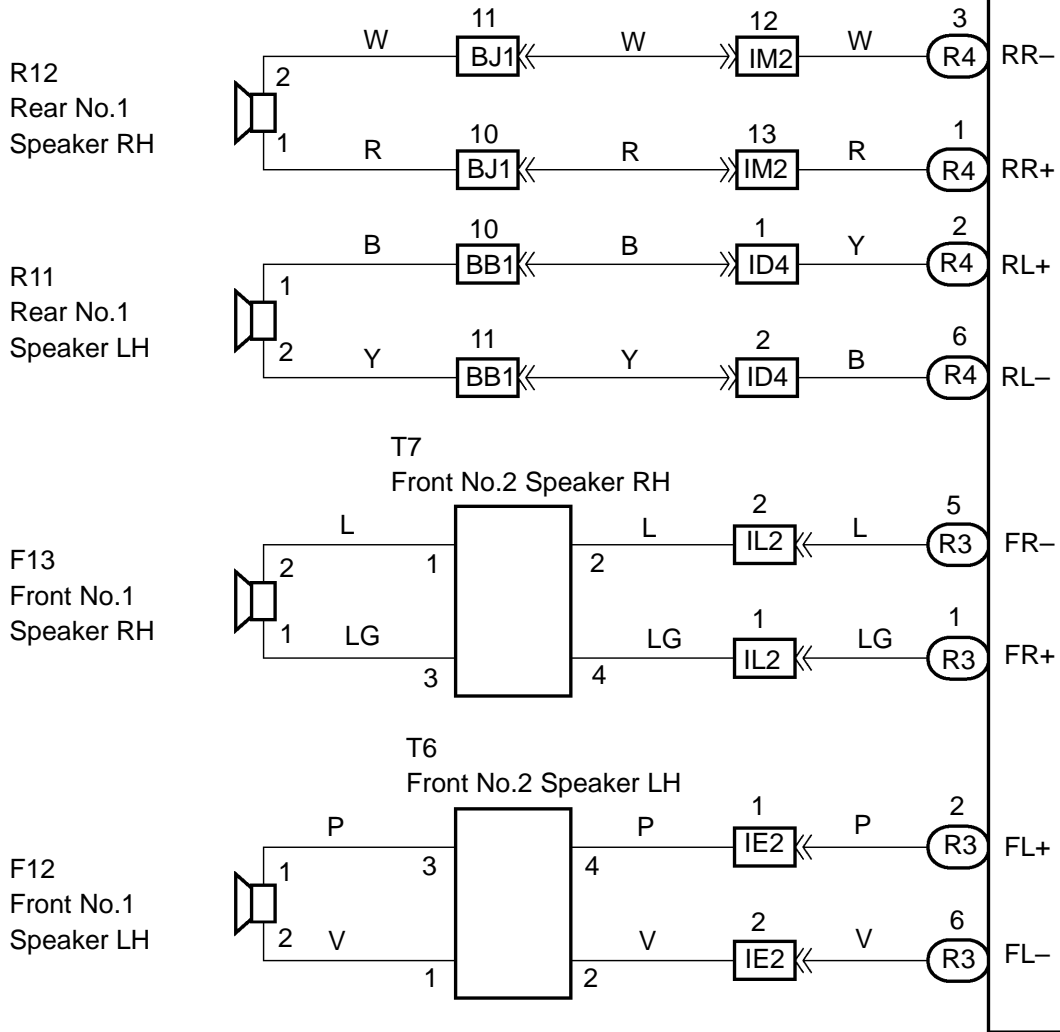

C

I39046

INSPECTION PROCEDURE

1 CHECK HARNESS AND CONNECTOR

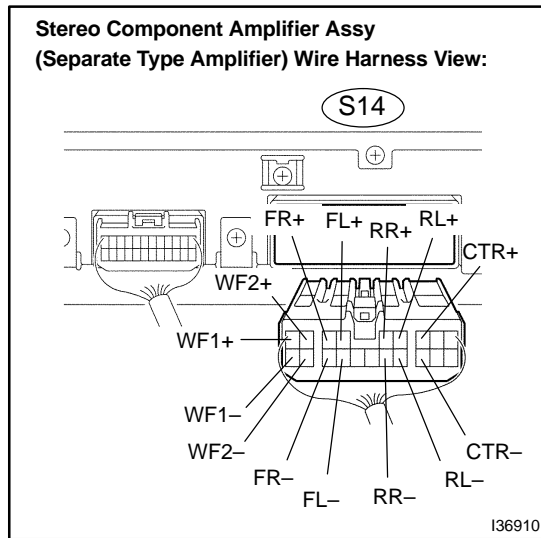

- (a) Disconnect the connectors shown in the illustration on the left from the stereo component amplifier assy and speakers.
- (b) Measure the resistance between the speaker and the stereo component amplifier assy or the radio receiver assy to check for an open circuit in the wire harness.

Standard:

Below 1 Ω

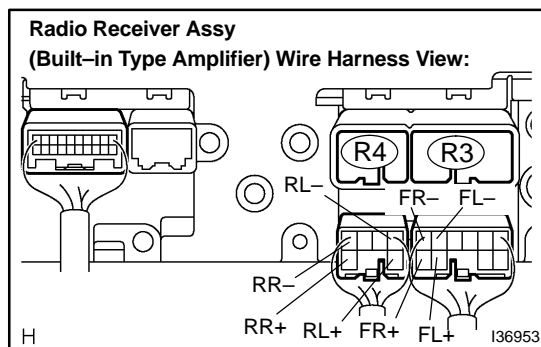

- (c) Measure the resistance between the speaker and body ground to check for a short circuit in the wire harness.

Standard:

10 k Ω or higher

Center Speaker Assy (Wire Harness Side)
Connector Front View:

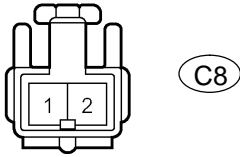

Front No.1 Speaker Assy (Wire Harness Side)
Connector Front View:

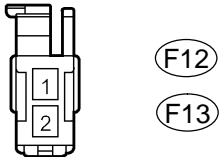

Front No.2 Speaker Assy (Wire Harness Side)
Connector Front View:

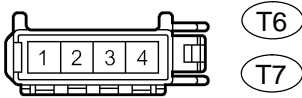

Rear No.1 Speaker Assy (Wire Harness Side)
Connector Front View:

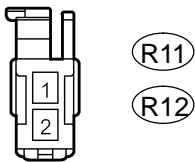

Rear No.2 Speaker Assy (Wire Harness Side)
Connector Front View:

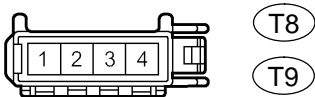

H I39338

NG → REPAIR OR REPLACE HARNESS OR CONNECTOR

OK

2 INSPECT FRONT NO.1 SPEAKER ASSY

- (a) Resistance check.
 - (1) Measure the resistance between the terminals of the speaker.

Standard:
 Separate Type Amplifier: 1.8 to 2.6 Ω
 Built-in Type Amplifier: APPROX. 4 Ω

NG → REPLACE FRONT NO.1 SPEAKER ASSY (SEE PAGE 67-8)

OK

3	INSPECT FRONT NO.2 SPEAKER ASSY
----------	--

(a) Check that malfunction disappears when another speaker in good condition is installed.

OK: Malfunction disappears.

HINT:

- Connect all the connectors to the speakers.
- When there is a possibility that either right or left front speaker is defective, inspect by interchanging the right one and the left one.

NG

**REPLACE FRONT NO.2 SPEAKER ASSY
(SEE PAGE 67-10)**

OK

4	INSPECT REAR NO.1 SPEAKER ASSY
----------	---------------------------------------

(a) Resistance check.

(1) Measure the resistance between the terminals of the speaker.

Standard:

Separate Type Amplifier: APPROX. 2.6 Ω

Built-in Type Amplifier: APPROX. 4 Ω

NG

**REPLACE REAR NO.1 SPEAKER ASSY
(SEE PAGE 67-12)**

OK

5	CONFIRM MODEL
----------	----------------------

Result:

Separate Type Amplifier	A
Built-in Type Amplifier	B

B

**PROCEED TO NEXT CIRCUIT INSPECTION
SHOWN IN PROBLEM SYMPTOMS TABLE
(SEE PAGE 05-1778)**

A

6	INSPECT REAR NO.2 SPEAKER ASSY
----------	---------------------------------------

(a) Resistance check.

(1) Measure the resistance between the terminals of the speaker.

Standard: APPROX. 4 Ω

NG

**REPLACE REAR NO.2 SPEAKER ASSY
(SEE PAGE 67-14)**

OK

7 INSPECT CENTER SPEAKER

- (a) Resistance check.
(1) Measure the resistance between the terminals of the speaker.

Standard: 1.2 to 2.2 Ω

NG

**REPLACE CENTER SPEAKER
(SEE PAGE 67-11)**

OK

**PROCEED TO NEXT CIRCUIT INSPECTION SHOWN IN PROBLEM SYMPTOMS TABLE
(SEE PAGE 05-1778)**