

STEERING PAD SWITCH CIRCUIT

CIRCUIT DESCRIPTION

This circuit sends an operation signal from the steering pad switch to the radio receiver assy. If there is an open in the circuit, the audio system cannot be operated by the steering pad switch. If there is a short in the circuit, the same condition as that when the switch is continuously depressed occurs. Therefore, not only the steering pad switch cannot operate the radio receiver assy, but also the radio receiver assy itself does not function.

WIRING DIAGRAM

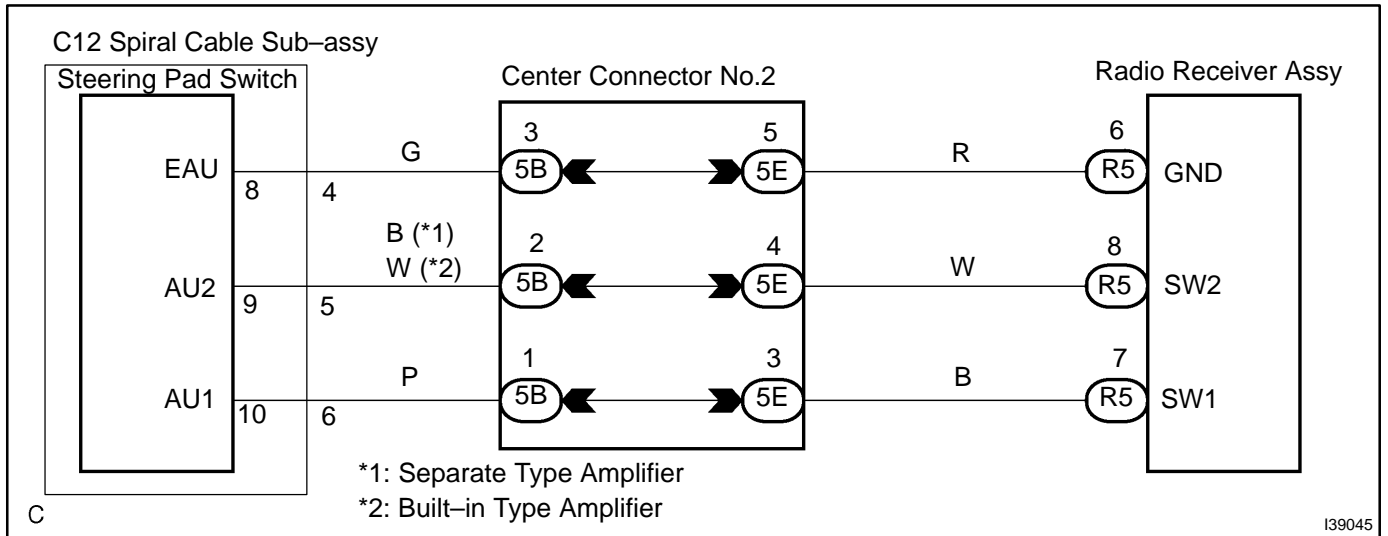

INSPECTION PROCEDURE

1 INSPECT STEERING PAD SWITCH ASSY

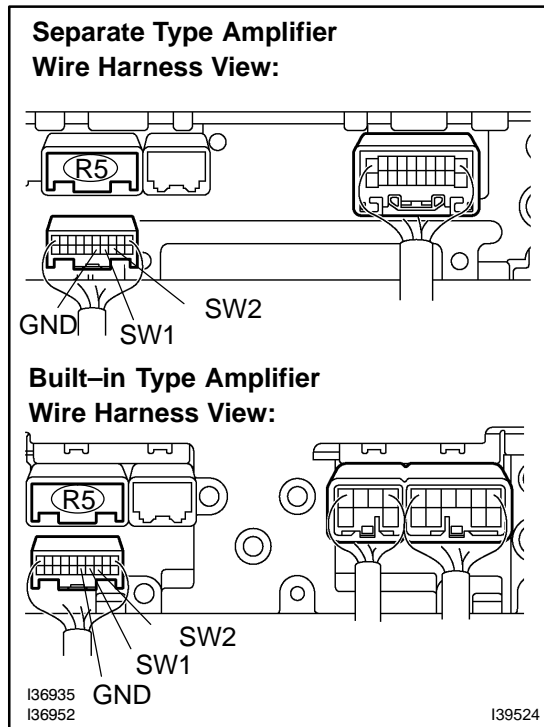

- (a) Disconnect the radio receiver assy R5 connector.
- (b) Measure the resistance according to the values in the table below.

Standard:

Tester connection	Condition	Specified condition
SW1 (R5-7) – GND (R5-6)	Do not switch position	Approx. 100 kΩ
SW1 (R5-7) – GND (R5-6)	SEEK+ switch: push	Below 2.5 Ω
SW1 (R5-7) – GND (R5-6)	SEEK- switch: push	Approx. 0.3 kΩ
SW1 (R5-7) – GND (R5-6)	VOL+ switch: push	Approx. 1 kΩ
SW1 (R5-7) – GND (R5-6)	VOL- switch: push	Approx. 3.2 kΩ
SW2 (R5-8) – GND (R5-6)	Do not switch position	Approx. 100 kΩ
SW2 (R5-8) – GND (R5-6)	MODE switch: push	Below 2.5 Ω

NG Go to step 2

OK

PROCEED TO NEXT CIRCUIT INSPECTION SHOWN ON PROBLEM SYMPTOMS TABLE (SEE PAGE 05-1778)

2 INSPECT STEERING PAD SWITCH ASSY

Steering Pad Switch Assy:

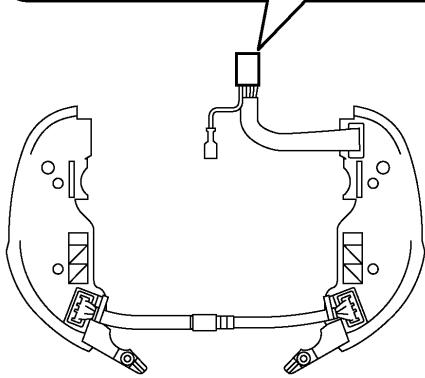
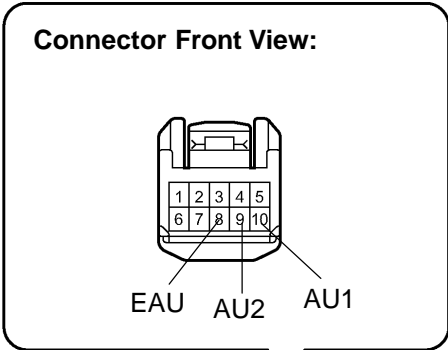

H

I39336

- (a) Disconnect the steering pad switch assy connector.
- (b) Measure the resistance according to the values in the table below.

Standard:

Tester connection	Condition	Specified condition
AU1 (10) – EAU (8)	Do not switch position	Approx. 100 kΩ
AU1 (10) – EAU (8)	SEEK+ switch: push	Approx. 2.5 Ω
AU1 (10) – EAU (8)	SEEK- switch: push	Approx. 0.3 kΩ
AU1 (10) – EAU (8)	VOL+ switch: push	Approx. 1 kΩ
AU1 (10) – EAU (8)	VOL- switch: push	Approx. 3.2 kΩ
AU1 (10) – EAU (8)	Do not switch position	Approx. 100 kΩ
AU2 (9) – EAU (8)	MODE switch: push	Below 2.5 Ω

NG REPLACE STEERING PAD SWITCH ASSY (SEE PAGE 67-28)

OK

3 INSPECT SPIRAL CABLE SUB-ASSY

Steering Pad Switch Assy Side:

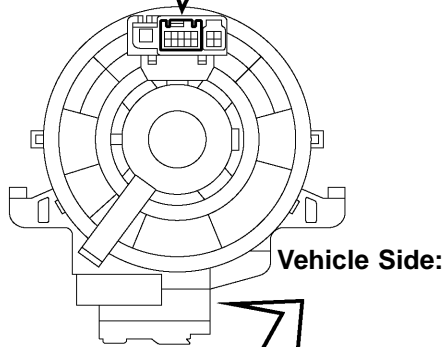
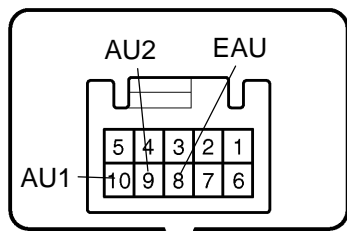

Vehicle Side:

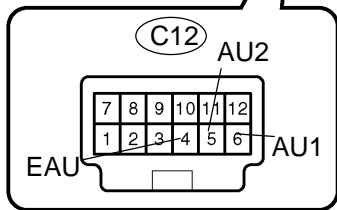

N

I39337

- (a) Disconnect the connectors from the spiral cable sub-assy.
- (b) Measure the resistance according to the values in the table below.

Standard:

Tester connection	Specified condition
EAU (C12-4) – EAU (8)	Below 1 Ω
AU1 (C12-6) – AU1 (10)	Below 1 Ω
AU2 (C12-5) – AU2 (9)	Below 1 Ω

NG **REPLACE SPIRAL CABLE SUB-ASSY (SEE PAGE 60-29)**

OK

4 CHECK HARNESS AND CONNECTOR(SPIRAL CABLE SUB-ASSY - RADIO RECEIVER ASSY)

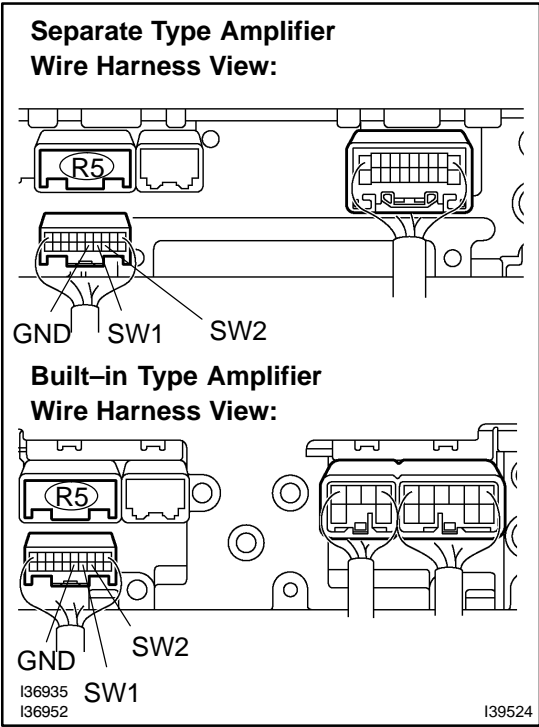

- (a) Disconnect the spiral cable sub-assy connector.
- (b) Measure the resistance according to the values in the table below.

Standard:

Tester connection	Specified condition
SW1 (R5-7) - AU1 (C12-6)	Below 1 Ω
SW2 (R5-8) - AU2 (C12-5)	Below 1 Ω
GND (R5-6) - EAU (C12-4)	Below 1 Ω
SW1 (R5-7) - Body ground	10 kΩ or higher
SW2 (R5-8) - Body ground	10 kΩ or higher
GND (R5-6) - Body ground	10 kΩ or higher

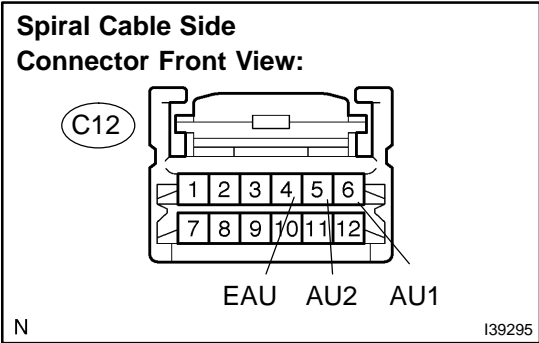

NG REPAIR OR REPLACE HARNESS OR CONNECTOR

OK

PROCEED TO NEXT CIRCUIT INSPECTION SHOWN ON PROBLEM SYMPTOMS TABLE (SEE PAGE 05-1778)