

DTC	B1818/54	SHORT IN P SQUIB (DUAL STAGE – 2ND STEP) CIRCUIT (TO B+)
------------	-----------------	---

CIRCUIT DESCRIPTION

The P squib (Dual stage – 2nd step) circuit consists of the airbag ECU assy and the front passenger airbag assy.

The circuit instructs the SRS to deploy when deployment conditions are met.

DTC B1818 is recorded when a short to B+ is detected in the P squib (Dual stage – 2nd step) circuit.

DTC No.	DTC Detecting Condition	Trouble Area
B1818	<ul style="list-style-type: none"> • When the airbag ECU assy receives a B+ short signal in the P squib (Dual stage – 2nd step) circuit for 0.5 seconds. • P squib (Dual stage – 2nd step) malfunction • Airbag ECU assy malfunction 	<ul style="list-style-type: none"> • Instrument panel wire • Instrument panel wire No.2 • Front passenger airbag assy (P squib, Dual stage – 2nd step) • Airbag ECU assy

WIRING DIAGRAM

See page [05-1481](#).

INSPECTION PROCEDURE

CAUTION:

Be sure to perform the following procedures before troubleshooting to avoid unexpected airbag deployment.

- (a) Turn the power switch off.
- (b) Disconnect the negative (–) terminal cable from the battery, and wait for at least 90 seconds.
- (c) Disconnect the connectors from the airbag ECU Assy.
- (d) Disconnect the connectors from the horn button Assy.
- (e) Disconnect the connectors from the front passenger airbag Assy.
- (f) Disconnect the connector from the front seat airbag Assy LH.
- (g) Disconnect the connector from the front seat airbag Assy RH.
- (h) Disconnect the connector from the curtain shield airbag Assy LH.
- (i) Disconnect the connector from the curtain shield airbag Assy RH.
- (j) Disconnect the connector from the front seat outer belt Assy LH.
- (k) Disconnect the connector from the front seat outer belt Assy RH.

1 CHECK P SQUIB (DUAL STAGE – 2ND STEP) CIRCUIT(AIRBAG ECU ASSY – FRONT PASSENGER AIRBAG ASSY)

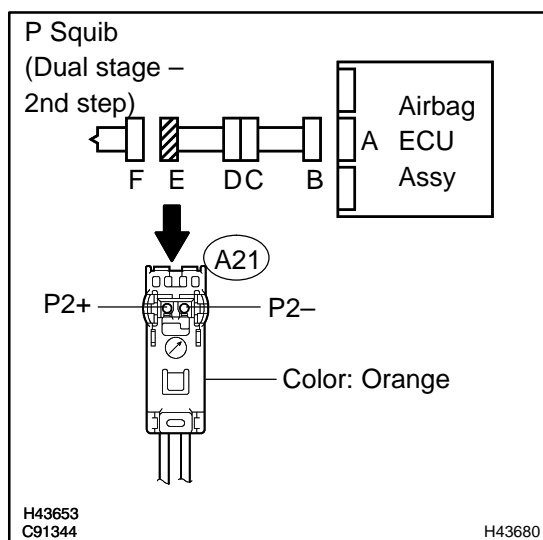

- (a) Connect the negative (–) terminal cable to the battery, and wait for at least 2 seconds.
- (b) Turn the power switch on (IG).
- (c) Measure the voltage according to the value(s) in the table below.

Standard:

Tester connection	Condition	Specified condition
A21–1 (P2+) – Body ground	Power switch is on (IG)	Below 1 V
A21–2 (P2–) – Body ground	Power switch is on (IG)	Below 1 V

NG

Go to step 4

OK

2 CHECK AIR BAG ECU ASSY

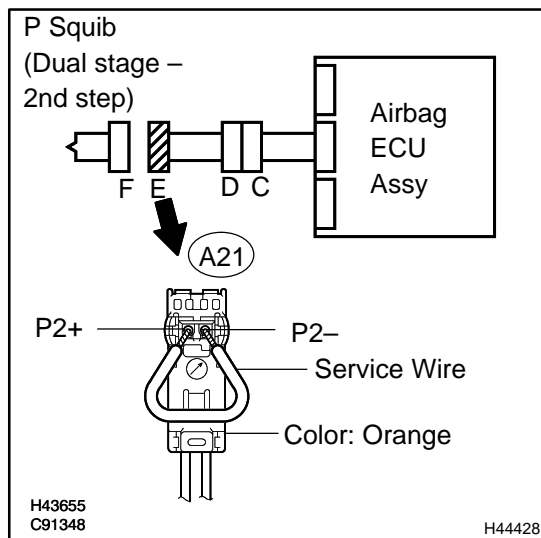

- (a) Turn the power switch off.
- (b) Disconnect the negative (-) terminal cable from the battery, and wait for at least 90 seconds.
- (c) Connect the connectors to the airbag ECU assy.
- (d) Using a service wire, connect A21-1 (P2+) and A21-2 (P2-) of connector "E".

NOTICE:

- **Twist the end of the service wire in order to insert it into the connector.**
 - **Do not forcibly insert the twisted service wire into the terminals of the connector when connecting.**
- (e) Connect the negative (-) terminal cable to the battery, and wait for at least 2 seconds.
 - (f) Turn the power switch on (IG), and wait for at least 60 seconds.
 - (g) Clear the DTCs stored in memory (see page 05-1402).
 - (h) Turn the power switch off.
 - (i) Turn the power switch on (IG), and wait for at least 60 seconds.
 - (j) Check the DTCs (see page 05-1402).

OK:

DTC B1818 is not output.

HINT:

Codes other than code B1818 may be output at this time, but they are not related to this check.

NG

**REPLACE AIR BAG ECU ASSY
(SEE PAGE 60-54)**

OK

3 CHECK FRONT PASSENGER AIRBAG ASSY(P SQUIB (DUAL STAGE – 2ND STEP))

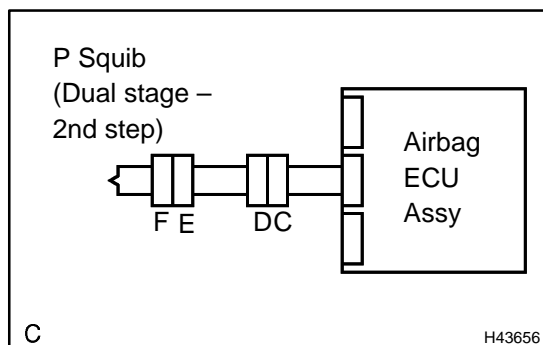

- (a) Turn the power switch off.
- (b) Disconnect the negative (–) terminal cable from the battery, and wait for at least 90 seconds.
- (c) Disconnect the service wire from connector "E".
- (d) Connect the connectors to the front passenger airbag assy.
- (e) Connect the negative (–) terminal cable to the battery, and wait for at least 2 seconds.
- (f) Turn the power switch on (IG), and wait for at least 60 seconds.
- (g) Clear the DTCs stored in memory (see page 05-1402).
- (h) Turn the power switch off.
- (i) Turn the power switch on (IG), and wait for at least 60 seconds.
- (j) Check the DTCs (see page 05-1402).

OK:

DTC B1818 is not output.

HINT:

Codes other than code B1818 may be output at this time, but they are not related to this check.

NG

**REPLACE FRONT PASSENGER AIRBAG ASSY
(SEE PAGE 60-32)**

OK

USE SIMULATION METHOD TO CHECK (SEE PAGE 05-1397)

HINT:

- Perform the simulation method by selecting the check mode with the hand-held tester (see page 05-1405).
- After selecting the check mode, perform the simulation method by wiggling each connector of the airbag system or driving the vehicle on a city or rough road (see page 05-1405).

4 CHECK INSTRUMENT PANEL WIRE

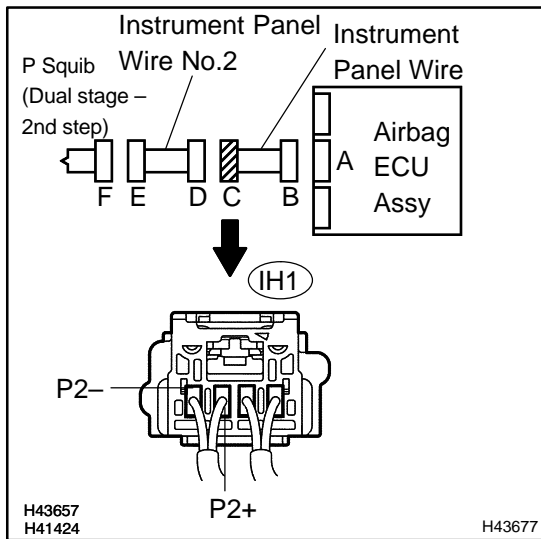

- (a) Turn the power switch off.
- (b) Disconnect the negative (-) terminal cable from the battery, and wait for at least 90 seconds.
- (c) Disconnect the instrument panel wire connector from the instrument panel wire No.2.
- (d) Connect the negative (-) terminal cable to the battery, and wait for at least 2 seconds.
- (e) Turn the power switch on (IG).
- (f) Measure the voltage according to the value(s) in the table below.

Standard:

Tester connection	Condition	Specified condition
IH1-3 (P2+) - Body ground	Power switch is on (IG)	Below 1 V
IH1-4 (P2-) - Body ground	Power switch is on (IG)	Below 1 V

NG REPAIR OR REPLACE INSTRUMENT PANEL WIRE

OK

5 CHECK INSTRUMENT PANEL WIRE NO.2

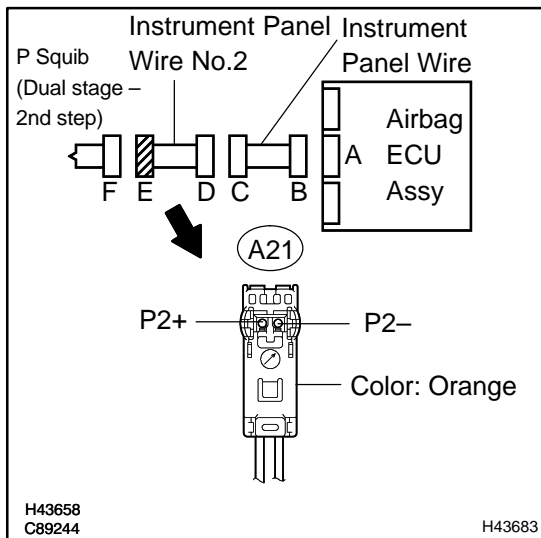

- (a) Measure the voltage according to the value(s) in the table below when the power switch is on (IG).

Standard:

Tester connection	Condition	Specified condition
A21-1 (P2+) - Body ground	Power switch is on (IG)	Below 1 V
A21-2 (P2-) - Body ground	Power switch is on (IG)	Below 1 V

NG REPAIR OR REPLACE INSTRUMENT PANEL WIRE NO.2

OK

USE SIMULATION METHOD TO CHECK (SEE PAGE 05-1397)

HINT:

- Perform the simulation method by selecting the check mode with the hand-held tester (see page 05-1405).
- After selecting the check mode, perform the simulation method by wiggling each connector of the air-bag system or driving the vehicle on a city or rough road (see page 05-1405).