

DTC	B1802/51	SHORT IN D SQUIB CIRCUIT (TO GROUND)
------------	-----------------	---

CIRCUIT DESCRIPTION

The D squib circuit consists of the airbag ECU Assy, the spiral cable sub-assy and the horn button Assy. The circuit instructs the SRS to deploy when deployment conditions are met.

DTC B1802 is recorded when a short to ground is detected in the D squib circuit.

DTC No.	DTC Detecting Condition	Trouble Area
B1802	<ul style="list-style-type: none"> • When the airbag ECU Assy receives a short to ground signal in the D squib circuit for 0.5 seconds. • D squib malfunction • Spiral cable sub-assy malfunction • Airbag ECU Assy malfunction 	<ul style="list-style-type: none"> • Instrument panel wire • Spiral cable sub-assy • Horn button Assy (D squib) • Airbag ECU Assy

WIRING DIAGRAM

See page [05-1461](#).

INSPECTION PROCEDURE

CAUTION:

Be sure to perform the following procedures before troubleshooting to avoid unexpected airbag deployment.

- (a) Turn the power switch off.
- (b) Disconnect the negative (-) terminal cable from the battery, and wait for at least 90 seconds.
- (c) Disconnect the connectors from the airbag ECU assy.
- (d) Disconnect the connectors from the horn button assy.
- (e) Disconnect the connectors from the front passenger airbag assy.
- (f) Disconnect the connector from the front seat airbag assy LH.
- (g) Disconnect the connector from the front seat airbag assy RH.
- (h) Disconnect the connector from the curtain shield airbag assy LH.
- (i) Disconnect the connector from the curtain shield airbag assy RH.
- (j) Disconnect the connector from the front seat outer belt assy LH.
- (k) Disconnect the connector from the front seat outer belt assy RH.

1 CHECK D SQUIB CIRCUIT(AIRBAG ECU ASSY – HORN BUTTON ASSY)

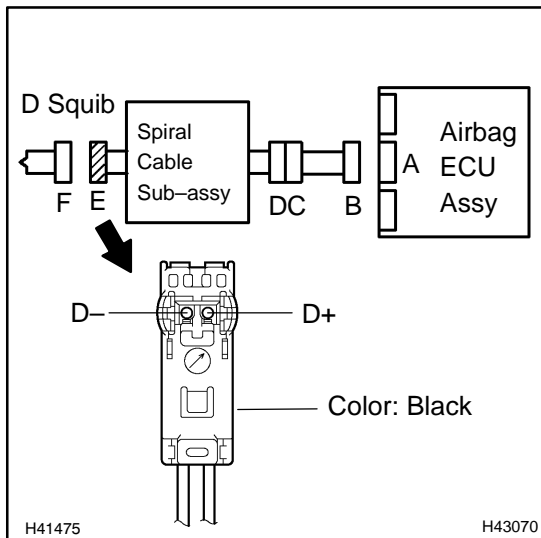

- (a) Measure the resistance according to the value(s) in the table below.

Standard:

Tester connection	Condition	Specified condition
D+ – Body ground	Always	1 MΩ or Higher
D- – Body ground	Always	1 MΩ or Higher

OK

NG Go to step 4

2 CHECK AIR BAG ECU ASSY

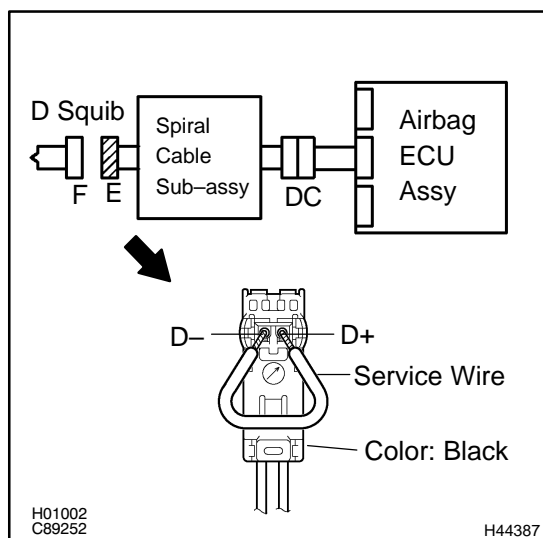

- (a) Connect the connectors to the airbag ECU assy.
- (b) Using a service wire, connect D+ and D- of connector "E".

NOTICE:

- **Twist the end of the service wire in order to insert it into the connector.**
 - **Do not forcibly insert the twisted service wire into the terminals of the connector when connecting.**
- (c) Connect the negative (-) terminal cable to the battery, and wait for at least 2 seconds.
 - (d) Turn the power switch on (IG), and wait for at least 60 seconds.
 - (e) Clear the DTCs stored in memory (see page 05-1402).
 - (f) Turn the power switch off.
 - (g) Turn the power switch on (IG), and wait for at least 60 seconds.
 - (h) Check the DTCs (see page 05-1402).

OK:

DTC B1802 is not output.

HINT:

Codes other than code B1802 may be output at this time, but they are not related to this check.

NG

**REPLACE AIR BAG ECU ASSY
(SEE PAGE 60-54)**

OK

3 CHECK HORN BUTTON ASSY(D SQUIB)

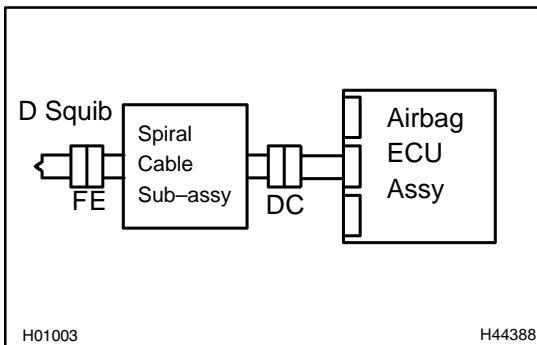

- (a) Turn the power switch off.
- (b) Disconnect the negative (-) terminal cable from the battery, and wait for at least 90 seconds.
- (c) Disconnect the service wire from connector "E".
- (d) Connect the connectors to the horn button assy.
- (e) Connect the negative (-) terminal cable to the battery, and wait for at least 2 seconds.
- (f) Turn the power switch on (IG), and wait for at least 60 seconds.
- (g) Clear the DTCs stored in memory (see page 05-1402).
- (h) Turn the power switch off.
- (i) Turn the power switch on (IG), and wait for at least 60 seconds.
- (j) Check the DTCs (see page 05-1402).

OK:

DTC B1802 is not output.

HINT:

Codes other than code B1802 may be output at this time, but they are not related to this check.

NG

**REPLACE HORN BUTTON ASSY
(SEE PAGE 60-20)**

OK

USE SIMULATION METHOD TO CHECK (SEE PAGE 05-1397)

HINT:

- Perform the simulation method by selecting the check mode with the hand-held tester (see page 05-1405).
- After selecting the check mode, perform the simulation method by wiggling each connector of the airbag system or driving the vehicle on a city or rough road (see page 05-1405).

4 CHECK INSTRUMENT PANEL WIRE

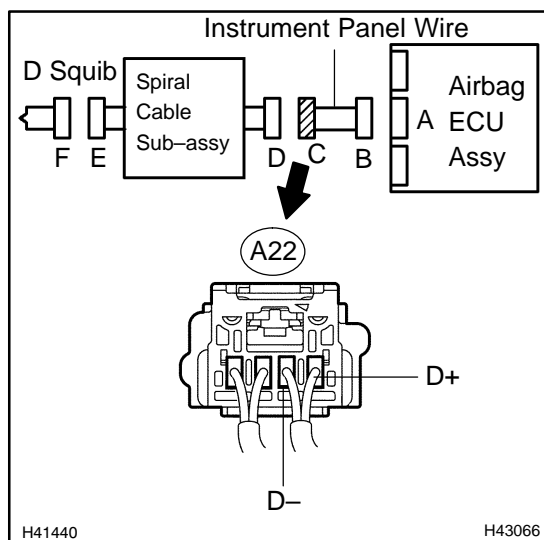

- Disconnect the instrument panel wire connector from the spiral cable sub-assy.
- Measure the resistance according to the value(s) in the table below.

Standard:

Tester connection	Condition	Specified condition
A22-1 (D+) – Body ground	Always	1 MΩ or Higher
A22-2 (D-) – Body ground	Always	1 MΩ or Higher

NG
REPAIR OR REPLACE INSTRUMENT PANEL WIRE
OK

5 CHECK SPIRAL CABLE SUB-ASSY

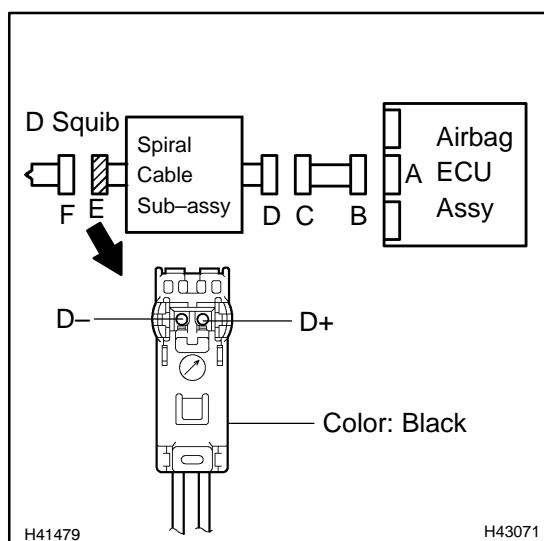

- Measure the resistance according to the value(s) in the table below.

Standard:

Tester connection	Condition	Specified condition
D+ – Body ground	Always	1 MΩ or Higher
D- – Body ground	Always	1 MΩ or Higher

NG
REPLACE SPIRAL CABLE SUB-ASSY (SEE PAGE 60-29)
OK

USE SIMULATION METHOD TO CHECK (SEE PAGE 60-29)

HINT:

- Perform the simulation method by selecting the check mode with the hand-held tester (see page 05-1405).
- After selecting the check mode, perform the simulation method by wiggling each connector of the airbag system or driving the vehicle on a city or rough road (see page 05-1405).