

EW10A

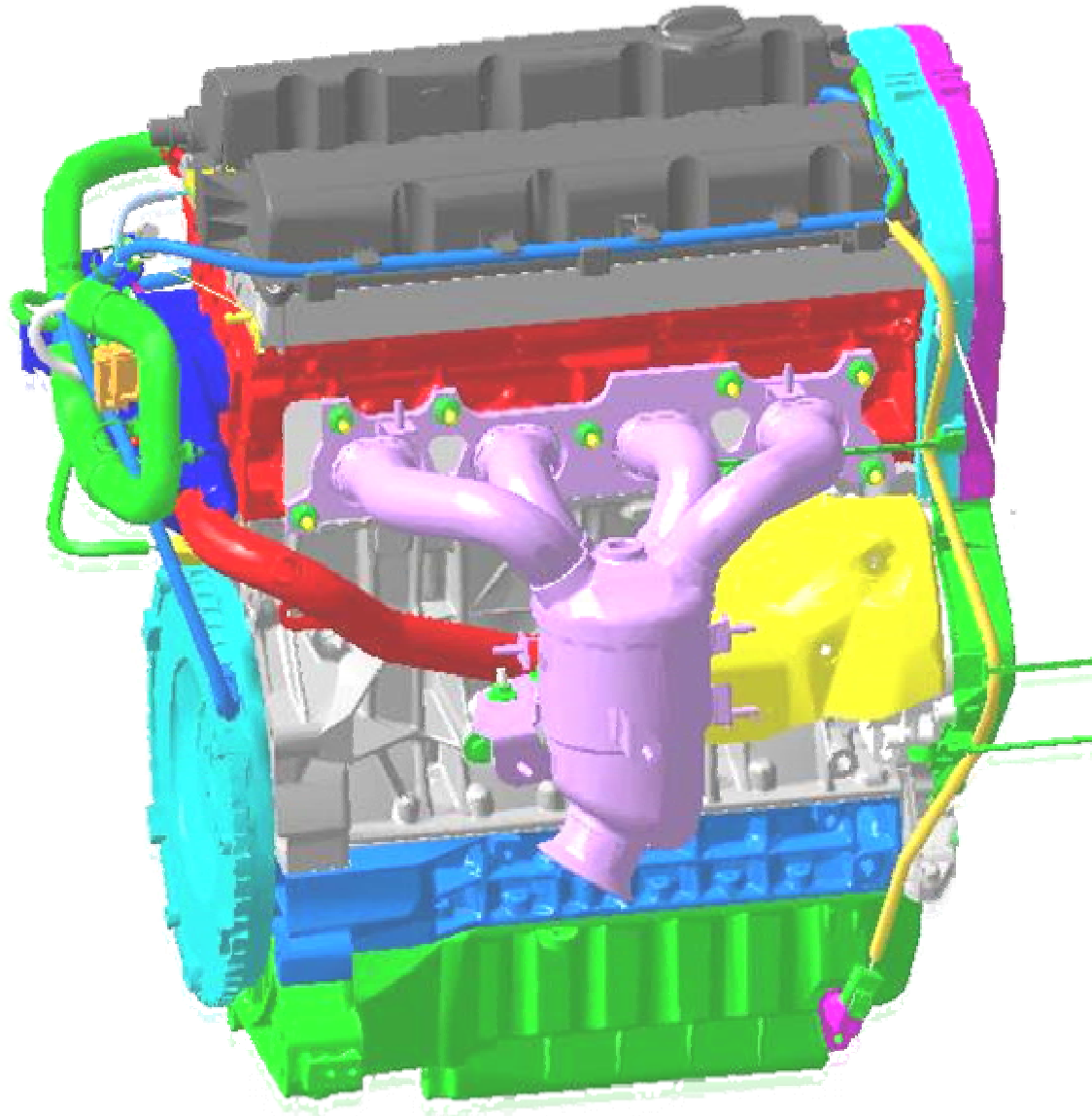

- 有一个有竞争力的**2**升发动机
- 减小燃油消耗 (大约 **5%**)
- 在低车速和中转速时提高扭矩
- 增加最大功率
- 符合欧**4**标准而且预先为欧**5**设计

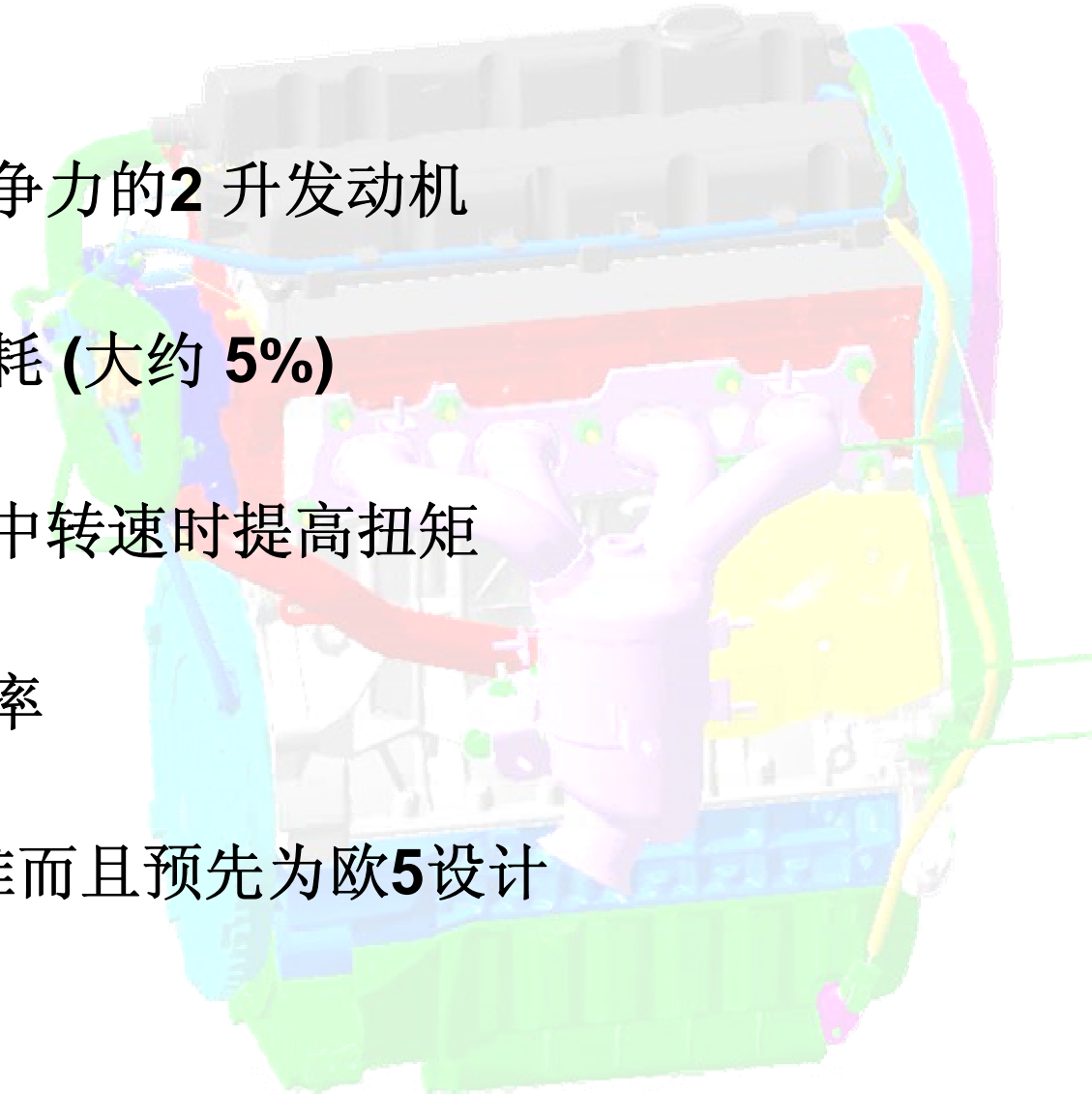

系统介绍

103 kW RFJ

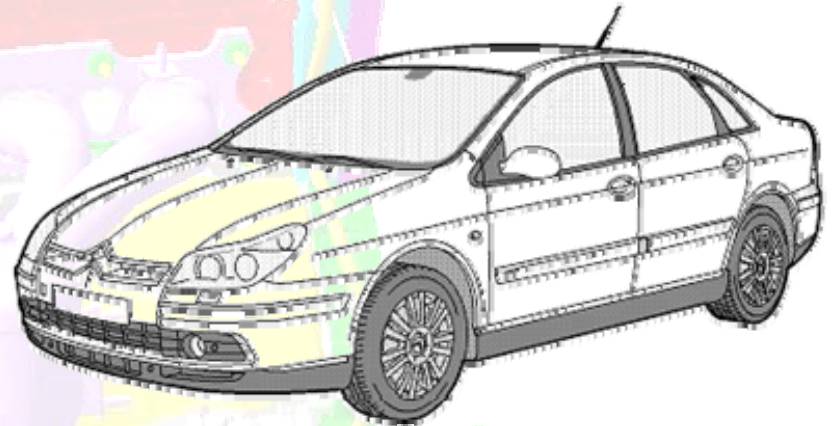
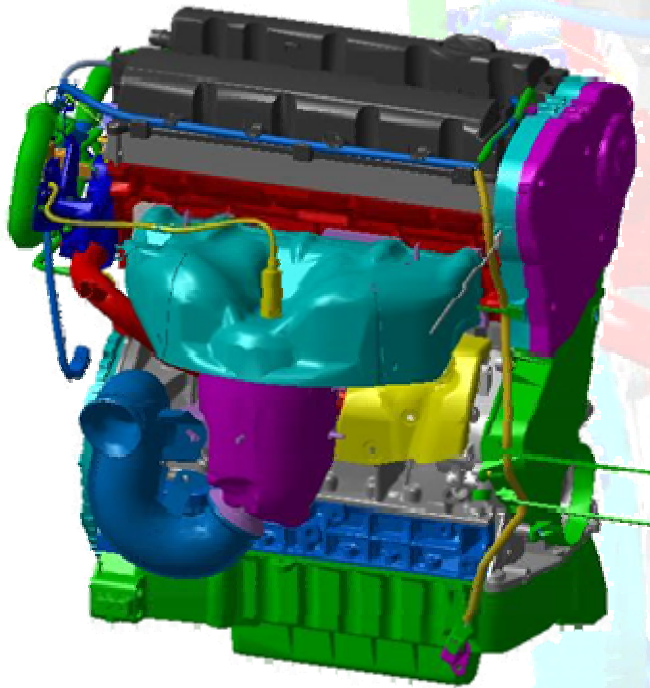

BVA AL4 .

系统介绍

EW10J4

EW10A

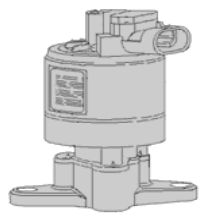

EGR 电磁阀

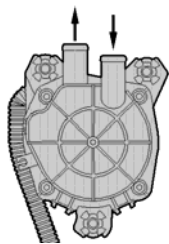
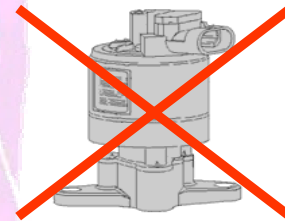

二次
空气泵

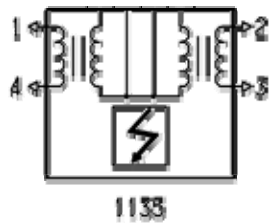
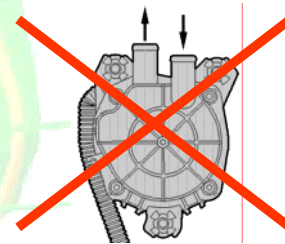

点火

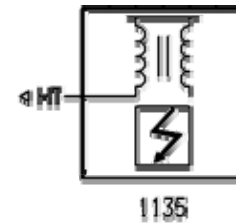

1133

1135

系统介绍

EW10A

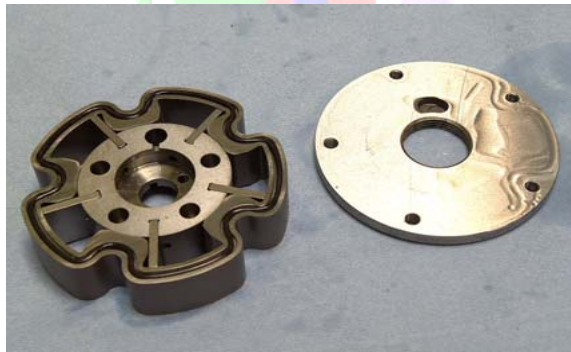

可变配气正时

喷射系统



发动机线束

单个发动机线束 (FMU)

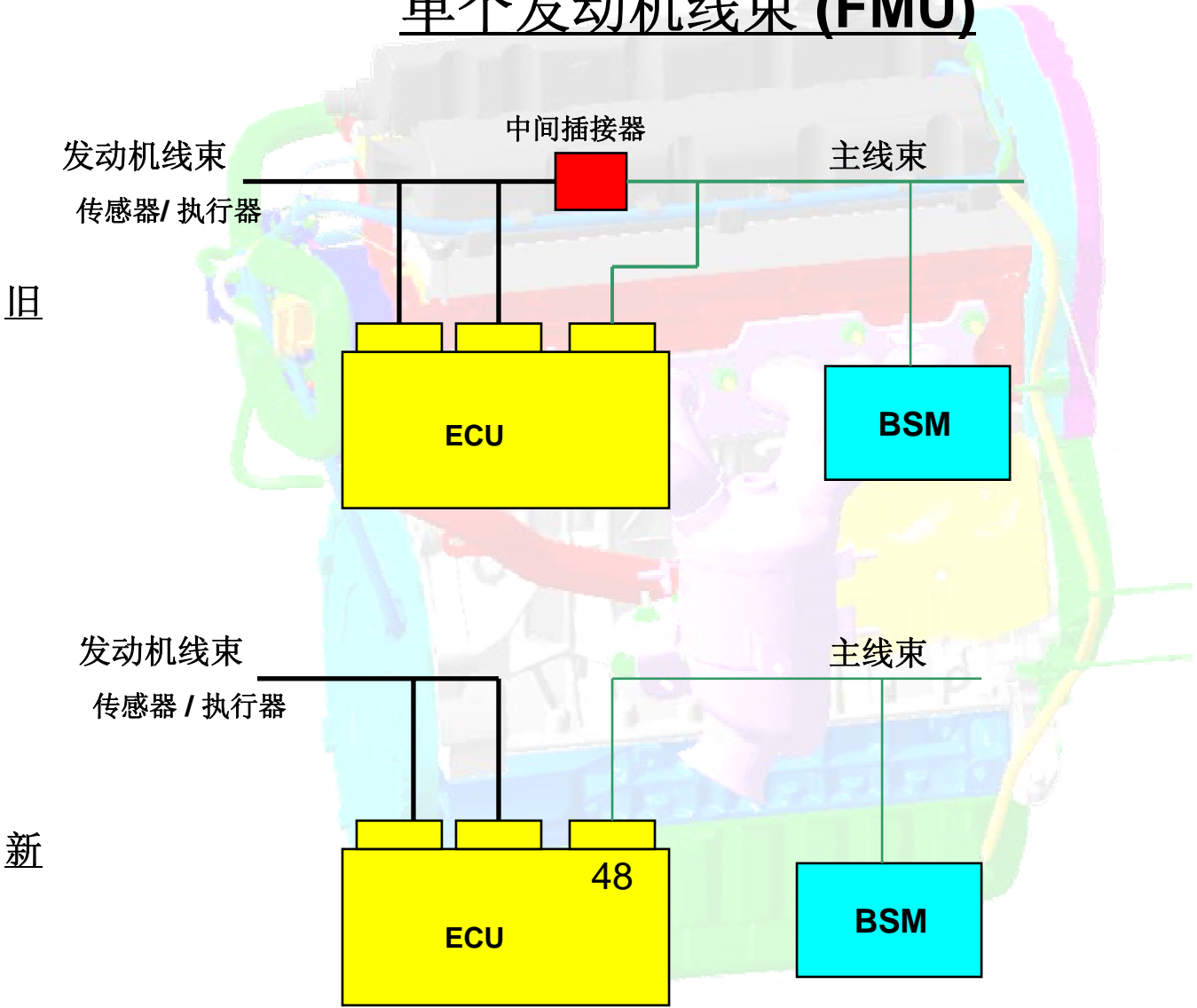

歧管下方的三元催化器

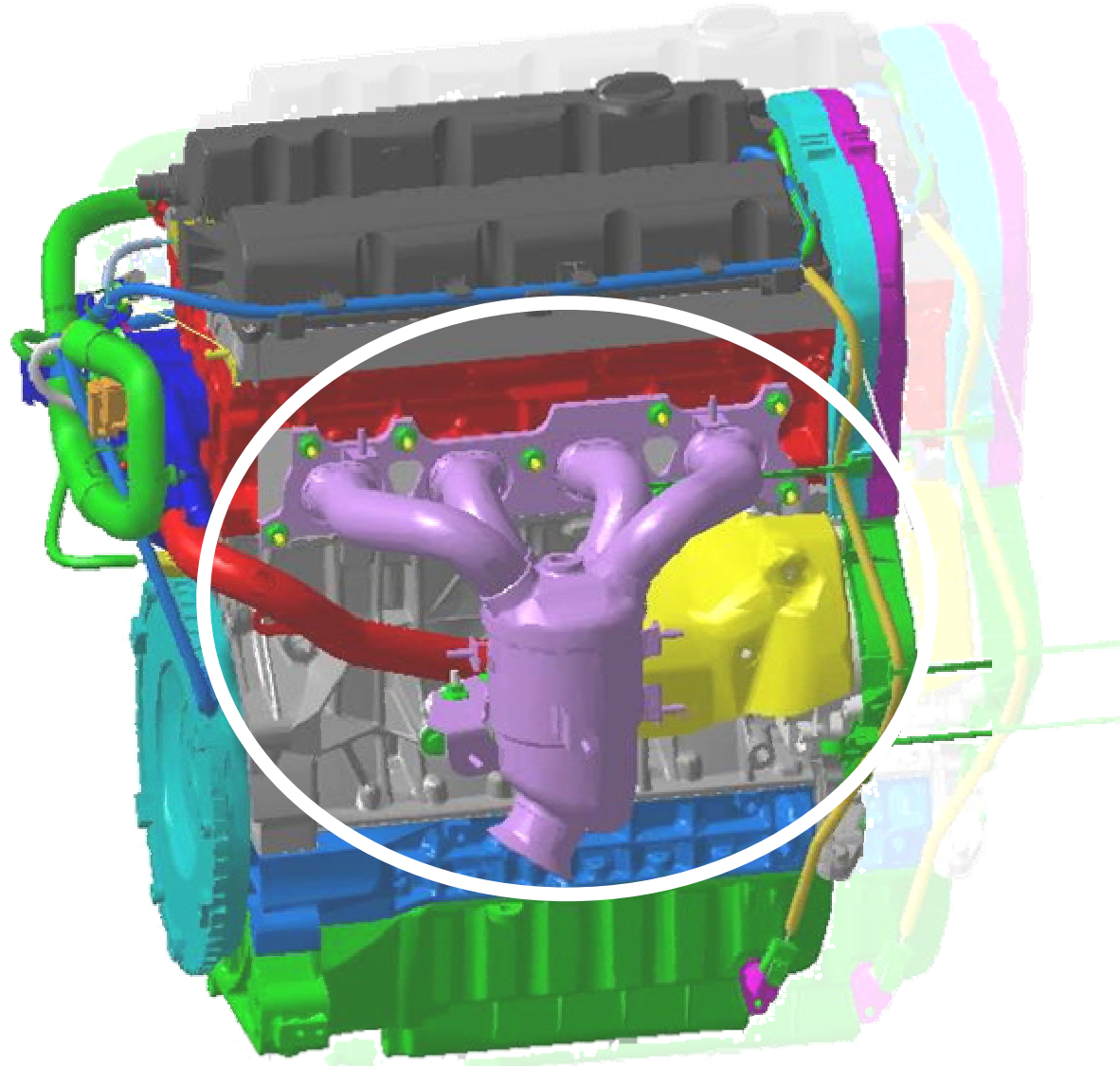

带热交换器的机滤

