

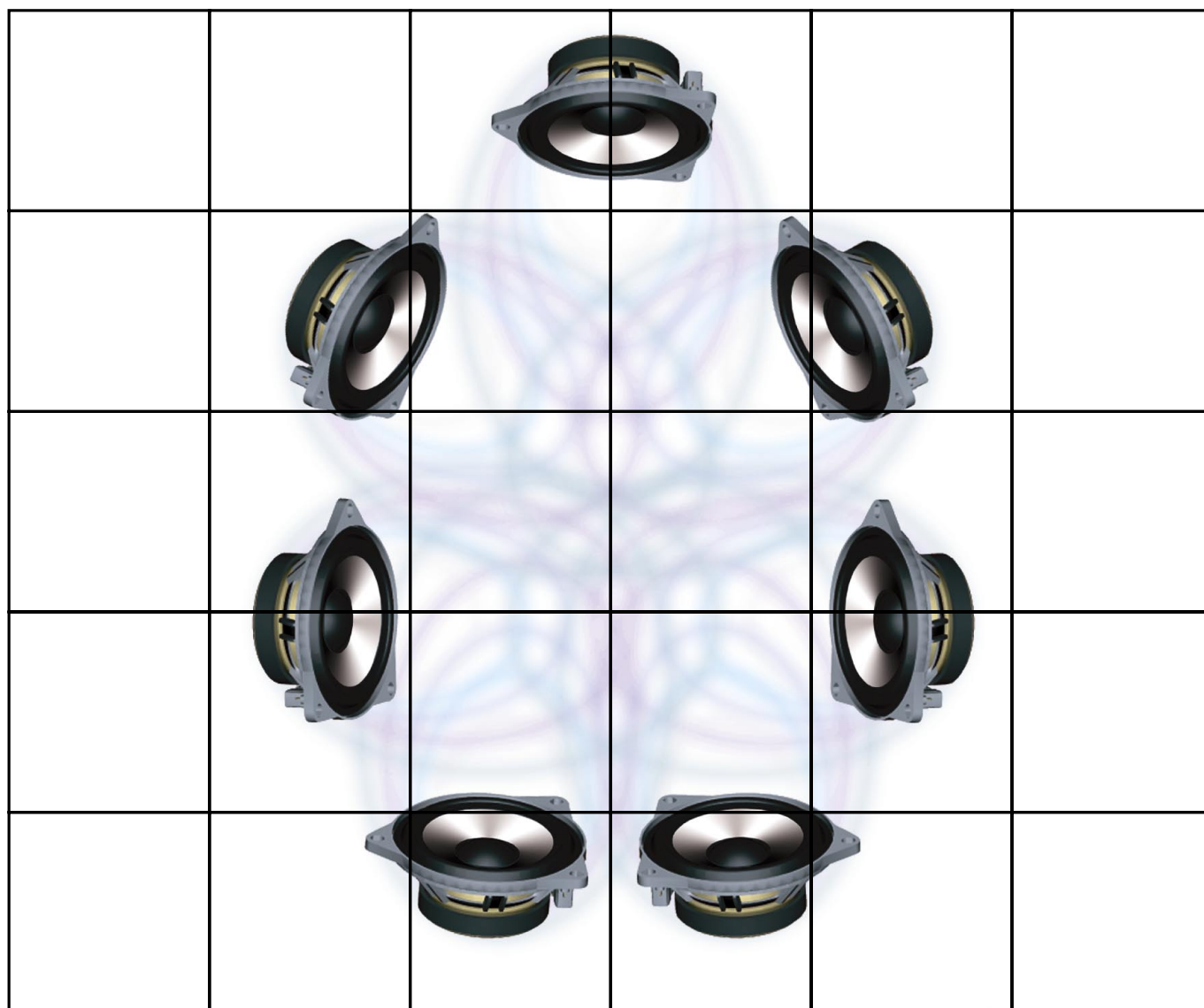

## **E63 Information and Communication** Participant Manual



**NOTE**

The information contained in this participant's manual is intended for participants of the Aftersales Training.  
Refer to the relevant "BMW Service" information for any changes/supplements to the Technical Data.

© 2003 BMW AG

München, Germany. Reprints of this manual or its parts  
require the written approval of BMW AG, München  
VS-12/VS-42 MFP-HGK-BRK-E63\_0900

## Contents

	<b>Page</b>
<b>CHAP 1 E63 Information/Communication Technology</b>	<b>1</b>
Introduction	1
System overviews	5
- Bus overview	5
- System circuit diagram	7
Car communication computer	9
- Introduction	9
- Advantages of the car communication computer	9
Hardware	10
- Variants	11
- CD-ROM / MD drive	14
- DVD drive	15
- HIP module	16
- Gyro sensor	17
- Tuner module	17
- Main board with processors	18
- Power board	19
- Audio board with DSP	20
- Memory module (main memory)	20
- Physical arrangement of the boards	21
- Front panel	21
Service concept for the car communication computer	22
Working on electronic components	23
System functions	25
- DVD navigation system, Professional	26
- Voice control system	28
- TV function	30
- Online services	35
E63/E64 Audio systems	36
- Introduction	36
- System overview HiFi E63/E64	37
- System overview Top-HiFi E63/E64	41
Telephone system	45
Universal mobile phone preparation	45
System overview	46
System circuit diagram	47
- Components	48
- Electronic universal charging and hands-free module ULF	48
- Eject box	53
- Bluetooth mobile phones	55
- GSM aerial	56

- Compensator	56
- Bluetooth aerial	56
- ULF system functions	57
- Telephoning	57
Telecommunication services	60
- Introduction	60
- General telephone function	61
- Telecommunication services without navigation system	62
- Telecommunication services US	63
- Telecommunication services with navigation system	64
- TeleService 1	65
- BMW ASSIST	69
- Online services	76



## E63 Information/Communication Technology

### Introduction

The 6 Series Coupe E63 is the successful continuation of the legendary BMW Coupes. The new design line, originating with the 7 Series, has been consistently adopted in the styling.



KT-12070

03508\_03

Fig. 1: 6 Series Coupe E63

The technology in the area of the electric/electronic systems in the E63 is based on that of the E60. Depending on the options configuration, the E63 offers the following information and communication systems:

- Car communication computer
- 8.8" central information display with split screen
- High controller with simplified operation
- Head-up display
- Navigation system, Professional
- Top-HiFi amplifier with LOGIC7
- New telephone system with GSM dualband and telematics
- Universal charging and hands-free facility for Bluetooth mobile phones
- Voice control system

## Car communication computer

The car communication computer is the central control unit for the information and communication systems in the E63. The car communication computer comprises the functions of the M-ASK as well as the following functions:

- Voice control system for voice command of all systems
- Navigation system Professional with map presentation
- TV function on CID
- Access to Internet-based services



KT-11532

Fig. 2: Car communication computer

02892 02

## Controller

The controller is the central control/operating element for all comfort and car functions. The shift directions have been reduced to four.

The feedback haptics is produced electrically in connection with the controller in the E63.



KT-11407

02763\_02

Fig. 3: E60 controller with additional control buttons (High equipment)

## Head-up display

BMW offers a head-up display with the introduction of the E63. Here additional information is beamed into the driver's field of vision. The driver can read this information without having to take his/her eyes off the road ahead, This is a significant feature enhancing overall safety.

### **Navigation system**

The E63 is equipped with the navigation system Professional with map presentation in the central information display. The E63 no longer features a separate navigation computer. The navigation system has been integrated in the car communication computer.

### **Top-HiFi amplifier with LOGIC7**

The E63 offers a choice of two different audio systems. The HiFi audio system is fitted as standard. The Top-HiFi system is optionally available. In the Top-HiFi version, the amplifier has a LOGIC7 function, i.e. there is optimum spatial sound.

### **New telephone systems**

The E63 is equipped with the new fixed installation telephone system based on the Everest platform. It features a dualband GSM telephone and various telematics functions.

The E63 is also equipped with a universal charging and hands-free facility, making it possible for the customer to incorporate a Bluetooth mobile phone in the communication network of the E63.

### **Voice control system**

The car communication computer will be combined with a voice input system, which can be used to execute most of the functions by way of voice commands in the communications network.

# System overviews

## - Bus overview

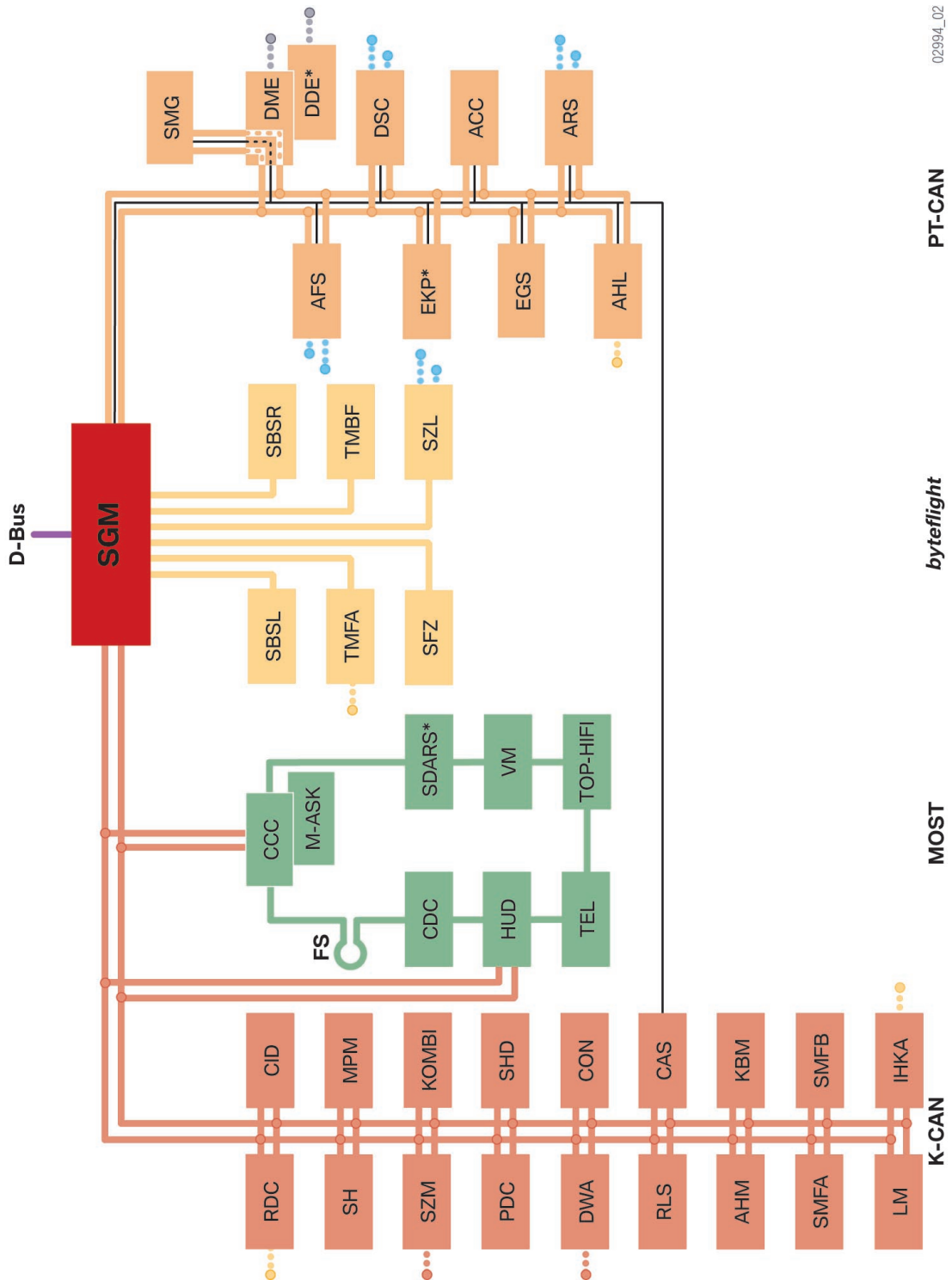

02994\_02

PT-CAN

byteflight

MOST

K-CAN

KT-11713

Fig. 4: Bus overview E63

## E63 Information and Communication

<b>Index</b>	<b>Explanation</b>	<b>Index</b>	<b>Explanation</b>
RDC	Tyre pressure control	HUD	Head-up display
SH	Independent heating	TEL	Telephone
SZM	Centre console switch cluster	TOP-HIFI	Top-HiFi amplifier
PDC	Park distance control	VM	Video module
DWA	Antitheft alarm system	SDARS*	Satellite digital audio radio services (US only)
RLS	Rain/low beam sensor	SGM	Safety and gateway module
AHM	Trailer module	SBSL	B-pillar satellite, left
SMFA	Driver's seat module	TMFA	Driver's door module
LM	Light module	SFZ	Vehicle centre satellite
IHKA	Automatic climate control	SZL	Steering column switch cluster
SMBF	Passenger's seat module	TMBF	Passenger door module
KBM	Basic body module	SBSR	B-pillar satellite, right
CAS	Car access system	AFS	Active steering
CON	Controller	EKP	Electric fuel pump control
SHD	Slide/tilt sunroof	EGS	Electronic transmission control
KOMBI	Instrument cluster	AHL	Adaptive headlight
MPM	Micro power module	ARS	DynamicDrive
CID	Central information display	ACC	Active cruise control
CCC	Car communication computer	DSC	Dynamic stability control
M-ASK	Multi-audio system controller	DME	Digital motor electronics
FS	Flash connector	DDE	Digital diesel electronics
CDC	CD changer	SMG	Sequential manual gearbox



- System circuit diagram

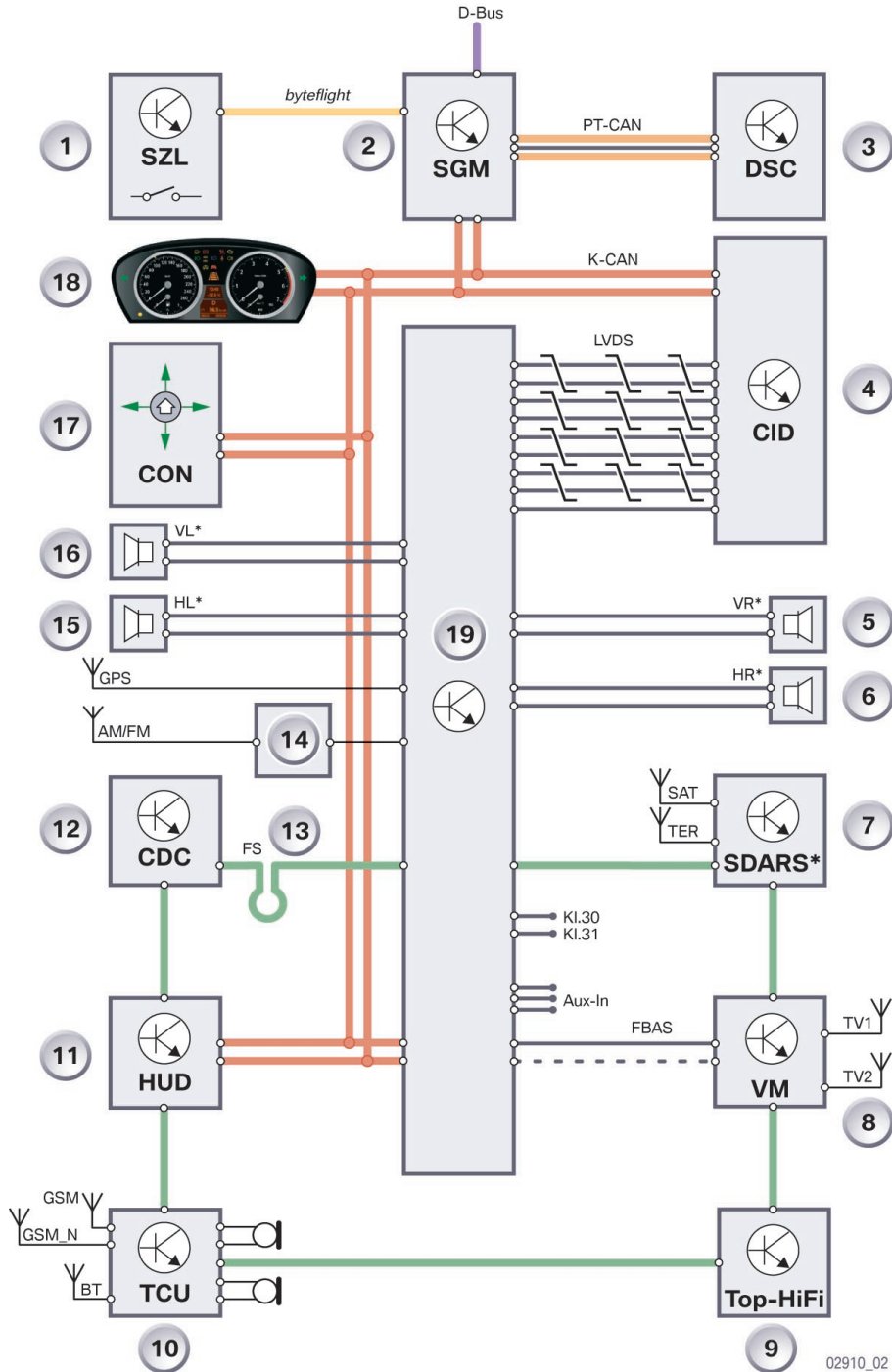

KT-11556

02910\_02

Fig. 5: System circuit diagram of car communication computer

## E63 Information and Communication

Index	Explanation
1	Steering column switch cluster with buttons for volume and station selection
2	Safety and gateway module
3	DSC control unit
4	Central information display
5	Speaker, front right (only if no Top-HiFi amplifier is installed)
6	Speaker, rear right (only if no Top-HiFi amplifier is installed)
7	Satellite radio receiver (option)
8	Video module (option)
9	Top-HiFi amplifier (option)
10	Telematics control unit (option)
11	Head-up display
12	CD changer (option)
13	Flash connector
14	Aerial diversity
15	Speaker, rear left (only if no Top-HiFi amplifier is installed)
16	Speaker, front left (only if no Top-HiFi amplifier is installed)
17	Controller
18	Instrument cluster for check control messages
19	Car communication computer
GPS	GPS aerial for navigation
AM/FM	Radio aerials
GSM	Telephone aerial
GSM_N	Telephone emergency call aerial
BT	Bluetooth aerial
SAT	Satellite aerial
TER	Terrestrial aerial
TV1	TV aerial 1
TV2	TV aerial 2
LVDS	Low voltage differential signal (digital RGB cable)
FBAS	Video signal cable from video module to car communication computer
KI.30	Terminal 30, power supply
KL.31	Terminal 31, ground



## **Car communication computer**

### **- Introduction**

In principle, the structure of the car communication computer corresponds to that of a personal computer. In the same way as a personal computer, the car communication computer contains a processor as well as RAM modules and other peripheral components. Certain functions such as the voice input control system are integrated in the form of software in the car communication computer.

The car communication computer is the central control module for all applications. It is always coupled with the 8.8" split-screen central information display. The car communication computer also features the high variant of the controller with haptic feedback.

The car communication computer is based on a modular design, i.e. the main systems of the communication network are integrated in the form of modules in the car communication computer. It can be configured and expanded corresponding to requirements. At the time of market launch, the following modules/functions will be integrated in the car communication computer:

- Radio double tuner
- DVD navigation system, Professional (map presentation)
- Voice control system
- ASK functions
- MOST-CAN gateway functions

### **- Advantages of the car communication computer**

The following advantages are achieved by combining several control units in one module:

- Increased functionality by combining several systems
- Easy to expand/upgrade by means of software with corresponding interfaces
- Fewer plug connections therefore fewer potential fault sources
- Reduced package space for control units

## Hardware

The car communication computer consists of several components: Based on the planned service concept, in future, it will be possible to individually replace most parts. These components are identified in the following table:

<b>Component</b>	<b>Replacement planned in service concept</b>
Housing	No
CD-ROM drive	Yes
MD drive	Yes
DVD drive	Yes
HIP-module (host independence positioning module)	Yes
Gyro sensor	Yes
Tuner module	Yes
Main board	No
Power board	No
Audio board	Yes
Memory module	Yes
Front panel	Yes
Front panel with Bluetooth module (not at SOP)	Yes
PMC-card 1 for rear compartment entertainment (not at SOP)	Yes
PMC-card 2 open	Yes
PCMCIA-card for memory expansion (not at SOP)	Yes
Electric fan	Yes

After replacement, corresponding programming or encoding may be necessary depending on the component.

## - Variants

Two variants of the car communication computer will be available:

- CD-ROM and DVD drive (worldwide, excluding Japan)
- MD and DVD drive (Japan only)

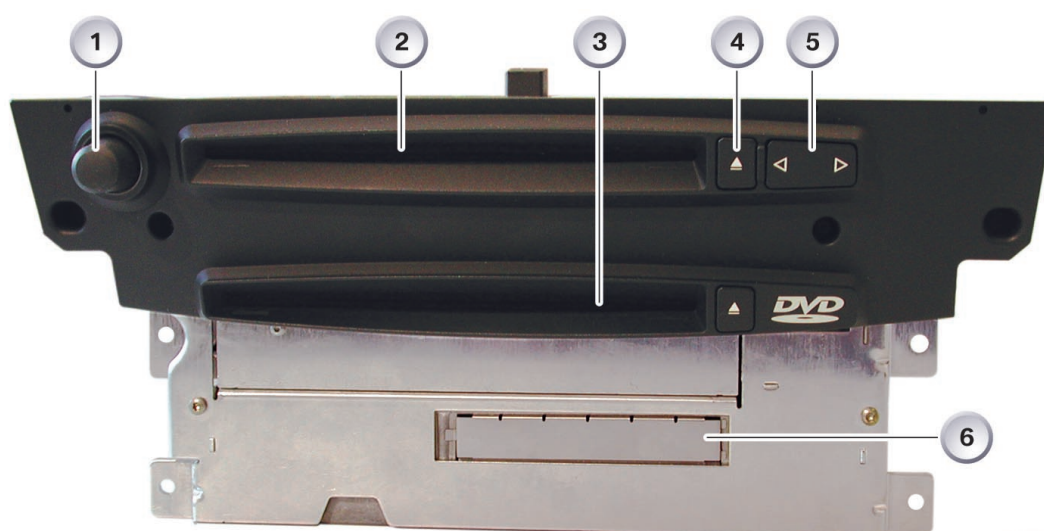

KT-11743

02999\_02

Fig. 6: Car communication computer

Index	Description
1	ON/OFF rotary push-button for volume control of audio system
2	CD drive drawer
3	DVD drive drawer
4	Eject button 2 x CD and DVD
5	Search button
6	Cover for future memory expansion

In the Japan version, the navigation system is not included in the car communication computer. In view of the large quantities of data required for 3D navigation, the navigation system is incorporated in a separate navigation computer.

**Connector views**

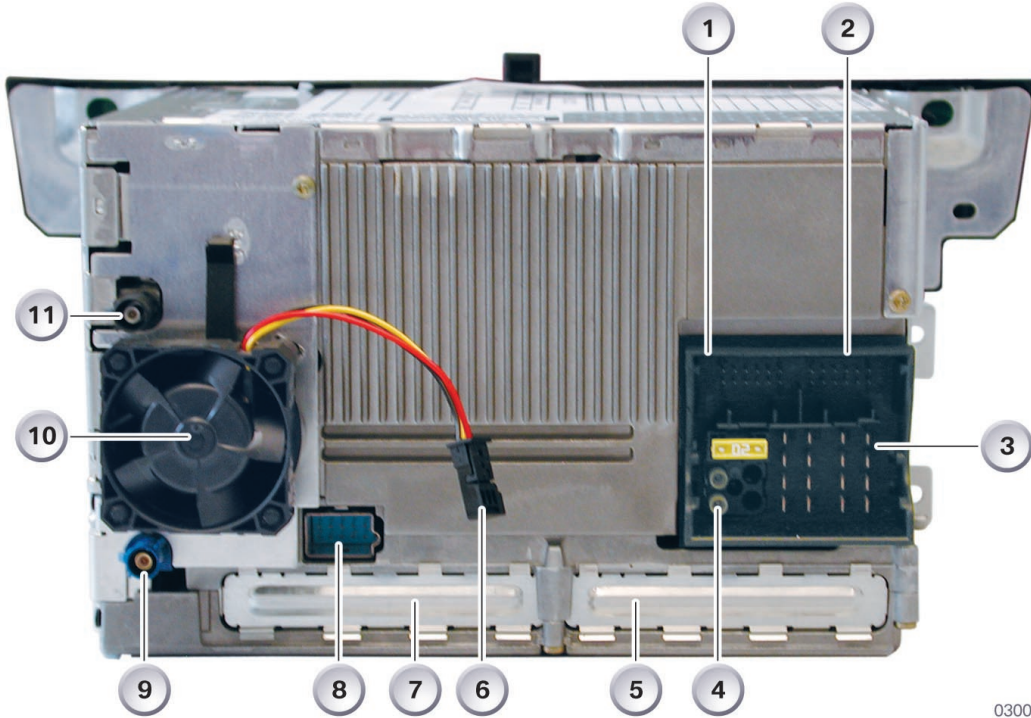

KT-11744

03000\_02

Fig. 7: Rear view of car communication computer

Index	Description
1	12-pin connector, left
2	12-pin connector, right
3	16-pin connector
4	MOST connector
5	Cover for expansion card
6	Connection for fan motor
7	Cover for expansion card
8	LVDS connector
9	GPS aerial connector
10	Fan motor
11	Radio aerial connector

## Design

The car communication computer is accommodated in an aluminium casing. The size of the car communication computer corresponds to two radio DIN casings.

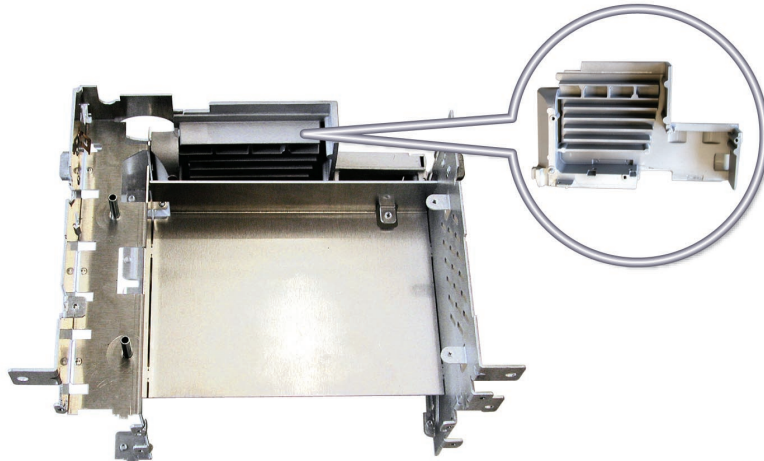

KT-11753

03031\_02

Fig. 8: Car communication computer casing with air ducts

The main board is housed in a pressure diecast aluminium casing. The two-piece casing consists of a base plate and the cover.

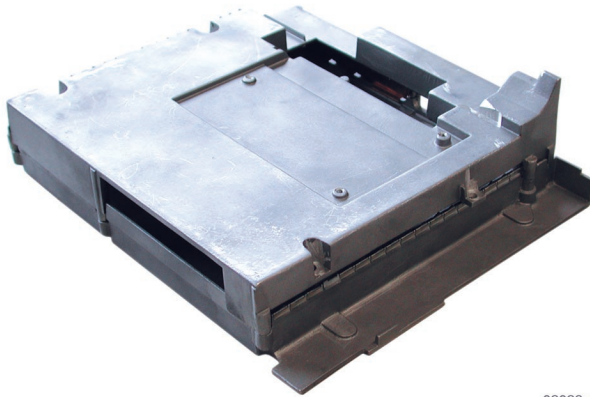

KT-11766

03038\_02

Fig. 9: Aluminium casing for main board

**Note:** In view of the large number of processors, particular importance is attached to electromagnetic compatibility (EMC). All processors feature metal covers to ensure they do not mutually influence each other and emit no radiation. EMC measures are particularly important for the tuner. For these reasons, it is of the utmost importance to ensure that the covers and panel parts are positioned correctly when assembling the casing.

**- CD-ROM / MD drive**

The car communication computer is equipped worldwide with a CD-ROM drive. The following types of CD can be played on the CD-ROM drive:

- Audio CD
- Audio CD-ROM with MP3 files

The MP3 files are decoded in the DSP of the audio board.

Only in the Japan version is the car communication computer equipped with an MD drive (**M**ini-**D**isk) instead of a CD-ROM drive.

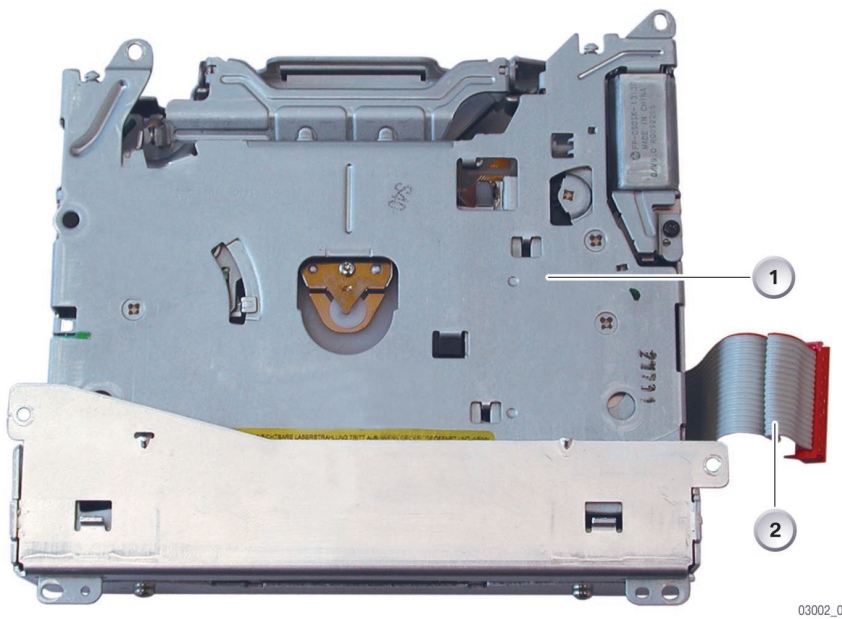

03002\_02

KT-11746

Fig. 10: CD drive

Index	Description
1	CD drive
2	CD drive connection to audio board



## - DVD drive

All car communication computers feature a second drive, a DVD drive that plays the navigation DVD. The DVD contains the entire navigation data for Europe or the USA.

The navigation DVD remains in the drive during navigation. In view of the high data volume for map presentation, the data are read directly from the DVD.

When the navigation system is not in use, the DVD drive can also be used to play audio CDs or audio CD-ROMs with MP3 files.

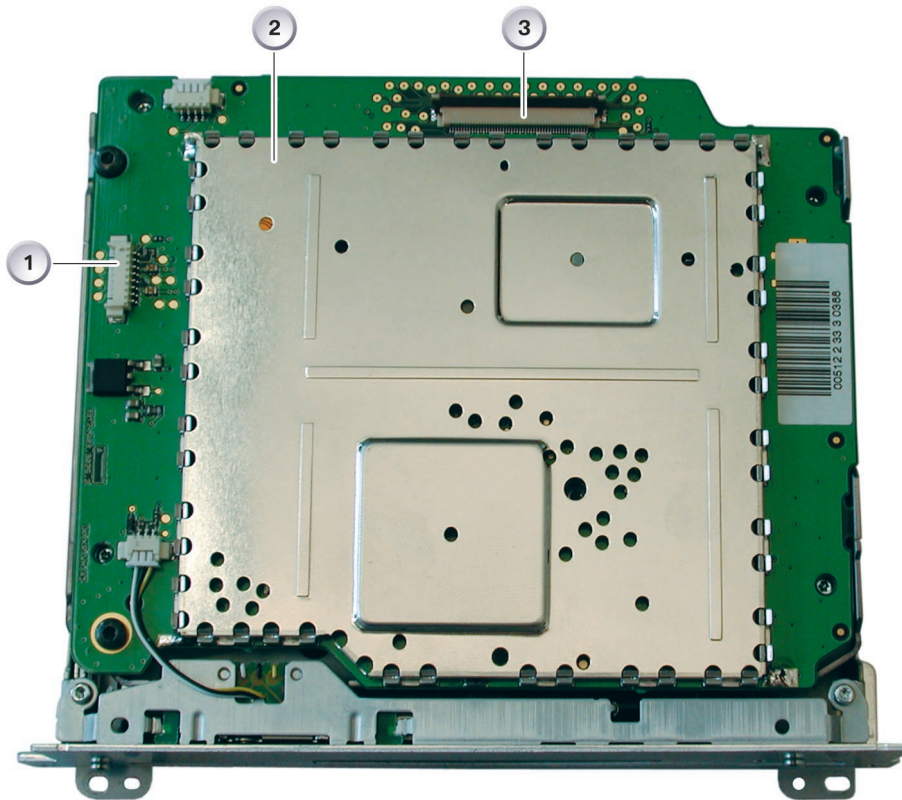

KT-11747

03003\_02

Fig. 11: DVD drive

Index	Description
1	DVD drive connector
2	DVD drive
3	Ribbon cable connection to DVD drive

## - HIP module

The HIP module (**H**ost **I**ndependence **P**ositioning) is integrated in the car communication computer. The HIP module contains the GPS receiver that has the task of converting and decoding the signals received from the GPS aerial.:

Furthermore, telegrams containing speed information from the wheel speed sensors are received from the DSC control unit via the K-CAN.



KT-11751

Fig. 12: HIP module

03007\_02

## Functional principle

The data supplied by the satellites and the DSC control unit are processed in the HIP module and the following information is derived:

- Longitude
- Latitude
- Altitude above sea level
- Direction
- Speed

The information from the gyro sensor is also included in the calculation of the navigation data.

These data are transferred to the navigation system. The almanac data must be stored (e.g. during ignition off) as it takes a long time to download them from the satellites. This procedure ensures that after a new start the location of the vehicle is known and navigation can start immediately.



### - Gyro sensor

A gyro sensor is integrated in the car communication computer. The gyro sensor is a separate module that is connected via plug contacts to the main board and is secured by a screw. The gyro sensor supplies the change in heading data. The data are required for determining the location exactly as satellite signals cannot be received everywhere.

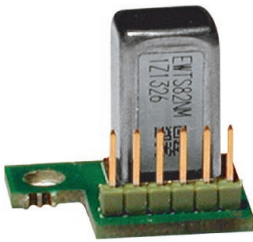

KT-11763

Fig. 13: Gyro sensor

### - Tuner module

The tuner module in the car communication computer is a separate unit. The tuner module consists of two tuners, referred to as tuner1 and tuner2 in the following. The tuners are world tuners, i.e. they can be coded for the entire frequency band. The tuner functions correspond to the M-ASK.

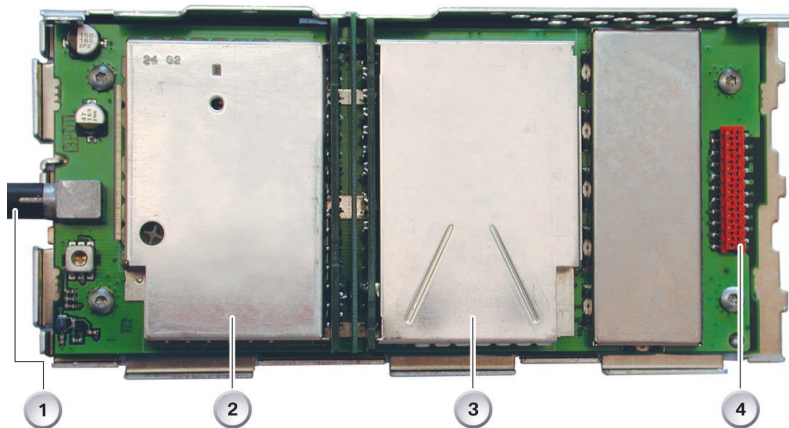

KT-11767

03001\_02

Fig. 14: Tuner module

Index	Description	Index	Description
1	Connection for radio aerial	3	Tuner2 (data tuner)
2	Tuner1 (audio tuner)	4	Plug connection to audio board

**- Main board with processors**

In addition to the CPU (Central Processing Unit) further processors and main memories are mounted on the main board. The main board also contains plug-in slots for expansion boards.

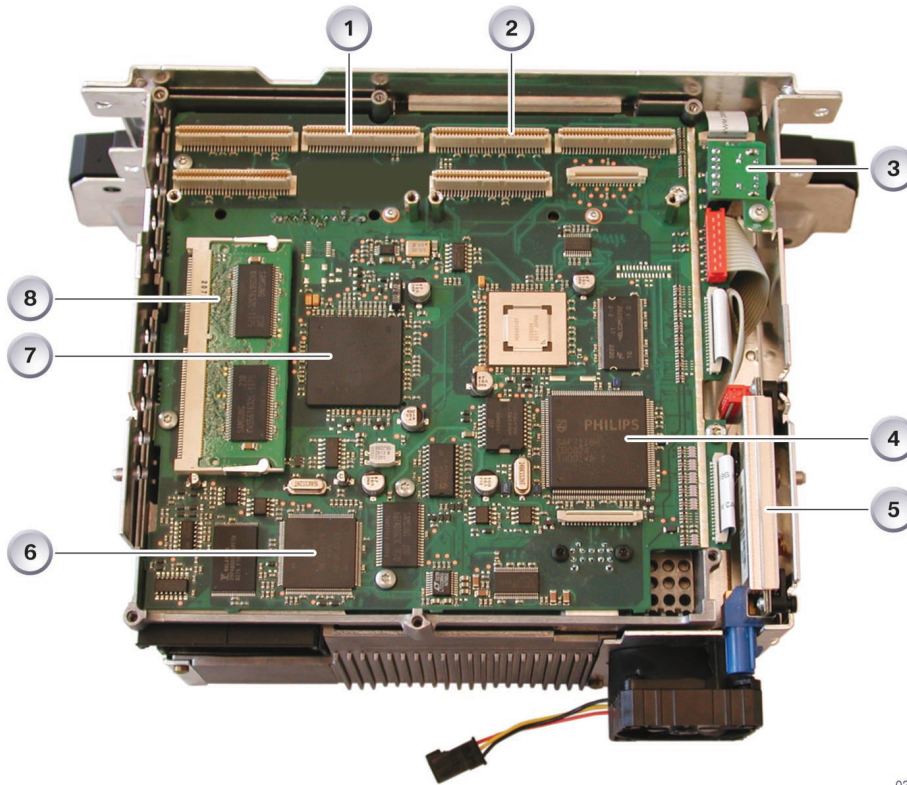

KT-11750

03006\_02

Fig. 15: Main board of car communication computer

Index	Description	Index	Description
1	Plug-in contacts for PMC card 1	5	HIP module
2	Plug-in contacts for PMC card 2	6	Gateway processor
3	Gyro sensor	7	CPU (200 MHz)
4	Graphic processor	8	Memory module

**Note:** Together with the power board and casing, the main board forms the basic module. Only the car communication computer can be replaced completely in the event of a defect in the basic module.

**- Power board**

The power board is located at the rear of the car communication computer. The FAKRA main connector for the power supply and the MOST connector are secured on the power board. The main connector provides the interface to the vehicle electrical system.

The power board provides the power supply for all boards and modules. The four audio output stages for the speakers are located on the power board.

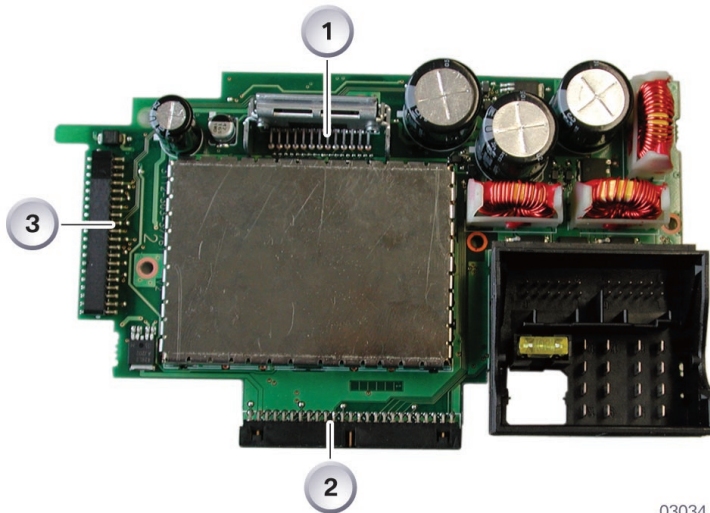

KT-11765

03034\_02

Fig. 16: Power board

Index	Description
1	Audio output stages
2	Plug contact to main board
3	Plug contact to audio board

**Note:** Together with the power board and casing, the main board forms the basic module. The car communication computer must be replaced completely in the event of a defect in the basic module.

### - Audio board with DSP

The audio board is located on the right-hand side of the car communication computer. The audio board is connected by means of plug contacts to the main board. The tuner module is also connected to the audio board via plug contacts.

The ASK functions are located on the audio board. Two digital sound processors facilitate simultaneous conditioning of the audio signals and operation of the voice control system.

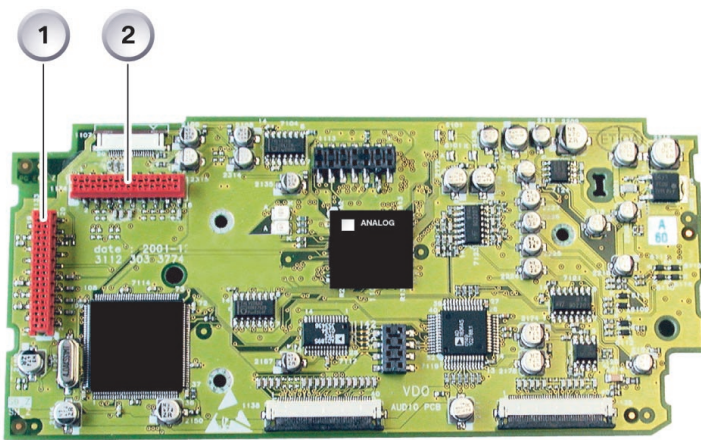

KT-11758

03036\_02

Fig. 17: Audio board

Index	Description	Index	Description
1	Plug contacts for tuner module	2	Plug contacts for CD drive

### - Memory module (main memory)

The memory module is located on the main board and is connected via plug contacts. The memory module is designed such as to provide sufficient main memory RAM and flash memory for all current applications.

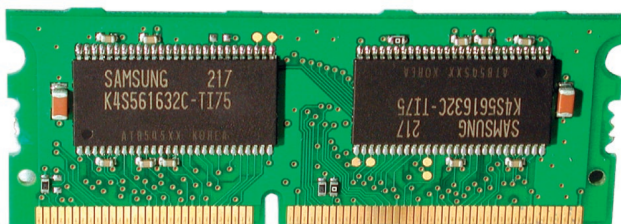

KT-11815

03076\_03

Fig. 18: Card for memory module



**- Physical arrangement of the boards**

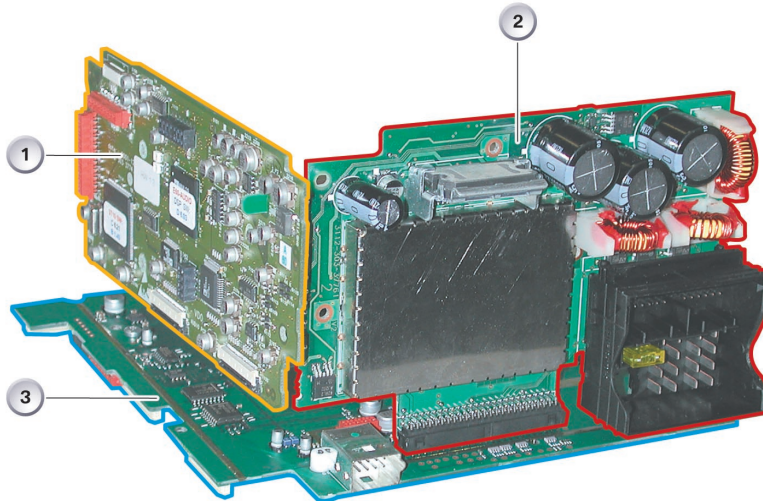

KT-11755

03033\_02

Fig. 19: Arrangement of the boards in the car communication computer

Index	Description	Index	Description
1	Audio board	3	Main board
2	Power board		

**- Front panel**

The front panel is the only visible part of the car communication computer. It consists of slots for the CDs and DVDs as well as the control knobs.



KT-11759

03037\_02

Fig. 20: Rear view of front panel with Bluetooth module

Index	Description	Index	Description
1	Bluetooth module	2	Connection

## **Service concept for the car communication computer**

The service concept is such that individual modules and parts of the car communication computer can be replaced in the event of malfunction, thus serving to reduce repair costs. A differentiation is made between electronic and mechanical parts.

### **Electronic parts**

Replacement of the following electronic parts is planned:

- CD/MD drive
- DVD drive
- Tuner module
- HIP module
- Gyro sensor
- Front panel
- Front panel with Bluetooth module (not at SOP)
- Audio board
- Memory module
- PMC cards
- Electric fan

### **Mechanical parts**

Following mechanical parts are available:

- Top cover
- Bottom cover
- DVD drive retaining fixture
- CD/MD drive retaining fixture
- DVD drive holder
- CD/MD drive holder
- Cover for PMC slot
- Cover for PCMCIA slot
- Rubber mount for electric fan

Particular attention must be paid to electrostatic discharge ESD when working on the car communication computer. Disregard of the safety requirements may result in damage to the electronic components in the car communication computer.



KT-11917

Fig. 21: ESD warning symbol

## Working on electronic components

### Preparatory work

The following points must be observed when working on electronic components of the car communication computer corresponding to the service concept.

All work must be carried out on a conductive and earthed workbench. The special tool 12 7 192 is additionally used for this purpose.

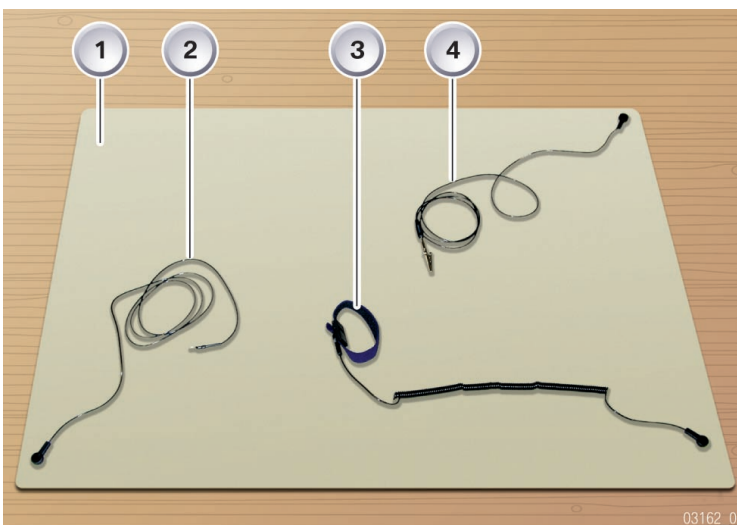

KT-11915

Fig. 22: Special tool 12 7 192

Index	Description
1	Antistatic mat
2	Earthing cable for antistatic mat
3	Wrist cuff
4	Earthing cable for component

The earthing cable must be connected to a secure and reliable earthing point (water pipe, heating pipe, socket outlet earth). Before taking the parts out of their packaging, the person working on the components must first put on the wrist cuff in order to discharge himself. The electronic components are placed on the antistatic mat and also connected with the earthing cable.

### Replacement

The electronic components must be replaced as described in the repair instructions and following the procedure described on SIP Electrostatic Fundamentals, while observing ESD safety measures.



KT-11911

Fig. 23: Working only while wearing wrist cuff



## **System functions**

The car communication computer comprises the following functions:

- Radio
- DVD navigation, Professional (map presentation)
- Voice control system
- TV function
- Online platform
- Audio management
- ASK functions
- Driver for central information display
- MOST CAN gateway

The following functions are described in the next chapter:

- Navigation system, Professional
- Voice control system
- TV function
- Online platform

The following functions are identical to those of the M-ASK and have already been described in detail in the participant's manual E60 Information/Communication.

- Radio
- Audio management
- ASK functions
- Driver for central information display
- MOST CAN gateway

### **- DVD navigation system, Professional**

The DVD navigation system Professional is integrated in the car communication computer, i.e. there is no longer a separate navigation computer. The DVD navigation system Professional features the familiar map presentation configuration. The car communication computer is always coupled with the 8.8" central information display for the purpose of displaying the maps.

The following hardware components were integrated in the car communication computer for the purpose of realizing the functions of the navigation system Professional:

- DVD drive for navigation data
- HIP module for satellite signals
- Gyro sensor for exact location acquisition

### **System integration**

The navigation system is loaded in the form of software in the car communication computer. The navigation system uses the memories and processors in the car communication computer. The system has its own diagnosis address. The navigation system Professional is controlled via the controller and the menu buttons in the central information display.

These components were already described in the previous chapter Hardware.

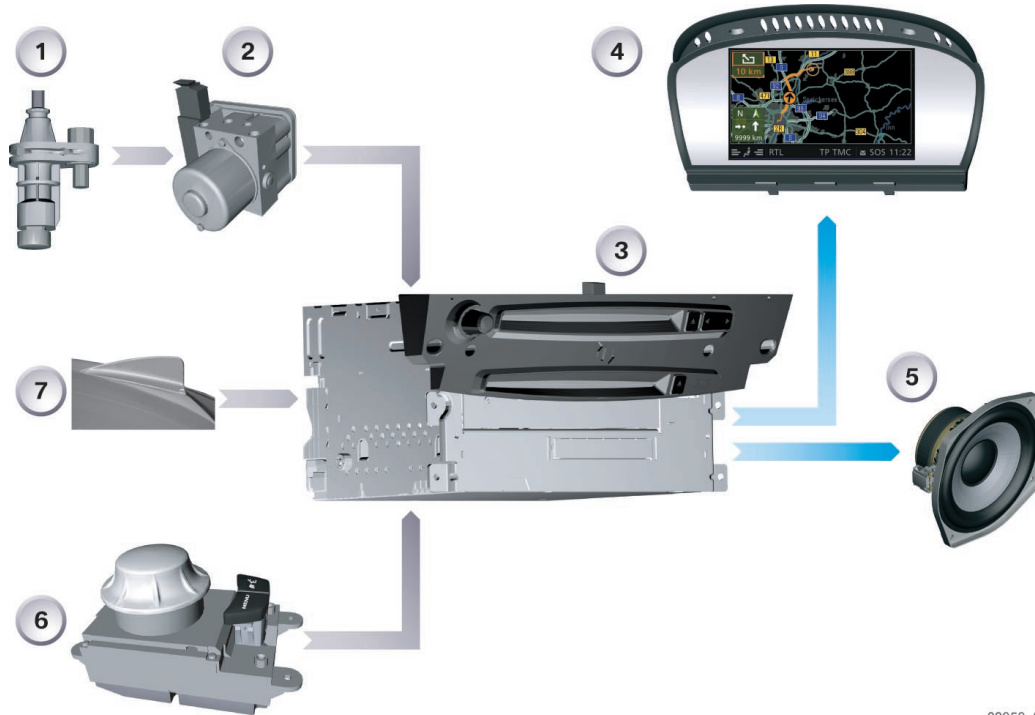

KT-11729

02959\_02

Fig. 24: Function diagram of the navigation system Professional

Index	Explanation
1	Wheel speed sensor
2	DSC control unit
3	Car communication computer
4	Central information display
5	Audio output
6	Controller
7	GPS roof aerial

## **- Voice control system**

A voice control system High is integrated in the car communication computer. With this system, all functions shown in the CID can be controlled by voice commands. This system has the advantage that the hands need not be taken off the steering wheel while driving in order to change settings. The SES can be used to control the following systems:

- Entertainment
- Communication
- Navigation
- Climate
- "5th Menu" setting

The voice control system makes use of specific voice commands. The voice control system sets up a dialogue with the user. Repeat requests are issued if the system did not understand a command.

## **System integration**

The voice control system is loaded as pure software in the car communication computer. The voice control system makes use of the memories and processors in the car communication computers as well as the hardware of other systems (e.g. microphones).

The two hands-free microphones in the front roof console are used in connection with the voice control system. The hands-free microphones are connected directly to the telematics control unit (TCU). The TCU sends the microphone signals via MOST to the car communication computer where they are processed in the DSP in order to execute the required functions.

If no telephone system is installed, only one hands-free microphone will be connected directly to the car communication computer.

Functional principle of voice control system

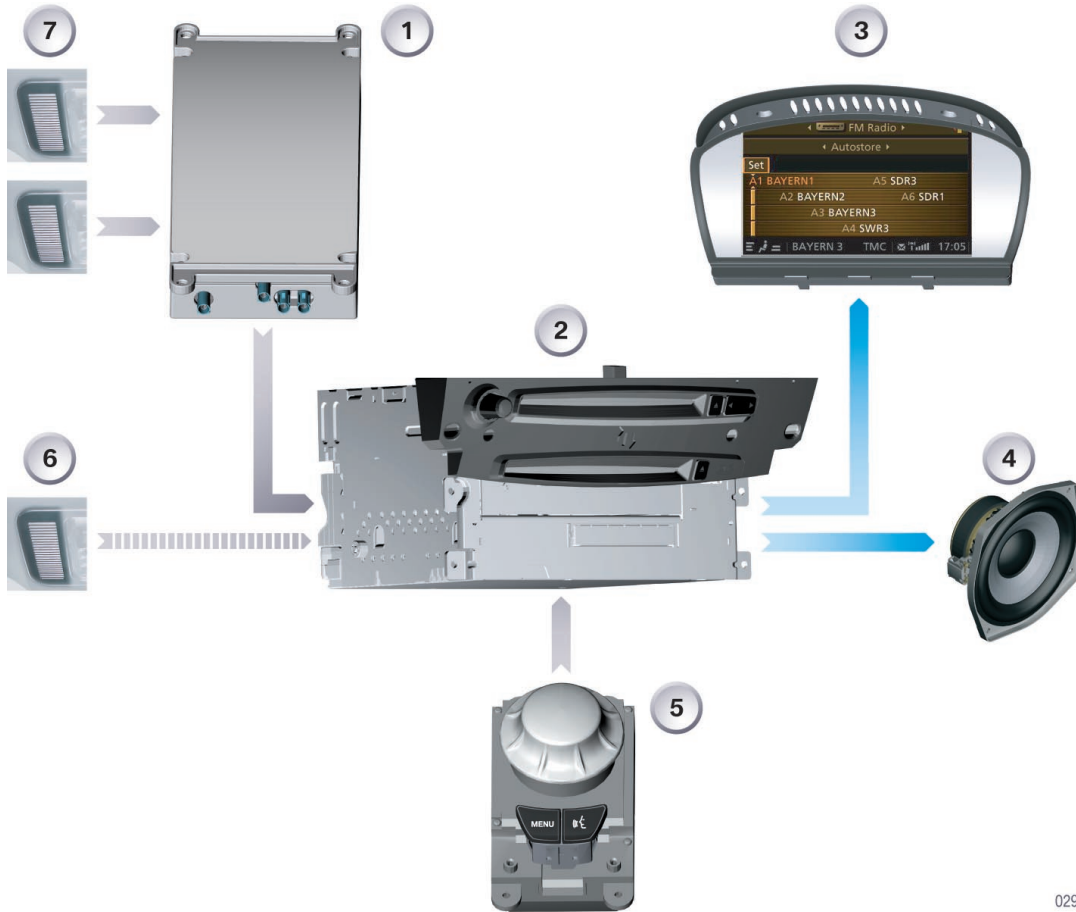

KT-11730

02961\_02

Fig. 25: Function diagram of voice control system

Index	Explanation
1	Telematics control unit
2	Car communication computer
3	Central information display
4	Audio output
5	Controller with PTT button
6	Hands-free microphone as an alternative if no telephone is installed
7	Hands-free microphones of telephone system

### **System start/end**

The voice control system is activated/deactivated via the push-to-talk button (PTT) on the multifunction steering wheel or on the controller. For the first time, the PTT button on the controller makes it possible for the passenger to use the voice control system (SES). The SES is activated for the driver by briefly pressing the button and for the passenger by pressing and holding the button longer.

The SES is deactivated by again pressing one of the PTT buttons.

Activation of the SES is indicated by a graphic display (PTT logo) in the status line of the CID. The system is active for about 5 seconds. If no input takes place during this period of time, the user is informed that no voice input was detected and the request for voice input is repeated. The voice control system is deactivated if again no input is made within 5 seconds.

### **- TV function**

The TV function can be optionally ordered in connection with the car communication computer. The central information display CID in the instrument panel serves as the monitor for the TV function.

Since, in the majority of countries, the TV function is prohibited while driving for safety reasons, the TV function is switched off from a speed > 5 km/h.

The following components are necessary for the TV function:

- TV aerials
- TV aerial amplifier (in FM diversity module)
- Video module
- Car communication computer
- Central information display
- Controller
- Audio system

Functional principle of TV function

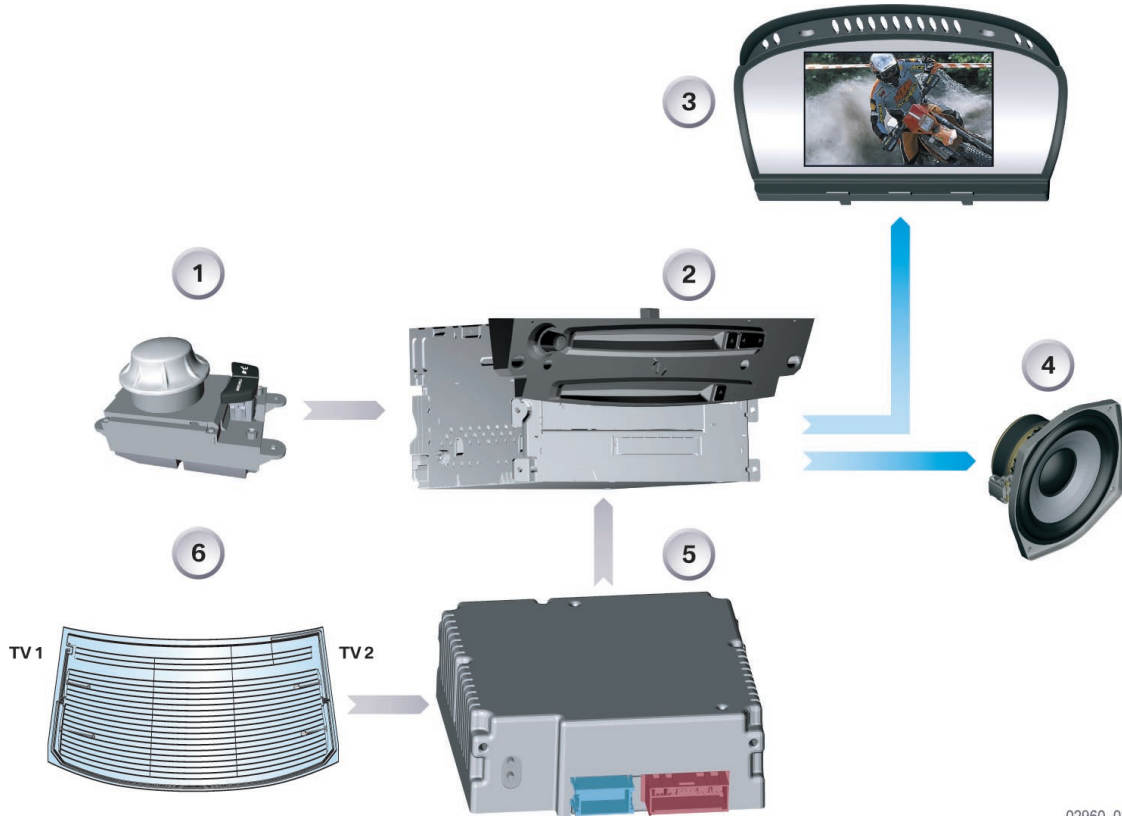

KT-11740

02960\_02

Fig. 26: Function diagram of TV function

Index	Explanation
1	Controller
2	Car communication computer
3	Central information display
4	Audio output
5	Video module with TV aerial diversity
6	Rear window with TV aerials and TV aerial amplifier

## TV aerials

The two TV aerials TV1 and TV2 are located in the rear window pane. The heating elements of the rear window defogger are used as the aerials.

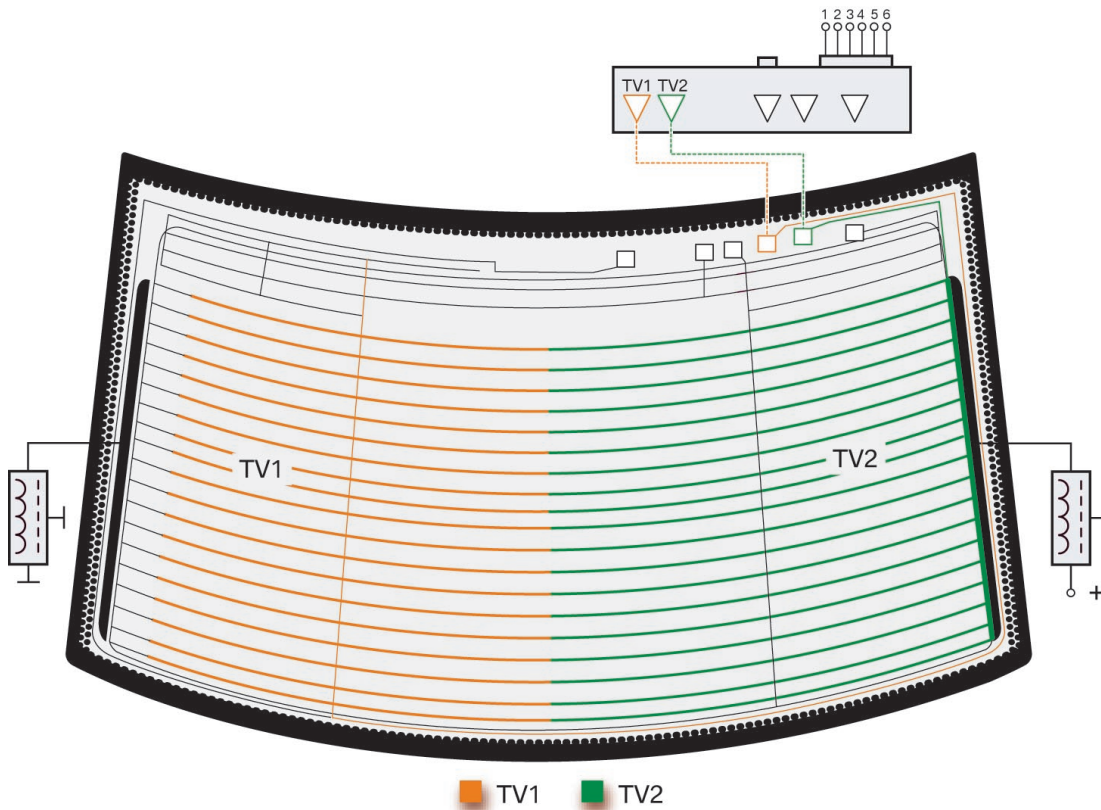

KT-11108

Fig. 27: TV aerial configuration

02397\_02

## TV aerial amplifier

The TV aerial amplifiers for TV1 and TV2 are located in the FM aerial diversity. The FM aerial diversity system is secured directly on the rear window. Electrical connection is made by spring contacts. The aerial signals are transmitted via coaxial cables to the video module.

## Remote aerial feed

The video module supplies voltage to the aerial amplifiers in the FM aerial diversity module via the aerial cable.



## **Video module 5**

The video module 5 (VM 5) known from the E65 is used in the E60. Depending on the configuration, the VM 5 will be available in the following variants:

- VM 5 FBAS = ECE variant
- VM 5 RGB = Japan variant with external navigation system
- VM 5 Drive = for rear compartment entertainment (not at SOP)

The VM 5 with FBAS output is used in the ECE variant for the stationary TV function with the CID. The car communication computer is capable of processing the FBAS or RGB signal. The difference between the two variants is in the colour decoding.

In the case of VM 5 FBAS, colour decoding takes place in the car communication computer. With VM 5 RGB, colour decoding takes place in the video module.

In all variants, the video modules 5 feature the following functions:

- TV reception
- Video text reception with page memory
- Remote aerial feed
- Self-diagnosis

The video module is located on the rear left in the luggage compartment.

## **TV reception**

The VM 5 is designed for all TV standards and frequencies worldwide. The correct standard and frequencies are set by selecting the country in the CID. After selecting the TV standard, the receivable TV stations of a country can be chosen. In border areas it is possible to receive the TV stations of the neighbouring country by changing the country selection.

The TV signals are transmitted from the two TV aerials via separate coaxial cables to the VM 5. The VM 5 is a single tuner unit. The two aerials are connected to the tuner. The tuner selects the aerial with the strongest reception for reproducing the TV channel (aerial diversity).

The video module compiles a list of all receivable stations. The station list is transmitted via the asynchronous channel of the MOST bus to the car communication computer and shown in the CID.

The station list is arranged in alphabetical order by the VPS signal based on the station names (ARD, BR3, SAT1,...). If no VPS signal is received, the station list is arranged according to channels (CH5, CH7, CH12,...).

The received TV sound in mono is digitized in the video module and applied parallel to the left and right channel of the MOST bus. The audio signals are transmitted on the synchronous channel of the MOST bus to the car communication computer and output via the audio systems.

## **Video text reception**

The video module 5 is capable of receiving and outputting video text. A memory for about 1000 pages is available. The video text files are transmitted via the asynchronous channel of the MOST bus to the car communication computer. The text files are processed by the MMI in the car communication computer and shown on the CID.

### **Car communication computer**

Conversion of the analogue picture information (FBAS signals) sent from the video module into digital LVDS signals takes place in the car communication computer. The LVDS signals are transmitted via a special LVDS cable to the CID.

### **Central information display**

The central information display serves as the screen for the TV function and video texts.

### **Controller**

The controller is used to operate the TV functions.

### **Audio system**

The audio sound for the TV function is output via the vehicle's audio system.

### **- Online services**

The customer can use online services in connection with SA 613 Internet-based services, SA 616 Online platform and the car communication computer.

SA 616 Online platform contains the HW/SW module (browser) and facilitates technical implementation in the vehicle.

SA 613 Internet-based services is the application and makes available an entire services package. The application corresponds to that of the E65/66. The functionalities are essentially identical. The same is true for the user interface as the same icons are used. The only difference is in the way the pages are changed. In the E65/66 the pages are turned while in the E60/E63 they are scrolled.

## **E63/E64 Audio systems**

### **- Introduction**

This technical documentation describes the differences in the audio systems of the E63/E64 compared to the E60. The following audio systems are available for the E63/E64:

- HiFi audio system
- Top-HiFi audio system

The audio HiFi system is the standard system. The Top-HiFi audio system is available as an option. The audio systems of the E63/E64 correspond to the defined audio standards.

With regard to their functionality and performance the audio systems correspond to those of the E60. The audio systems have been adapted to the E63/E64 interior.

- System overview HiFi E63/E64

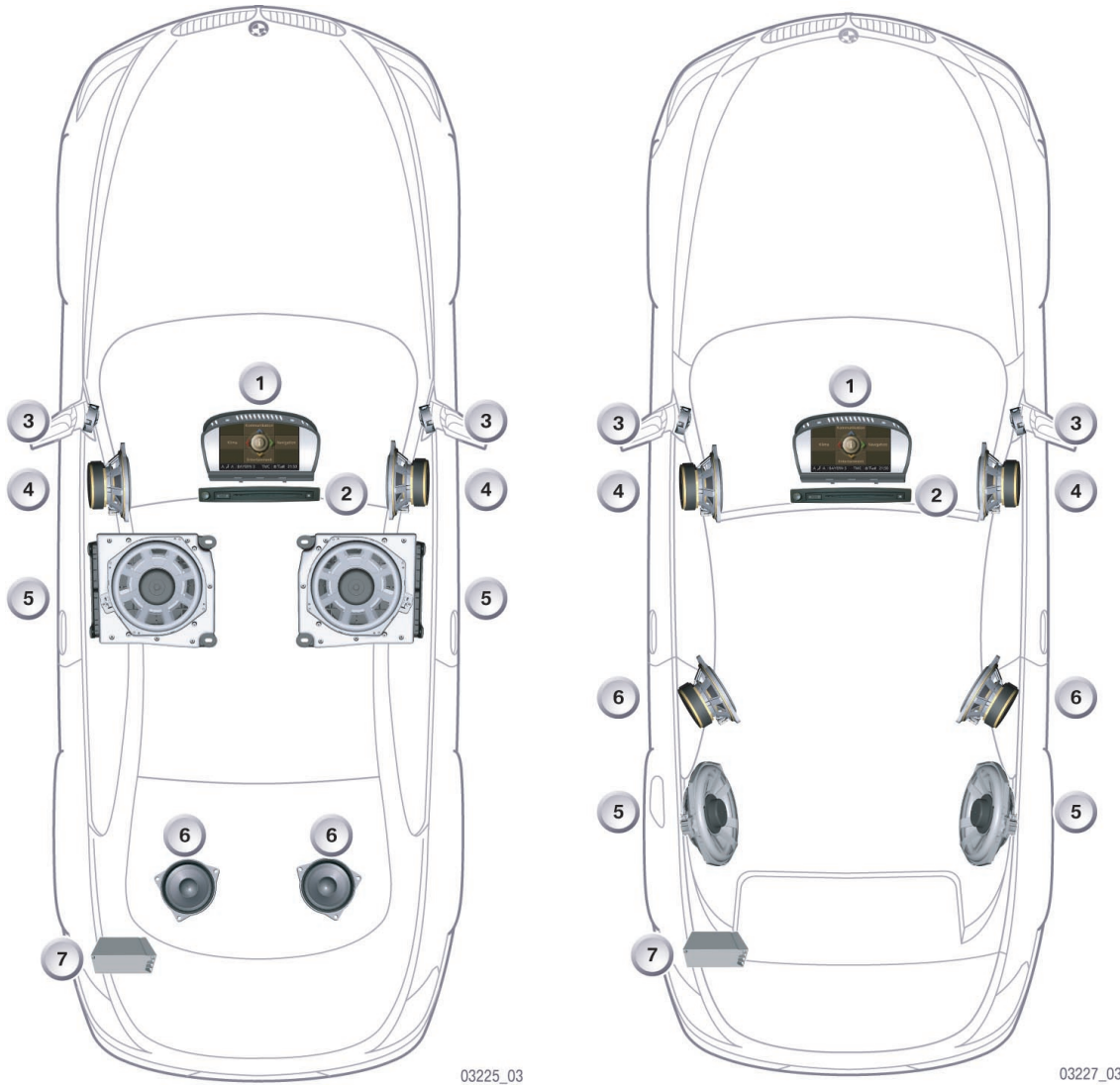

KT-11994

03225\_03

03227\_03

KT-11996 Fig. 28: Arrangement of the components of the HiFi audio systems in the E63 (left) and E64 (right)

Index	Explanation	Index	Explanation
1	Central information display	5	Central woofers
2	Multi-audio system controller	6	Mid-range speaker, rear
3	Tweeter, front	7	HiFi amplifier
4	Mid-range speaker, front		

System circuit diagram HiFi E63

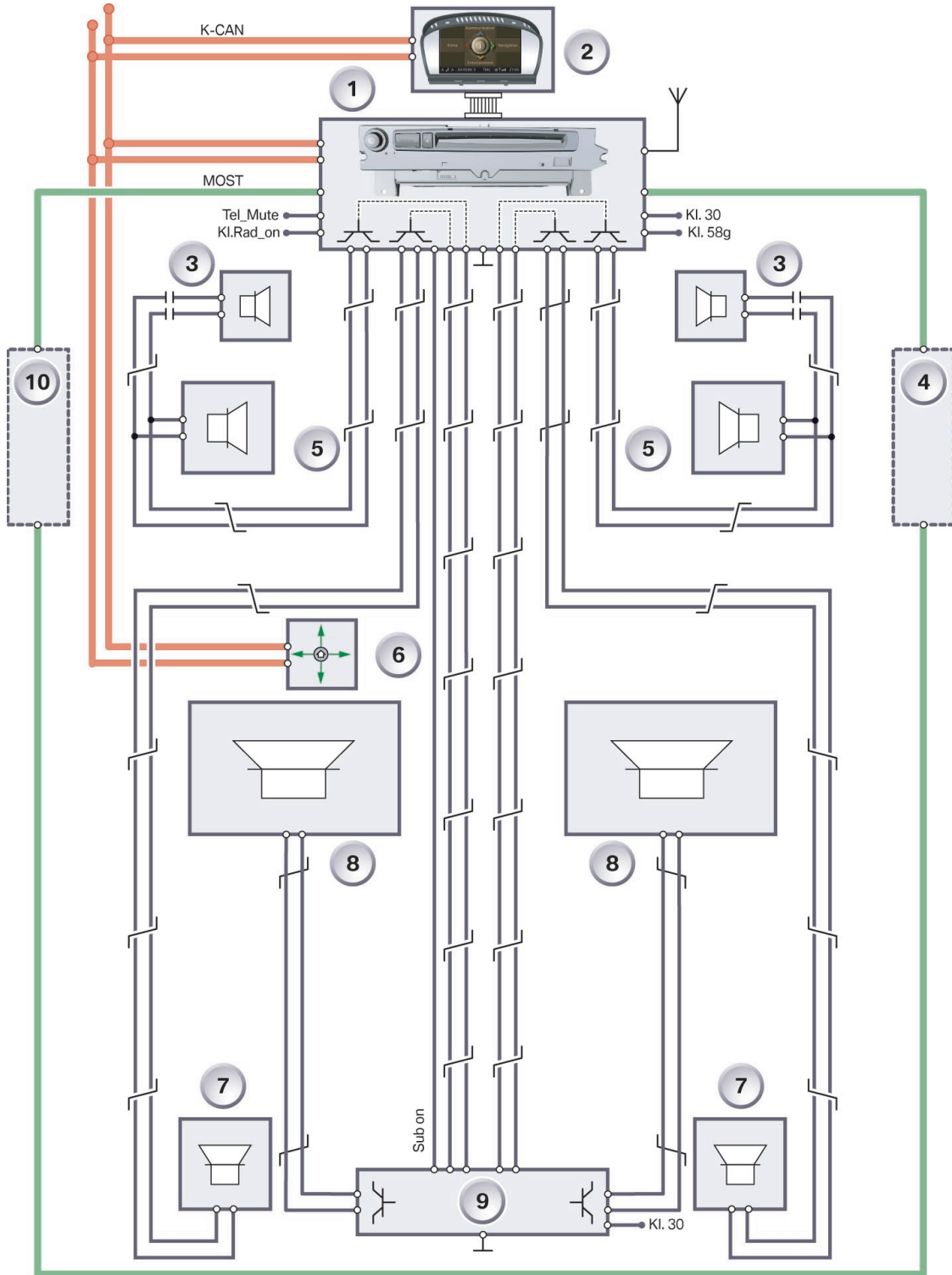

KT-11985

03221\_03

Fig. 29: System circuit diagram HiFi E63

System circuit diagram E64

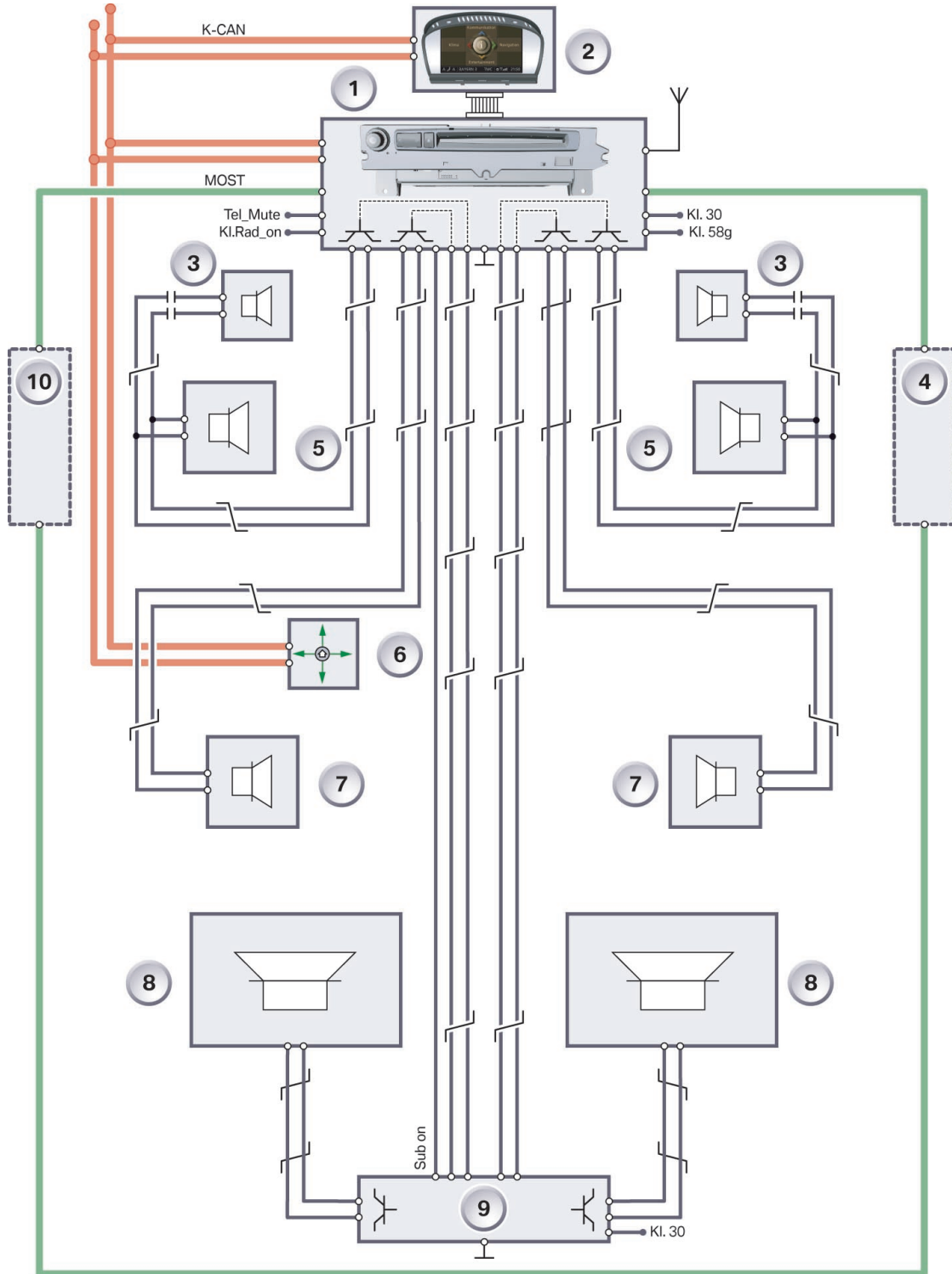

KT-11987

Fig. 30: System circuit diagram HiFi E64

03223\_03

Index	Explanation
1	Multi-audio system controller
2	Central information display
3	Tweeter, front
4	Other MOST bus users corresponding to option configuration
5	Mid-range speaker, front
6	Controller
7	Mid-range speaker, rear
8	Central woofers
9	HiFi amplifier
10	Other MOST bus users corresponding to option configuration
Tel_Mute	Telephone signal for muting audio system
Kl.Rad_on	Signal for switching on aerial diversity
Kl.30	Voltage supply, terminal 30
Kl.58g	Instrument lighting, terminal 58g

### HiFi audio system

The HiFi audio system is installed as standard in the E63/E64. The HiFi audio system in the E63/E64 differs with regard to the different layout of the woofers.

#### Woofers (bass speaker)

Two woofers are used in connection with the HiFi audio system. The woofers have a diameter of 200 mm and a load rating of 40 W. The effective frequency range is from 30 Hz to 500 Hz.

On the E63, the woofers are located under the driver's/passenger's seat.

The woofers in the E64 are fitted in the rear side trim panel next to the rear seat.

The woofers are located in different positions because of the seats. A seat with an integrated seat belt is used on the E64. The seat support is reinforced as the entire force has to be transmitted into the seat in the event of a crash. Consequently there is no package space available for the woofer.



- System overview Top-HiFi E63/E64

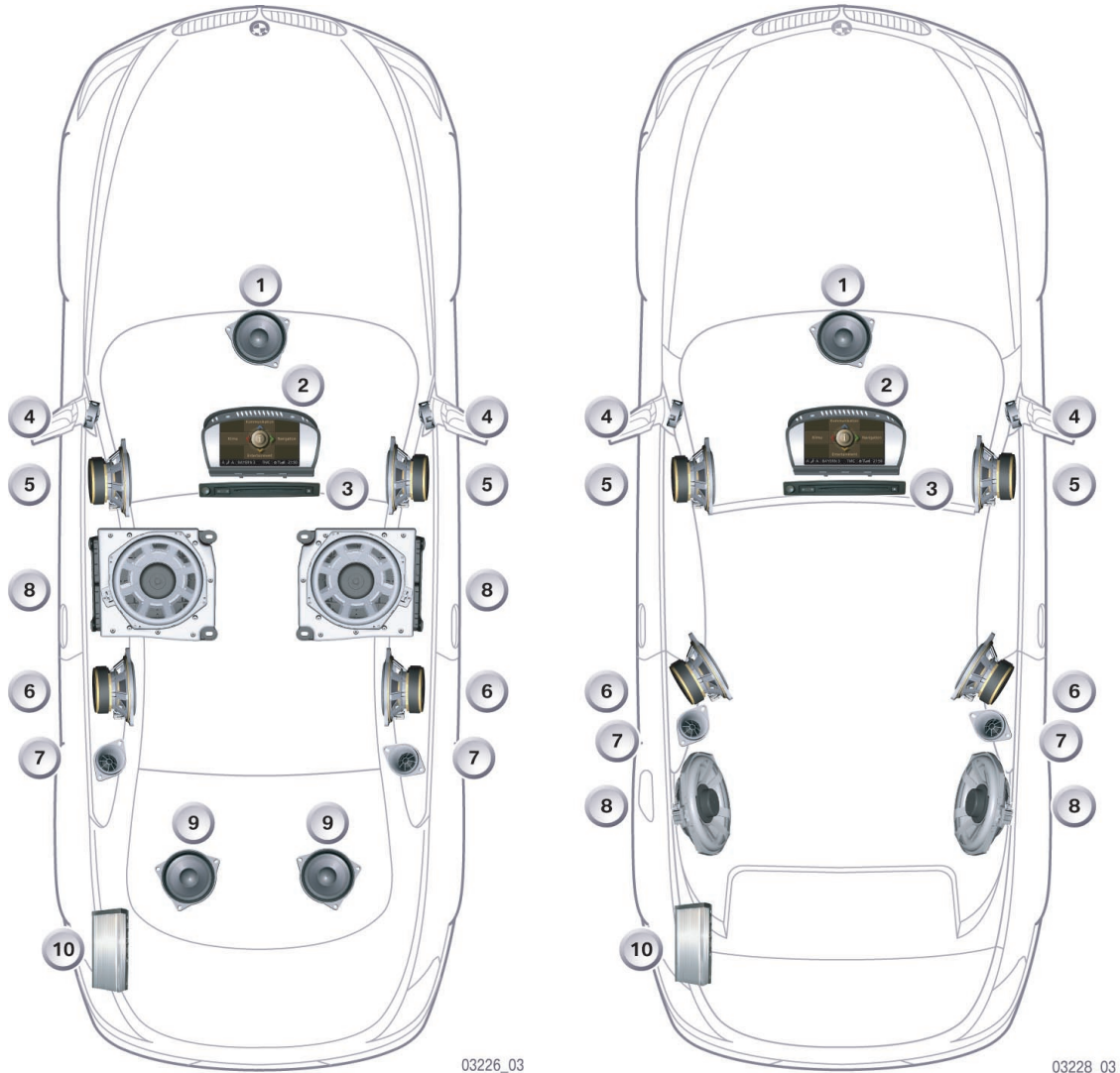

KT-11995

03226\_03

03228\_03

Fig. 31: Arrangement of the components of the Top-HiFi audio systems in the E63 (left) and E64 (right)

KT-11997

Index	Explanation	Index	Explanation
1	Central mid-range speaker, front	6	Mid-range speaker, centre
2	Central information display	7	Tweeter, rear
3	Multi-audio system controller	8	Central woofers
4	Tweeter, front	9	Mid-range speaker, rear on rear window shelf, E63 only
5	Mid-range speaker, front	10	Top-HiFi amplifier

System circuit diagram Top-HiFi E63

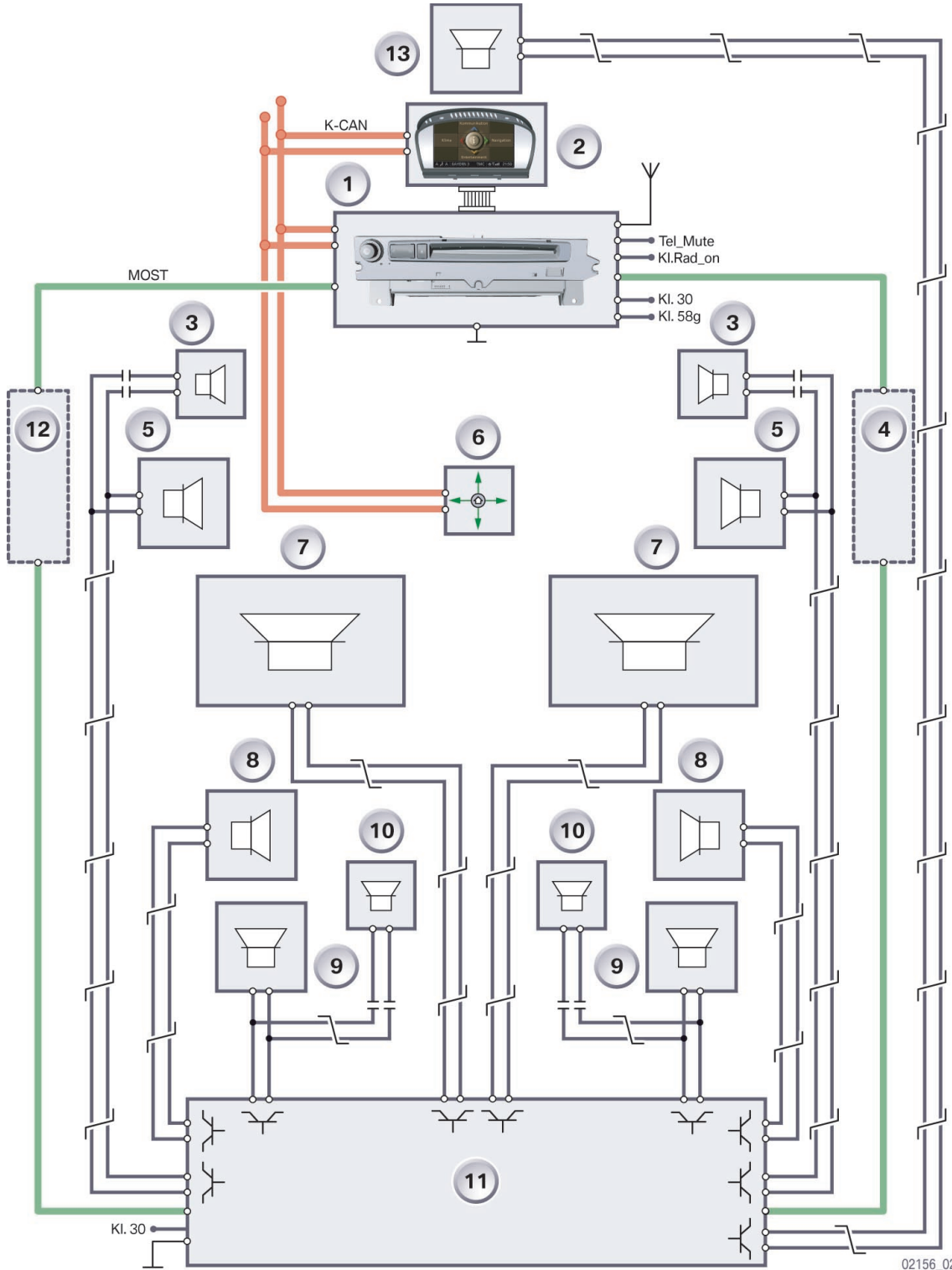
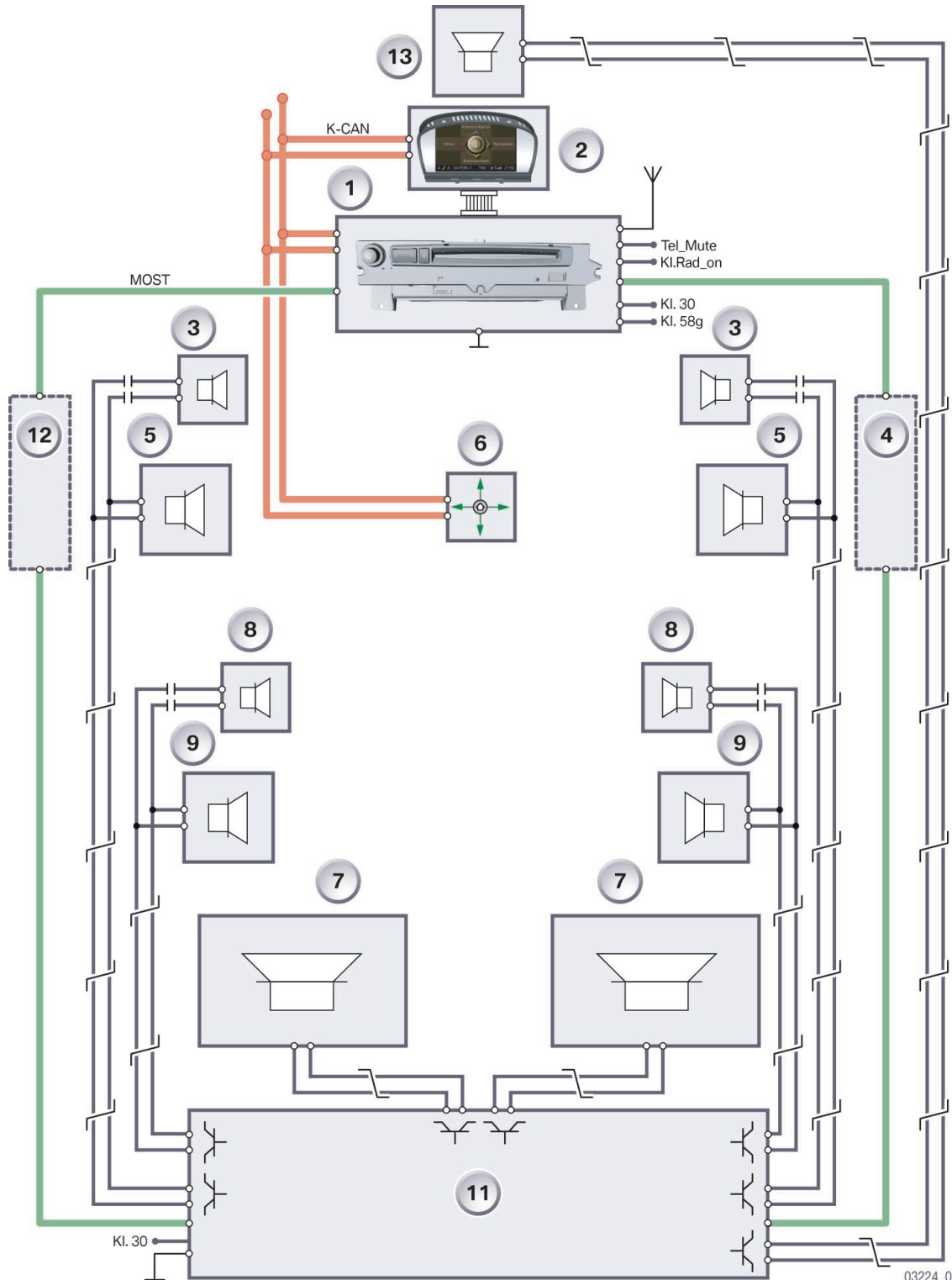

Fig. 32: System circuit diagram Top-HiFi E63

System circuit diagram Top-HiFi E64



KT-11988

03224\_03

Fig. 33: System circuit diagram Top-HiFi E64

Index	Explanation
1	Multi-audio system controller
2	Central information display
3	Tweeter, front
4	Other MOST bus users corresponding to option configuration
5	Mid-range speaker, front
6	Controller
7	Central woofers
8	Tweeter, rear
9	Mid-range speaker, centre (surround sound)
10	Mid-range speaker, rear on rear window shelf, E63 only
11	Top-HiFi amplifier
12	Other MOST bus users corresponding to option configuration
13	Central mid-range speaker, front (surround sound)
Tel_Mute	Telephone signal for muting audio system
Kl.Rad_on	Signal for switching on aerial diversity
Kl.30	Voltage supply, terminal 30
Kl.58g	Instrument lighting, terminal 58g

### Top-HiFi audio system E63/E64

The Top-HiFi audio system is available as an option. The Top-HiFi audio system differs from the HiFi audio system by higher grade speakers:

The mid-range speakers feature aluminium diaphragms while the tweeters have spherical caps made of aluminium. The speakers were adapted corresponding to the higher output power of the Top-HiFi amplifier.

For space reasons there are only 5 mid-range speakers available in the E64. Spatial sound is generated in the E64 by the 5 mid-range speakers. For this purpose, the signals are recalculated by an algorithm and output on 5 channels. The Top-HiFi amplifier in the E64 is of identical design as that in the E63.

## Telephone system

### Universal mobile phone preparation

With the introduction of the E63, SA 644 Universal mobile phone preparation will be available for the E60 and E63 vehicles. SA 644 Universal mobile phone preparation is a universal charging and hands-free facility ULF for Bluetooth mobile phones based on GSM standard.

The universal charging and hands-free facility (ULF) forms the interface between the Bluetooth mobile phone and the vehicle. Consequently, virtually all commercially available Bluetooth mobile phones can be connected to the vehicle.

The universal charging and handsfree facility is already used in other models with K-bus connection. In connection with the E6x model series, the ULF was adapted to facilitate integration in the MOST ring.

The universal charging and hands-free facility is **not** a transceiver and only serves the purpose of connecting an individual mobile phone with Bluetooth interface to the vehicle. A voice control system is also integrated in the ULF. This makes it possible for the customer to use the following functions in the vehicle through his/her personal mobile phone:

- Hands-free operation
- Recharging the mobile phone batteries
- Sending and receiving via the external vehicle aerial
- Control of various mobile phone functions by means of voice commands
- Operation of the mobile phone via the controller and MMI

## System overview

### Inputs/outputs

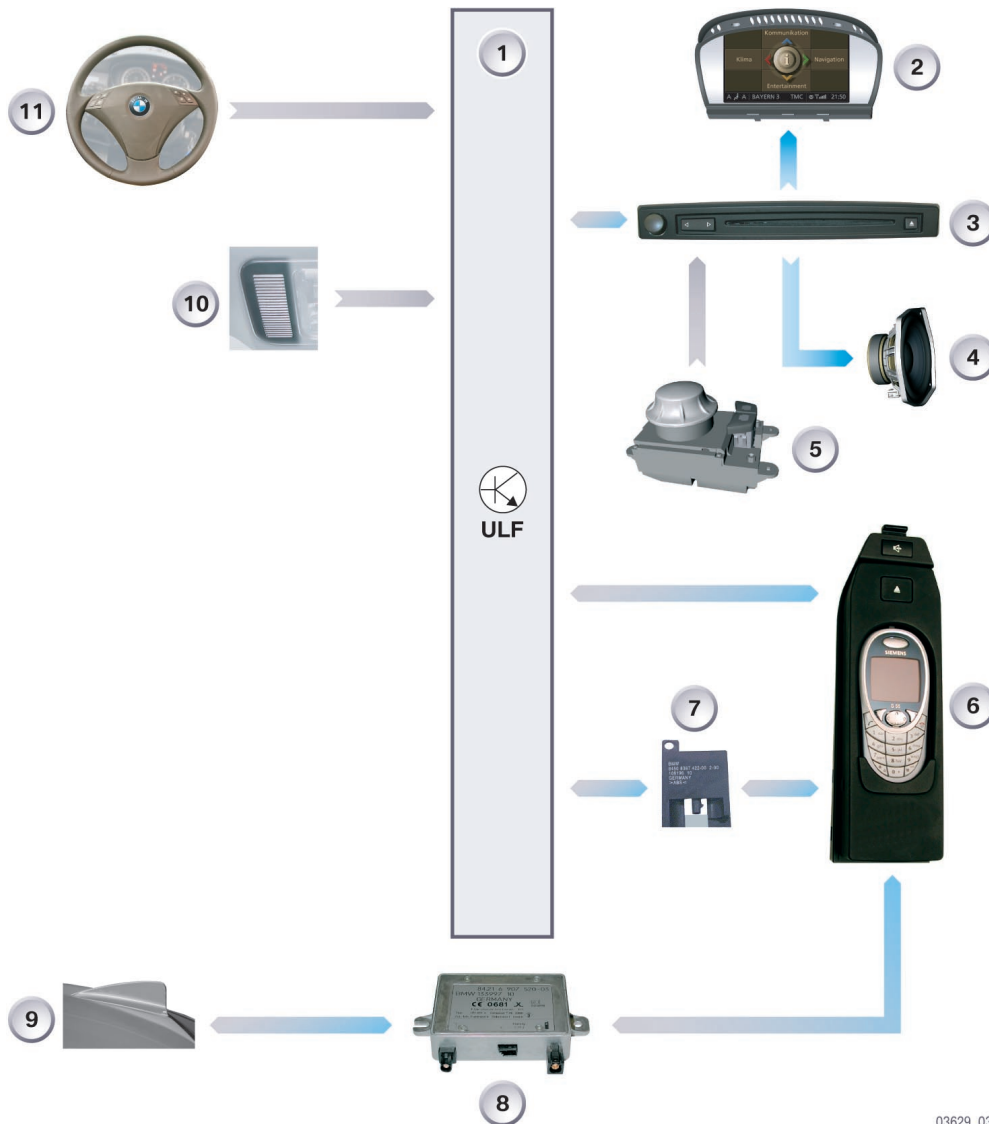

KT-12363

03629\_03

Fig. 34: System overview universal charging and hands-free facility

Index	Description	Index	Description
1	ULF control unit	7	Bluetooth aerial
2	Central information display	8	Compensator
3	Multi-audio system controller	9	GSM roof aerial
4	Speaker	10	Hands-free microphone
5	Controller	11	Transmit/receive button on MFL
6	Base plate with snap-in adapter		

### System circuit diagram

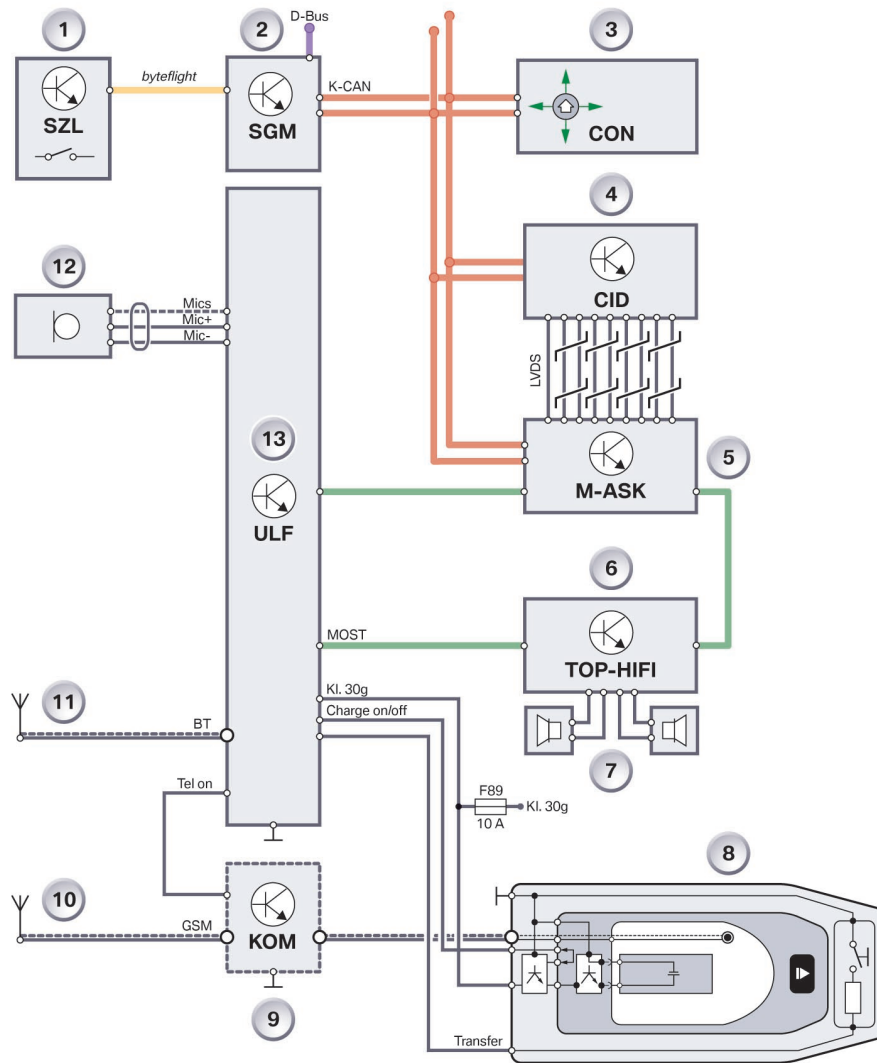

KT-12369

03251\_03

Fig. 35: System circuit diagram universal charging and hands-free facility

Index	Description	Index	Description
1	Transmit/receive button on MFL	8	Base plate with snap-in adapter
2	Safety and gateway module	9	Compensator
3	Controller	10	GSM aerial
4	Central information display	11	Bluetooth aerial
5	Multi-audio system controller	12	Hands-free microphone
6	Top-HiFi amplifier	13	ULF control unit
7	Speaker		

## - Components

The universal mobile phone preparation is suitable for various Bluetooth mobile phones, consisting of following components:

- Electronic universal charging and hands-free module ULF (control unit)
- Base plate
- Hands-free microphone
- GSM aerial
- Bluetooth aerial
- Multifunctional steering wheel
- Multi-audio system controller or car communication computer

To be able to use all the telephone functions, the customer still requires the following components that are not included in the universal mobile phone preparation as they are customer-specific.

- Mobile phone with Bluetooth interface
- Snap-in adapter
- Line compensator (optional)

## - **Electronic universal charging and hands-free module ULF**

The universal charging and hands-free facility is **not** a transceiver and only serves the purpose of connecting an individual mobile phone with Bluetooth interface to the vehicle.

The ULF contains the following assemblies:

- The DSP module for controlling the digital full-duplex hands-free facility
- The Bluetooth module for data transmission between the mobile phone and vehicle
- An MOST bus interface for transmitting control commands and outputting the AF signals via the speakers
- A voice recognition system for controlling telephone functions
- An aerial interface for the Bluetooth aerial



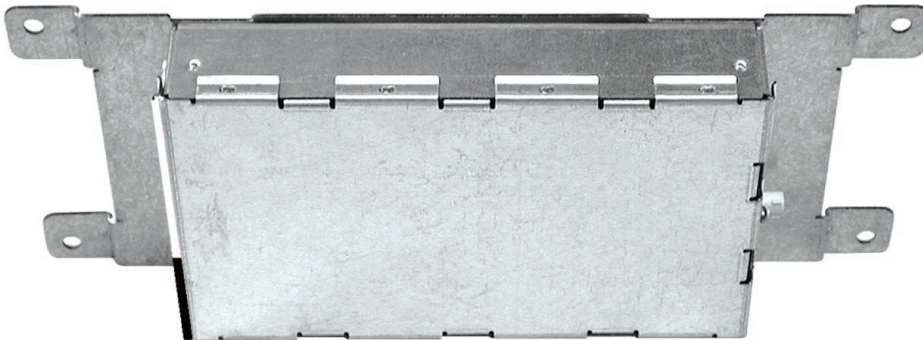

03KTF-12024

Fig. 36: ULF control unit

The ULF on the E60 is located in the luggage compartment on the rear left wheel arch. On the E63, the ULF is located on the left-hand partition in the vehicle interior.

### **Functional principle**

There are several modules integrated in the ULF control unit. The various modules facilitate connection of a commercially available Bluetooth mobile phone to the vehicle.

The main modules of the ULF are described in the following. The ULF consists of the following modules:

- Bluetooth module
- Hands-free module
- Voice control module
- Interface for MOST bus

## **Bluetooth module**

A coaxial cable connects the Bluetooth module directly to the Bluetooth aerial. The Bluetooth module functions on the basis of the Bluetooth specification 1.1. This specification contains various Bluetooth profiles which contain the rules for data exchange for the Bluetooth users. The Bluetooth module contains the following Bluetooth profiles:

- Headset profile (audio data transmission)
- Hands-free profile (hands-free telephone)
- Phone access profile (phonebook entries)
- Generic access profile (authentication)

These profiles must also be implemented in the mobile phone in order to be able to use all the functions of the universal charging and hands-free facility. The Bluetooth module sets up the connection for voice input and output between the mobile phone and vehicle.

## **Hands-free module**

With the aid of a DSP (**D**igital **S**ound **P**rocessor), the hands-free module controls the input/output of the AF signals in hands-free mode. A telephone call is always conducted in hands-free mode when it is accepted by means of the acceptance button in the MFL or the menu button in the CID.

On entering the vehicle after accepting the call on the mobile phone, the customer can transfer the call to the hands-free facility by pressing the transfer button on the eject box. It is not possible to switch over from hands-free to privacy mode with the transfer button.

Voice transmission in hands-free mode takes place via a microphone in the front roof console. The microphone is used for hands-free operation and for the basic voice control system (telephone functions). Noise suppression and echo compensation of the microphone for hands-free mode always takes place in the ULF.

Two microphones are used on vehicles equipped with the car communication computer and high version of the voice control system. The AF signals of both microphones are routed to the ULF. The AF signals for hands-free operation are processed in the ULF.

If the PTT button is pressed while the voice control system is active, the AF signals will be sent via the MOST bus to the car communication computer where they are processed. The reason for the different procedures is attributed to the implementation of the voice control system SES in the car communication computer.

The hands-free facility is a full duplex transmission system for simultaneous listening and speaking.

### **Interface for MOST bus**

The interface for the MOST bus controls the way data telegrams are sent and received on the MOST bus to other users.

### **Voice control module**

Due to the available computer and memory capacity, it is not possible to incorporate the voice control system directly in the M-ASK. A voice input module is integrated in the ULF for the purpose of realizing voice control of the mobile phone. This is the basic voice control system. It enables operation and control of the telephone only.

The basic voice control system is available in the following languages:

- German
- English UK
- English US
- French
- Spanish
- Italian

### **ULF with basic voice control system**

In connection with the basic voice control system, only the telephone functions can be controlled by way of voice recognition. There is no visual feedback of the input commands on the central information display.

The following telephone functions can be controlled with voice command:

- Entering telephone numbers
- Correcting entries
- Reading entries
- Confirming entries
- Selecting numbers
- Storing names
- Selecting names
- Deleting names
- Reading phonebook
- Selecting and entry while reading
- Clearing phonebook
- Help function
- Cancel function

**- Eject box**

The eject box consists of two parts:

- Base plate
- Snap-in adapter

The eject box is located in the centre console under a cover in the centre armrest.

**Base plate**

The base plate with cover is included in the scope of delivery of the Universal mobile phone preparation. The base plate serves the purpose of accepting the snap-in adapter and therefore the Bluetooth mobile phone. The base plate establishes the connection to the universal charging and hands-free facility and to the vehicle wiring harness and contains the charging module. The base plate is supplied with a cover.

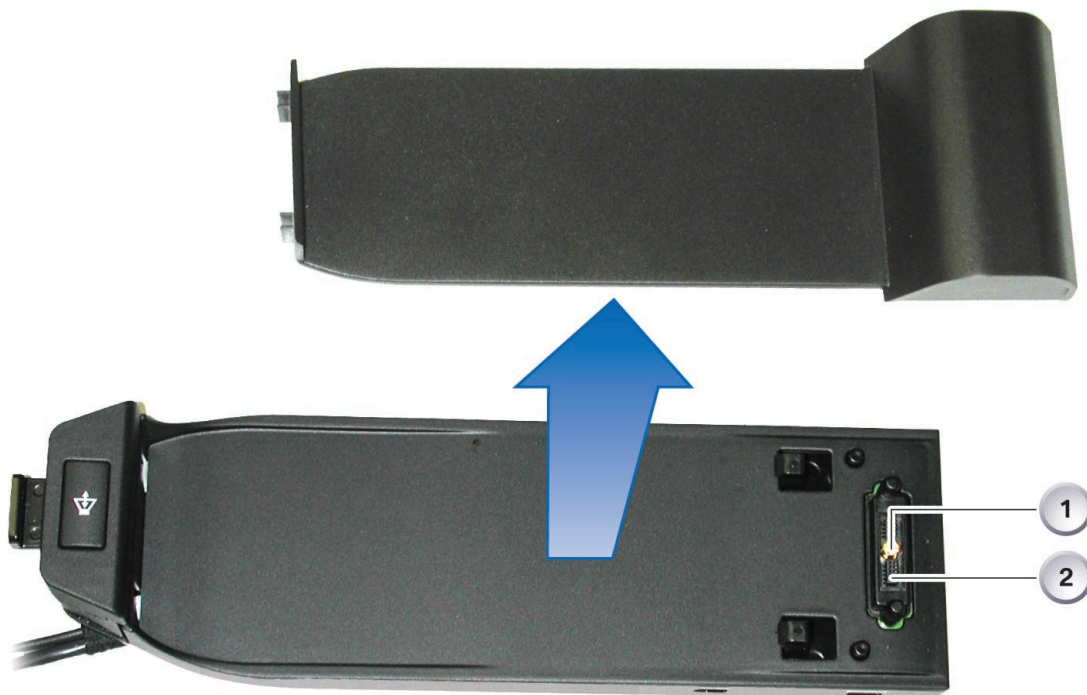

KT-12021

03250\_03

Fig. 37: Base plate with cover

Index	Description	Index	Description
1	Aerial connection	2	Power supply

### Snap-in adapter

A specific snap-in adapter is necessary corresponding to the type of Bluetooth mobile phone used. The corresponding snap-in adapter is available as a BMW accessory.

An electronic charging module matching the type of mobile phone used is integrated in the snap-in adapter. The electronic charging module features contacts for the power supply used for charging the battery in the mobile phone. An input filter and a switch-on control are integrated in the electronic charging module. The mobile phone controls the battery charge as required.

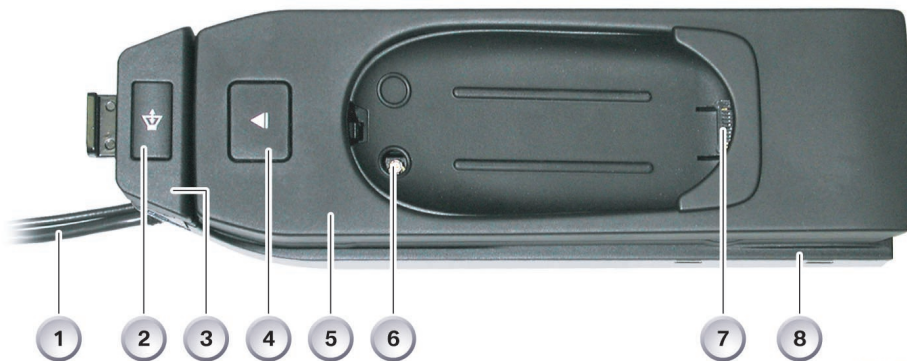

KT-12019

03248\_03

Fig. 38: ULF eject box (base plate with snap-in adapter)

Index	Description	Index	Description
1	Connection cable	5	Snap-in adapter
2	Transfer button	6	Aerial connection
3	Eject button, snap-in adapter	7	Charging contacts
4	Eject button, Bluetooth mobile phone	8	Base plate

### Eject box with Bluetooth mobile phone



KT-12020

03249\_03

Fig. 39: ULF eject box with Bluetooth mobile phone

**- Bluetooth mobile phones**

Essentially, all Bluetooth mobile phones can be operated with the universal charging and hands-free facility. The prerequisite is that the corresponding profile is stored in the mobile phone. However, a specific snap-in adapter is necessary for each mobile phone. For economic reasons, in future only snap-in adapters for the most commonly used Bluetooth mobile phones will be developed.

## - GSM aerial

The GSM aerial is designed as a dual band aerial and is set to the frequency ranges 900/1800 MHz. The GSM aerial is located together with the GPS aerial in the roof aerial. The GSM aerial is connected directly to the mobile phone holder and therefore to the mobile phone.

For health reasons, the mobile phone should always be kept in the eject box so that the high output power is not emitted via the mobile phone aerial but rather through the external aerial. In addition, it is possible that using the mobile phone in the vehicle interior can cause disturbances in other vehicle systems.

## - Compensator

Losses may occur in the transmission power output due to the length of the aerial lines. Therefore, a compensator that compensates for the losses in the aerial output can be connected between the base plate and GSM aerial as required.

The compensator for the ULF is not a booster for increasing the output power but rather it is only suitable for compensating for power losses. The compensator is installed on the rear left in the luggage compartment as required.



KT-10548

1942\_02

Fig. 40: Aerial line compensator for ULF

## - Bluetooth aerial

The Bluetooth aerial operates in the ISM band (Industrial Science Medical Band) at a frequency of 2.45 GHz. The Bluetooth aerial is located on the centre tunnel beneath the controller. The Bluetooth aerial establishes the radio interface between the mobile phone and vehicle.



## **- ULF system functions**

The universal charging and hands-free facility ULF is the interface between the Bluetooth mobile phone and the vehicle. It combines the functions of the Bluetooth mobile phone with the telephone functions of the vehicle.

The transceiver unit is the Bluetooth mobile phone. The GSM aerial is connected via the baseplate and the snap-in adapter directly to the mobile phone.

The Bluetooth mobile phone should always remain placed and engaged in the snap-in adapter while driving.

Advantages:

- Reduction in the risk of injury caused by loose objects (e.g. Bluetooth mobile phone) in the vehicle interior while braking hard.
- Connection of GSM roof aerial therefore considerably reducing radiation exposure of the user
- Continuous monitoring of battery charge status
- Avoiding interference from other vehicle systems

The telephone functions, however, are maintained even when the Bluetooth mobile phone is in any other location in the vehicle e.g. in a briefcase or in the handbag

## **- Telephoning**

### **Call acceptance**

A call is accepted by pressing the send/receive button on the multi-function steering wheel, mobile phone or in the menu button of the CID.

A ring tone sounds in the Bluetooth mobile phone when a telephone signal is received via the GSM aerial. At the same time, a signal is sent via the Bluetooth interface in the mobile phone to the Bluetooth aerial in the vehicle. The Bluetooth aerial is connected to the Bluetooth module in the universal charging and hands-free facility ULF.

The ULF recognizes the incoming call and sends an MOST telegram to mute the audio output. The DSP (**D**igital **S**ignal **P**rocessor) enables the speakers for outputting the tone signal and the tone signal sounds in the vehicle.

The following options are available for accepting a call:

- Pressing send/receive button on the multifunction steering wheel
- Pressing the send/receive button on the Bluetooth mobile phone
- Press send/receive button in central information display

### **Call routing**

If accepted by pressing the send/receive button on the multifunction steering wheel, a call is routed via the hands-free microphone and vehicle speakers. If accepted by pressing the send/receive button on the mobile phone, a call is routed via the mobile phone (privacy mode).

It is possible to switch between privacy mode and hands-free mode at any time by pressing the transfer button.

The hands-free facility is switched active after pressing the send/receive button. The incoming call is encrypted via the Bluetooth interface in the mobile phone and sent to the Bluetooth aerial in the vehicle. The Bluetooth aerial connected to the ULF receives the call and converts it into audio signals.

The audio signals are transmitted in the form of telegrams via the MOST bus to the M-ASK that outputs these telegrams via the vehicle speakers. On vehicles equipped with a Top-HiFi amplifier, the audio signals are output via the MOST bus directly to the amplifier. The Top-HiFi amplifier accepts the audio signals from the MOST bus and outputs them via the vehicle speakers.

Since the vehicle is equipped with a digital full duplex hands-free facility, it is possible to speak and hear a call simultaneously. An echo compensation facility prevents feedback when speaking into the microphone. The microphone signal is sent via an AF line to the ULF where the received AF signal is encoded in the Bluetooth module and transferred via the Bluetooth aerial to the mobile phone. The Bluetooth mobile phone sends the call via the GSM aerial to the user.

## **Ending call**

A call is ended by pressing the same send/receive buttons used to receive the call. The mobile phone has its own button for ending calls.

The following options are available for ending a call:

- Again pressing the send/receive button on the multifunction steering wheel
- Pressing the end call button on the Bluetooth mobile phone
- Pressing the end button in the central information display

## Telecommunication services

### - Introduction

In addition to the general telephone functions, in connection with additional SAs, the TCU offers further telecommunication services.

The available telecommunication services are divided into the following areas:

- SA 638 Telephone (call functions)
- SA 607 TeleService 1 preparation (service functions)
- SA 612 BMW ASSIST (information and emergency call functions) including SA 605 Telematics preparation
- BMW Online services (Internet functions)

Telematics is an artificial word coined from the terms **tele**communication and **inform**atics. At BMW, the term Telematics stands for extended functions that facilitate the exchange of information to and from the vehicle.

In EU vehicles, coupling with the optional navigation system is necessary for the majority of telematics functions. All telematics functions are options and country-specific.

Certain prerequisites must be created in the specific countries in order to be able to fully utilize all telematics functions. Such prerequisites include a service provider that accepts the incoming calls 24 h a day and passes them on to the corresponding terminals.

### **- General telephone function**

The following functions are available if only the option SA 638 Car telephone Professional (GSM) is ordered:

- Emergency call without SIM card (112)
- Manual emergency call via emergency call button (112)
- Automatic emergency call via crash signal (112)
- Entry of dealer number during pre-delivery inspection
- Entry of hotline number during pre-delivery inspection
- Entry of mobile service number during pre-delivery inspection

### **Emergency call functions without navigation (without SA 609)**

If no navigation system is ordered, the country-specific emergency call number (112) is selected when an emergency call is triggered (manually/automatically). An attempt is made to establish a voice connection from the rescue control centre in order to obtain further information with regard to the location and number of injuries.

**Note:** An emergency call is possible at any time even if no customer SIM card is inserted.

The programmed number of the mobile service is dialled in connection with a breakdown call.

- Telecommunication services without navigation system

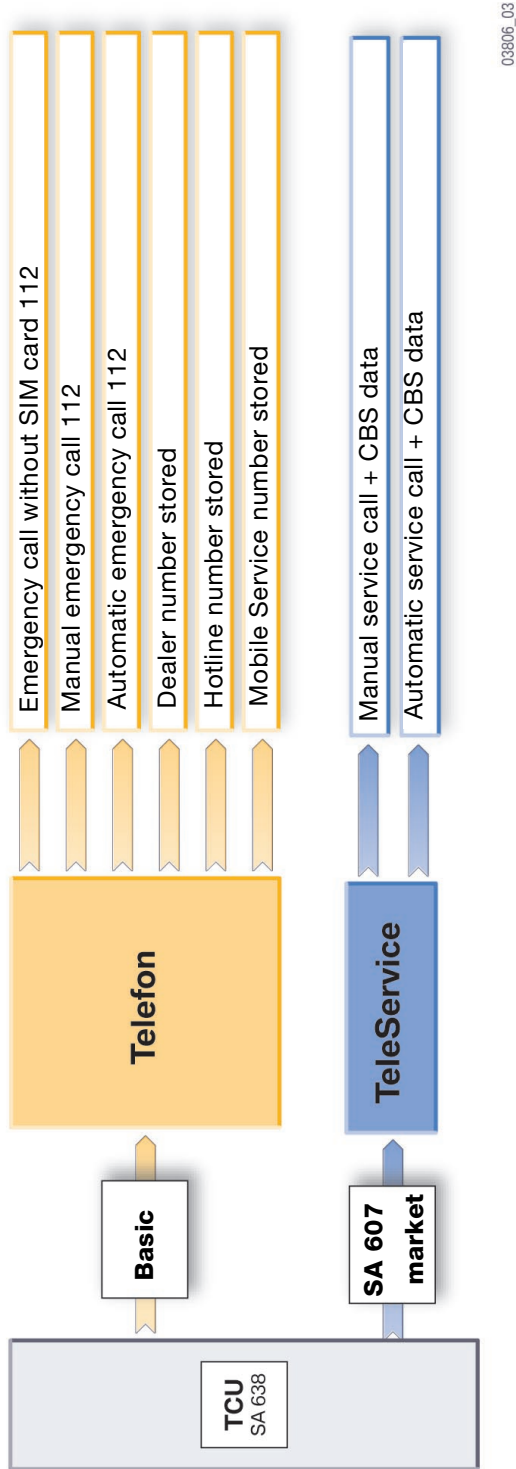

KT-12587

Fig. 41: Telephone and TeleService 1 without navigation

## - Telecommunication services US

The option 639 Complete telephone preparation including telematics and TeleService 1 is offered for the country-specific version USA.

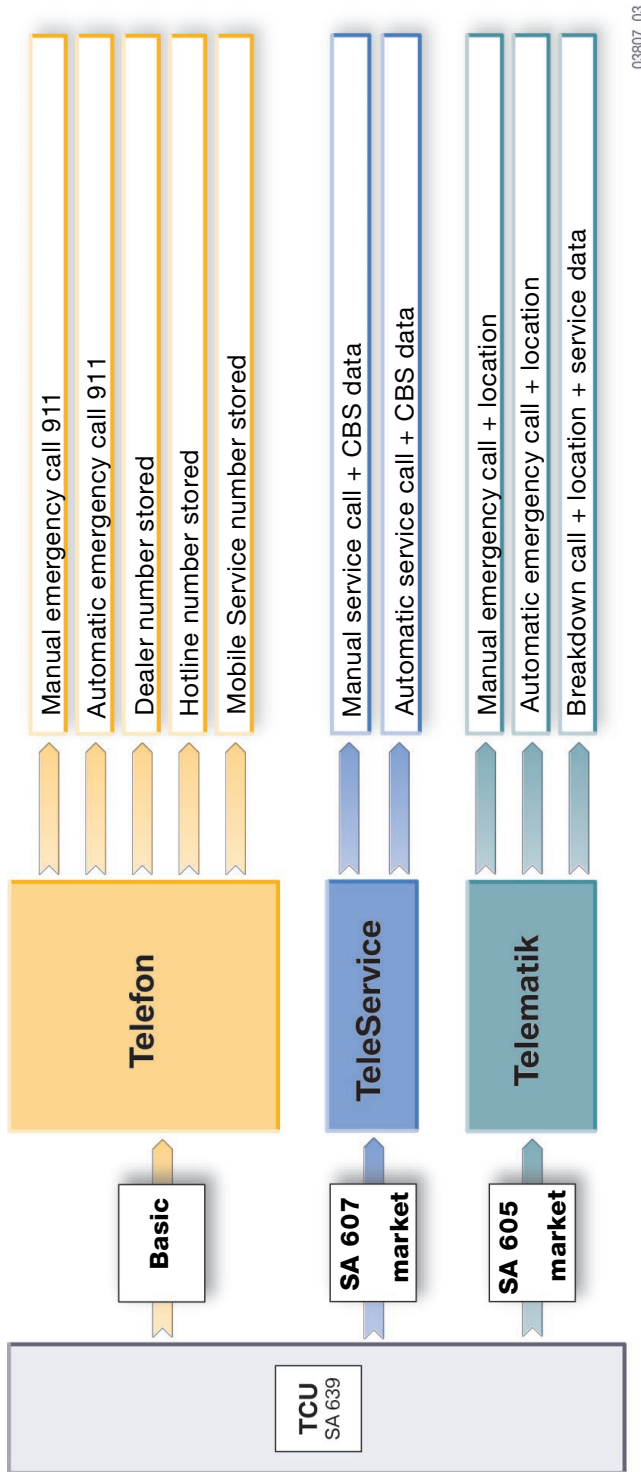

KT-12589

Fig. 42: Overview of functions in US variant

- Telecommunication services with navigation system

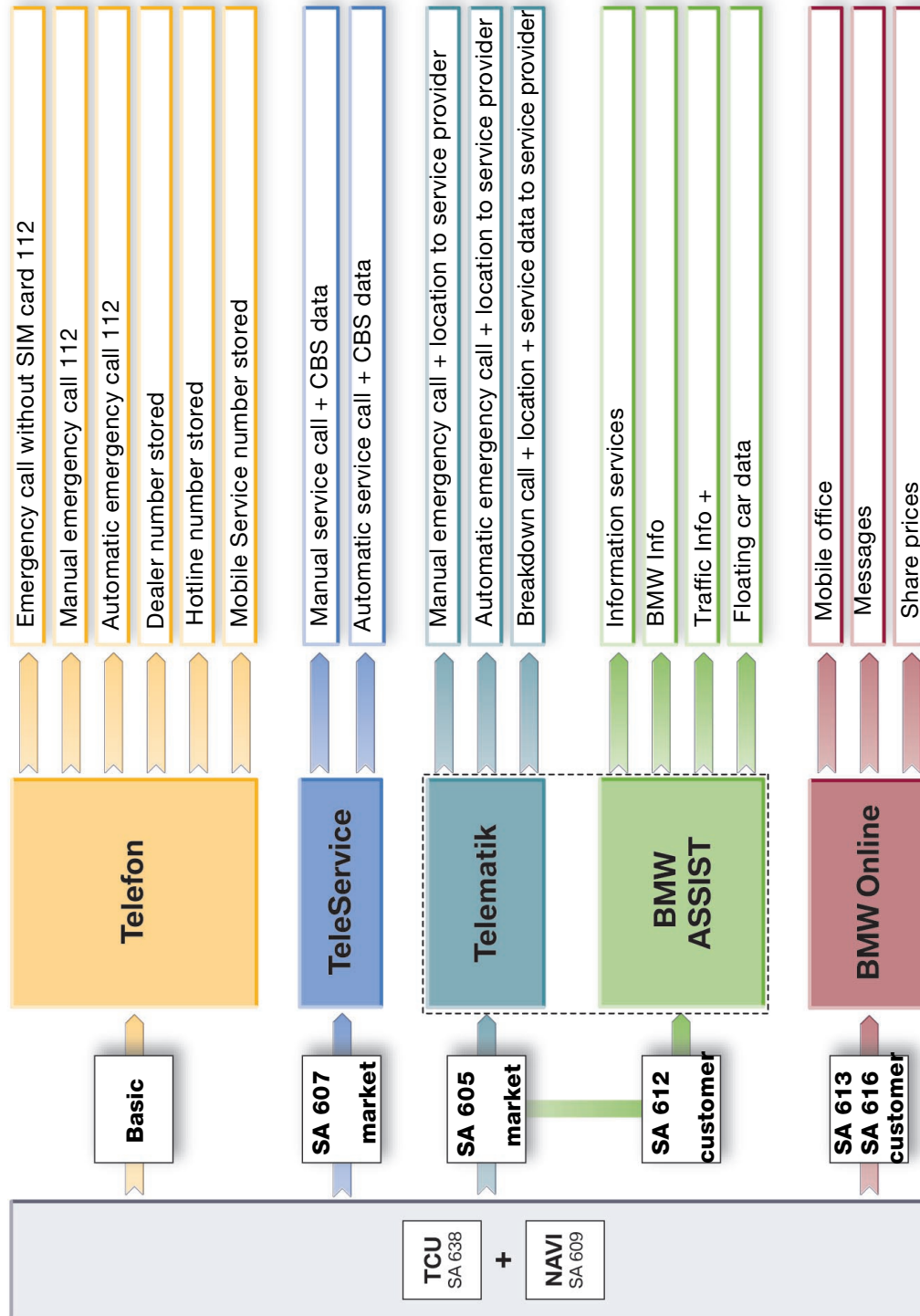

03805\_03

KT-12587

Fig. 43: Overview of possible functions in D/GB



## - TeleService 1

TeleService 1 is the second stage of the condition-based service CBS started in the E65. In the E65, the vehicle data and CBS data were stored in the radio remote control system (radio remote control key). With the aid of the key reader and the service acceptance module 1 (SAM1) it was possible for the service adviser to read out the data and advise the customer.

In the TeleService 1 system, the vehicle data and CBS data are transferred to the dealer by teletransmission in the form of data SMSes.

SA 607 TeleService 1 is not a customer option, i.e. it cannot be ordered by the customer. The SA is country-specific and is ordered by the respective sales department as soon as the prerequisites have been fulfilled in the respective market.

**Note:** When purchasing the vehicle, the TeleService 1 functions are pointed out to the customer. By signing the purchase agreement, the customer consents to the transmission of data from his vehicle to the dealer (data protection).

In service applications, SA 607 TeleService 1 is used to transmit vehicle-specific data in order to gain a precise picture of the specific circumstances, enabling more precise planning for service purposes. This system therefore ensures the workshop capacity is better utilized and the customer gains from more exact scheduling.

TeleService 1 therefore offers the following functions:

- Automatic service call triggered by **C**ondition **B**ased **S**ervice
- Manual service call to the home dealer with service data
- Manual service call to the customer hotline with service data

Which of these functions is implemented in the respective market depends on country-specific circumstances. In Germany, for example, only the automatic service call is used at present.

The service data consist of several binary coded SMSes that are identified by way of coding to establish whether the call is an automatic (A) or a manual (M) service call. In this way, the provider recognizes where the data are to be sent and whether a voice connection to the vehicle needs to be set up.

The following service data are transmitted from the vehicle in connection with a service call:

- Vehicle identification number (VIN)
- Service call identifier (A, M)
- Type code
- Kilometer reading
- Date of first registration
- Date/time
- Colour code
- Upholstery code
- Battery voltage
- Fuel tank content
- Coolant temperature
- CBS information, e.g. maintenance status of brakes, engine oil, etc.

The service data are also transmitted in connection with a breakdown call. The breakdown call, however, is handled by the BMW ASSIST option.

Prior to handing over the vehicle to the customer, the services in the vehicle must be initially enabled via the information menu in the CID.

### **Costs for the customer**

Providing the roaming function is not activated, the customer incurs no costs by sending data packages for TeleService 1. The roaming function is deactivated ex-factory. If the customer wishes to use TeleService 1 abroad, he can do so by activating the roaming function. The roaming costs are added to his/her SIM card.

BMW transfers the costs to the respective subsidiary that also has the benefits from these services.

### **Automatic service call**

The automatic service call is triggered without customer activities. An automatic service call is triggered when the service requirement indicator (SBA) in the instrument cluster changes from green to yellow.

The service data and the CBS data are then sent to the service provider in the form of several data packages. The service provider decodes the data, processes them and transfers them to a BMW database. With the service acceptance module 2 (SAM2), the dealer can access the data specifically stored for him.

At a determined time, the dealer can contact the customer for the purpose of agreeing a date for a service appointment.

### **Manual service call**

When a service call is triggered manually by means of a softkey in the service menu of the CID, not only are the service data transferred to the service partner but a voice connection is also set up. The service partner communicates with the customer to obtain further information.

The data in this case are also accessed using the service acceptance module 2 (SAM2).

### **Implementation of TeleService 1**

Since a specific infrastructure must be created in the respective countries for the purpose of implementing the TeleService 1 concept, TeleService 1 will be realized in the following countries from 2003:

- Germany
- United Kingdom
- USA

TeleService 1 is planned in the following countries:

- Austria
- Switzerland
- France
- Belgium
- Italy
- Spain
- Australia
- South Africa

## **- BMW ASSIST**

If a customer wishes to use the BMW ASSIST functions, he may do so only in connection with a navigation system. The option SA 612 BMW ASSIST requires compulsory coupling with SA 605 Telematics preparation. The emergency call functions for BMW ASSIST are included in the option SA 605.

If a customer orders the options SA 638 Car telephone Professional and a navigation system, he will receive BMW ASSIST automatically free of charge for one year. The customer only needs to apply for the system to be enabled.

The costs are borne by BMW for the first year. After a year, the customer will be requested to decide on the further use of the system. If the customer wishes to continue to use the functions, the costs incurred will be billed on the customer's SIM card. Otherwise the functions will be deactivated automatically.

BMW ASSIST is currently available only in Germany and the United Kingdom.

### **Enabling BMW ASSIST services**

The customer must apply for BMW ASSIST services to be enabled at BMW. The initialization procedure is normally carried out as part of the pre-delivery inspection.

Initialization is carried out as follows:

- The SIM card, specified in the telematics agreement must be inserted
- Press the controller to access the "5th menu"
- Select and confirm "BMW Assist settings"
- Select and confirm "Services status"
- Select and confirm "Enable BMW Assist services"
- The initialization procedure now takes place automatically
- Following successful initialization, the menu "BMW Assist" additionally appears in the main menu



KT-12336

03024\_02

Fig. 44: Initialization menu selection

Index	Description	Index	Description
1	Activate service	3	Activate service status
2	Activate BMW ASSIST settings	4	Display during initialization

The customer can now use the following functions under the "BMW ASSIST" menu:

- Manual emergency call with location information
- Automatic emergency call with location information
- Breakdown call with location information
- Information services
- BMW Info
- V-Info+ (Traffic Information Plus)
- Floating car data (FCD)

### **Telematics preparation**

SA 605 Telematics preparation is not a customer option, i.e. it cannot be ordered by the customer and is the basis for the SA 612 BMW ASSIST. SA 605 depends on the specific equipment and country and is ordered by the respective sales department. A service provider is the prerequisite for implementation in the respective markets.

SA 605 Telematics contains the emergency call functions with location data and is available for all EU states and the USA. The only exceptions are Norway and Switzerland. Automatic emergency call is not permitted in Switzerland for legal reasons.

### **Manual emergency call with location information**

A manual emergency call button is located in the front roof console. A flap cover protects the emergency call button from being pressed inadvertently. In the case of emergency, the customer can open the flap cover and must press the button for at least 2 seconds.

If active, a pop-up menu appears in the CID with a countdown bar that indicates the remaining time. The emergency call can be cancelled within 5 seconds. This only applies to EU vehicles. In US vehicles once activated, the emergency call can no longer be cancelled.

The emergency call number of the service provider is dialled on activation of the emergency call button. The indicator lamp in the emergency call button is active during this time. When the service provider accepts the emergency call and a voice connection is set up, the indicator lamp then flashes during this period of time. The TCU sends the corresponding data together with the location coordinates to the service provider.

The country-specific emergency call number is dialled (112) if no connection to the service provider is established after about 2 minutes.

### **Automatic emergency call with location information**

In the event of an accident with corresponding crash severity, the SGM sends a crash telegram via a serial line to the TCU. In turn, the TCU sets up a connection with the emergency call number of the service provider.

The service provider attempts to establish a voice connection with the occupants in order to obtain further information about the accident (accident severity, number of injured) so that appropriate rescue measures can be initiated. The TCU also sends data with location coordinates to the service provider.

The country-specific emergency call number is dialled (112) if no connection to the service provider is established after about 2 minutes.

### **Breakdown call with location information and service data**

SA 612 BMW ASSIST contains a breakdown call facility. The BMW ASSIST menu in the central information display features a "BMW Mobile Service" button.

The TCU attempts to set up a voice connection with the service provider. At the same time, not only the location data are sent but also the vehicle service data. In this way, the mobile service obtains a more precise picture of the vehicle status and can implement the corresponding measures.

If no voice connection can be set up with the service provider, the stored Mobile Service call number of the BMW Group is selected.



### **Information services**

The BMW information service is a call centre of a service provider which the customer can call and obtain information. Corresponding to location, the BMW information service currently offers information on:

- Hotels
- Restaurants
- Filling stations
- Places of interest
- Events, etc.

Via SMS, the customer receives information from the service provider together with navigation coordinates of the destination as well as the necessary telephone numbers. The customer can also be connected directly by telephone on request. The target coordinates can be adopted in the navigation system by the push of a button. The address and telephone number are shown in the menu of the CID.

## **BMW Info**

BMW Info provides the customer with information on current campaigns and events at BMW. The customer is informed of technical campaigns concerning his/her vehicle or of special sales campaigns, e.g. winter tyres, or marketing information.

This information is sent via SMS. No voice connection is set up. The service provider provides the customer with a mailbox.

The customer receives a message on the central information display indicating that he/she has messages in his/her mailbox. These messages are downloaded in the form of SMSes from the mailbox to the vehicle. For this purpose, the TCU features a memory for the SMSes. A maximum of 10 SMSes can be loaded from the mailbox to the vehicle.

Following successful download of the SMSes from the mailbox, the messages are deleted at the service provider. The SMSes are shown in a list in the vehicle. The list is arranged according to the date with the latest message at the top. No further messages can be downloaded when the memory is full. The button for downloading messages is deactivated.

The customer can now edit the messages. The following options are available:

- Reply to SMS
- Delete SMS
- Accept as possible navigation destination
- Call number

## **V-Info+**

In addition to the traffic information transmitted by the radio stations, BMW ASSIST customers can receive specific information on the current traffic situation.

The additional information is made available by a service provider. The TCU informs the service provider of the destination planned in the navigation system. The service provider provides explicit information with regard to possible hold-ups on this route. This information could include, for example:

- Roadworks
- Accidents
- Traffic queues with information on the length and approximate duration
- Traffic volume
- Recommended diversions

The service provider receives this additional information from sensors on motorway bridges that monitor the traffic flow and from vehicles equipped with floating car data (FCD).

## **Floating car data**

Floating car data (FCD) are traffic information collected by "floating cars" (vehicles in the traffic flow). On request, BMW ASSIST customers can use their vehicles in the FCD system and transmit data.

In this case, the own vehicle serves as a sensor for the traffic flow. The navigation coordinates, the road speed as well as the time are sent encrypted by SMS to the service provider. The service provider does not know from what vehicle the data was transmitted (data protection). Here, the data are collected and are used in the form of V-Info+ to assist BMW ASSIST customers.

Data transmission is free of charge for the customer. The only exception is when the customer uses a prepaid card.

## **- Online services**

The customer can use online services in connection with SA 613 Internet-based services, SA 616 Online platform and the car communication computer.

SA 616 Online platform contains the HW/SW module (browser) and facilitates technical implementation in the vehicle.

SA 613 Internet-based services is the application and enables the customer to access the BMW portal. Selected Internet-based services are offered to the customer on the BMW portal. For example, the following services could be made available to the customer:

- Checking share prices and obtaining stock market tips
- Calling up flight schedules and planning journey routes
- Booking hotel rooms and making restaurant reservations
- Ordering theater and cinema tickets
- Receiving current information and sports events
- Receiving and sending e-mails
- Banking
- Online shopping
- Using information services, e.g. Yellow Pages

The services offered are defined by the respective market and are updated and/or expanded dynamically. The customer has access to the BMW online services via his/her own BMW Internet portal. The customer has the option of accessing the portal from his/her home PC, from his/her WAP mobile phone or from the vehicle.

Unrestricted surfing on the Internet is not possible for safety reasons. With a firewall, filter functions and access codes, the special safety concept of the BMW online services and of the BMW portal protect the vehicle, its software and all data from unauthorized access and viruses.

The functionalities are essentially identical to those of the E65/E66. The same is true for the user interface as the same icons are used. The only difference is in the way the pages are changed. In the E65/66 the pages are turned while in the E60/E63 they are scrolled.