

Service.



ESP

Electronic Stability Programme

Design and function

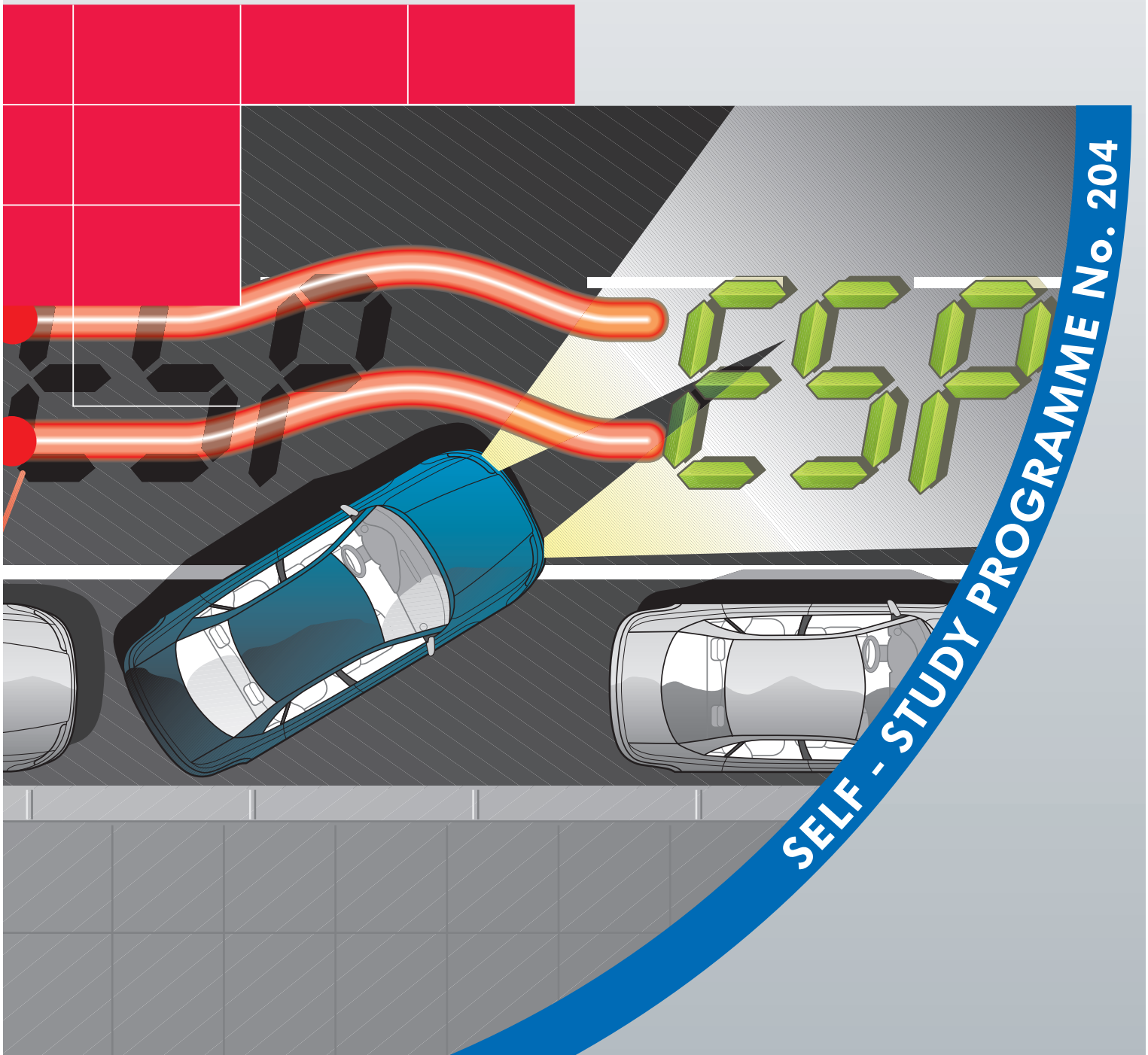

SELF - STUDY PROGRAMME No. 204

ESP is the abbreviation for “Electronic stability programme”.

The system's task is to assist the driver in demanding driving situations, e.g. if a wild animal suddenly runs across path of vehicle, and also to compensate for overreaction on the part of the driver and to prevent loss of vehicle stability.

However, ESP is not intended for speed manics to try and defy the laws of physics.

A responsible driving style adapted to the prevailing road and traffic conditions is therefore still essential.

In the course of this booklet, we will explain how ESP is based on the proven anti-lock braking system (ABS) and its related systems - TCS, EDL, EBD and EBC - and we will describe the various versions of ESP which we use in our vehicles.



204_095

NEW



Important Note



The Self-Study Programme is not a Workshop Manual.

Please always refer to the relevant Service Literature for all inspection, adjustment and repair instructions.



Introduction	4
Basic physical principles	7
Driving dynamic control	9
Overview	12
BOSCH	14
System overview	14
Design and function of ESP	16
Functional diagram	32
Self-diagnosis	34
ITT Automotive	36
System overview	36
Design and function of ESP	38
Functional diagram	56
Self-diagnosis	58
Service	60



Introduction

Retrospective

Ongoing technical advances in the motor vehicle industry have seen vehicles with increasing performance and power output come onto the market. Even in the early days, designers were confronted with the question of how to keep this technology manageable for the average driver. In other words: What systems would be required to ensure maximum braking safety and assist the driver?

Purely mechanical precursors to the modern-day anti-lock braking system were first conceived as long ago as the 1920s and 1940s. However, these systems were not suited to the task in hand because they were too slow.

The electronics revolution in the 1960s made anti-lock braking systems feasible. Such systems have become more and more efficient with the further development of digital technology. Today, we regard not only ABS, but also systems such as EDL, EBD, TCS and EBC, as everyday technology. Today's state of the art is reflected in ESP, which is now ready for production. However, our engineers are already thinking one step further.

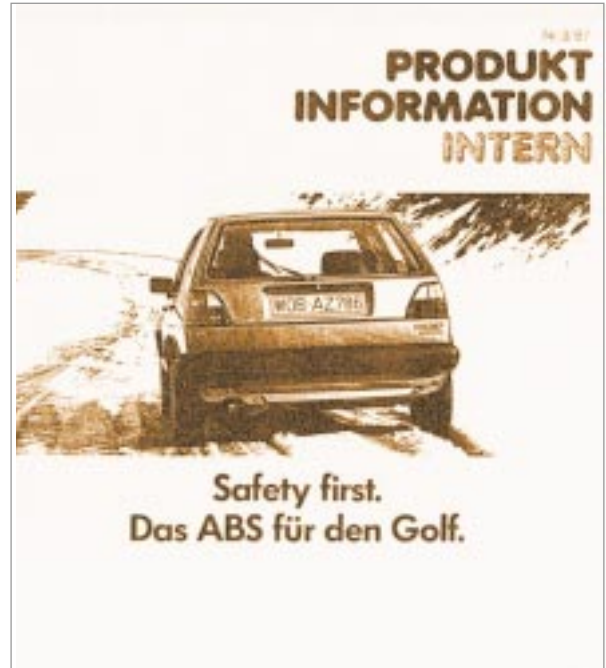

204_069

What does ESP do?

The electronic stability programme is one of the vehicle's active safety features.

It is also known as a "driving dynamic control system".

Expressed in simple terms, ESP is an anti-skid programme.

It recognises when the vehicle is in danger of skidding and compensates when the vehicle breaks out.

Plus-points:

- ESP is not an independent system. In fact it is based on other traction control systems. That is why it also includes the performance features of these systems.
- It relieves the burden on the driver.
- The vehicle remains manageable.
- It reduces the accident risk if the driver overreacts.

Brevity is the soul of wit



However, since there are so many vehicle systems that sound alike, abbreviations can be confusing. That is why we have summarised the most commonly used concepts for you below.

ABS

Anti-lock Braking System

This system prevents the wheels from locking while braking. Despite the system's powerful braking effect, track stability and steerability are re-tained.

TCS

Traction Control System

This system prevents the driven wheels from spinning, e.g. on ice or gravel, by intervening in the brake and engine management systems.

EBD

Electronic Brake Pressure Distribution

This system prevents overbraking of the rear wheels before ABS takes effect or if ABS is unavailable, due to specific fault states.

EDL

Electronic Differential Lock

This system makes it possible to drive away on road surfaces where each wheel has a different degree of traction by braking the wheel which is spinning.

ESP

Electronic Stability Programme

This system prevents the vehicle from skidding by selectively intervening in the brake and engine management systems. The following abbreviations are used also:

- ASMS (**A**utomatic **S**tability **M**anagement **S**ystem),
- DSC (**D**ynamic **S**tability **C**ontrol),
- DDC (**D**riving **D**ynamic **C**ontrol),
- VSA (**V**ehicle **S**tability **A**ssist) and
- VSC (**V**ehicle **S**tability **C**ontrol).

EBC

Engine Braking Control

This system prevents the driven wheels from locking due to the engine braking effect when the accelerator pedal is released suddenly or when the vehicle is braked with a gear engaged.

Introduction



These two different systems used are within the Group for various vehicle types.

BOSCH	ITT AUTOMOTIVE
Audi A8	Golf '98
Audi A6	Audi A3, Audi TT
Audi A4	Skoda Oktavia
Passat '97	New Beetle
	Seat Toledo

To prevent skidding, a driving dynamic control system such as ESP must be able to control brake activation within a fraction of a second. The return flow pump for the anti-lock braking system produces the pressure required. To improve the delivery rate of the pump, there must be sufficient pre-pressure provided on the suction side.

The fundamental difference between the systems made by BOSCH and ITT Automotive is how this pre-pressure is built up.

BOSCH

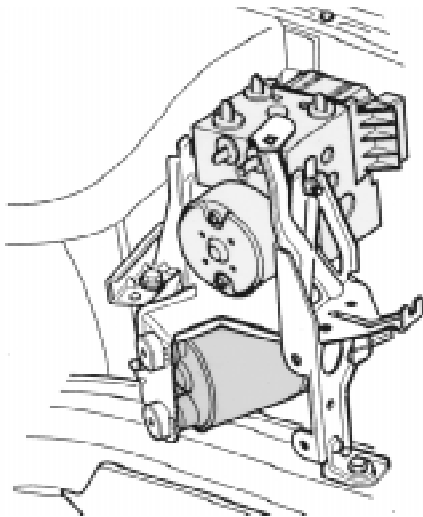

204_085

In the Bosch system, the pre-pressure is generated by a charge pump. This pump is known as the hydraulic pump for driving dynamic control and is attached to a common bracket located below the hydraulic unit. The ESP control unit and the hydraulic unit are separated.

ITT Automotive



204_086

In the ITT system, the pre-pressure is generated by an active brake servo. It is also known as a booster. The hydraulic unit and the control unit form a single module.

Basic physical principles

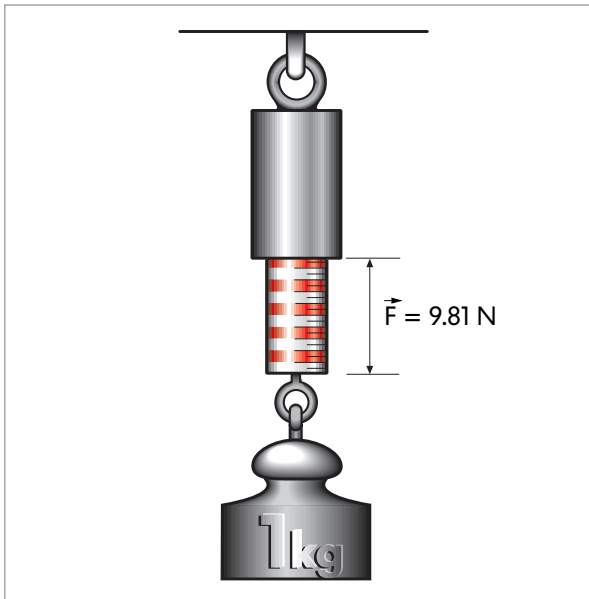

204_002

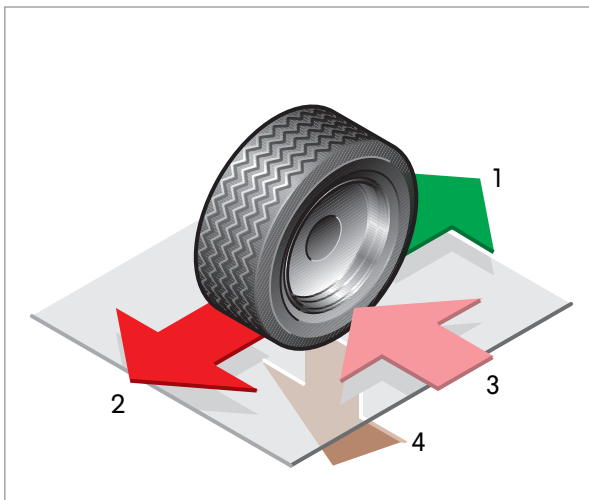

204_003

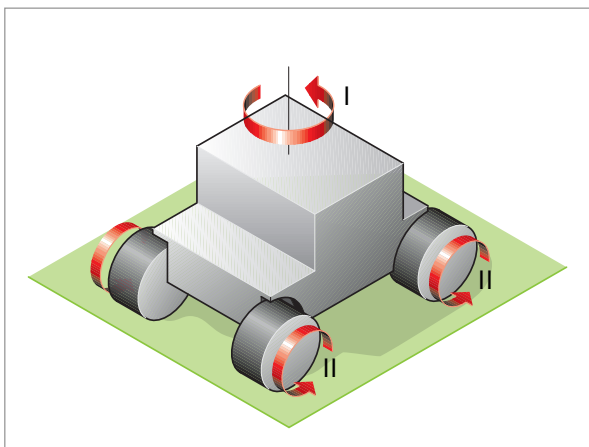

204_019

Forces and moments

A body is subjected to different forces and moments. If the total of the forces and moments acting on the body equals zero, the body is at rest. If this total does not equal zero, the body is moving in the direction of the resultant force of this total.

The most widely known force to man is that of gravity. The force of gravity acts in the direction of the centre of the earth.

If you suspend a 1 kilogram weight from a spring balance in order to measure the forces that occur, the balance will give a reading of 9.81 Newtons for the force of gravity.

Additional forces which act on a vehicle are:

- Tractive force (1)
- Brake pressure (2) which counteracts tractive force
- Lateral forces (3) which preserve the vehicle's steerability and
- Adhesion forces (4) resulting from friction and gravity, among other things.

Vehicles are also subjected to the following forces:

- Yaw moments (I) which try to rotate the vehicle about its vertical axis as well as
- Wheel moments and moments of inertia (II) which try to retain the direction in which the vehicle is moving
- Plus other forces such as aerodynamic drag.



Basic physical principles

Interaction between some of these forces can be described using of the Kamm friction circle. The radius of the circle is defined by the adhesion force between the road surface and the tyres. In other words, the lower the adhesion force, the smaller the radius (a): the higher the adhesion force, the larger the radius (b).

The basis of the friction circle is a forceparallelogram comprising lateral force (S), brake power or tractive force (B) and a resultant total force (G).

As long as the total force lies within the circle, the vehicle is in a stable state (I). If the total force exceeds the circle, the vehicle is no longer controllable (II).

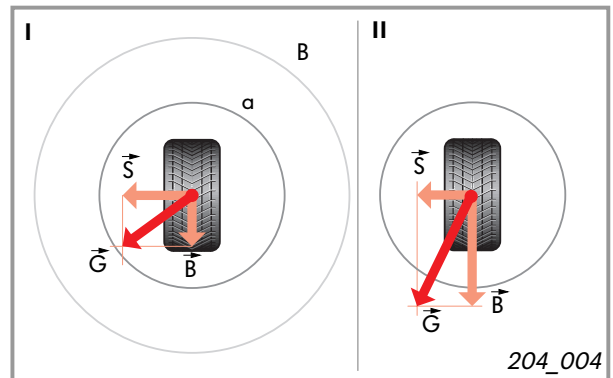

Consider the inter-relationships between the forces at play:

1. The magnitudes the brake pressure and lateral force are such that the total force lies within the circle. The vehicle is steerable without any problem.

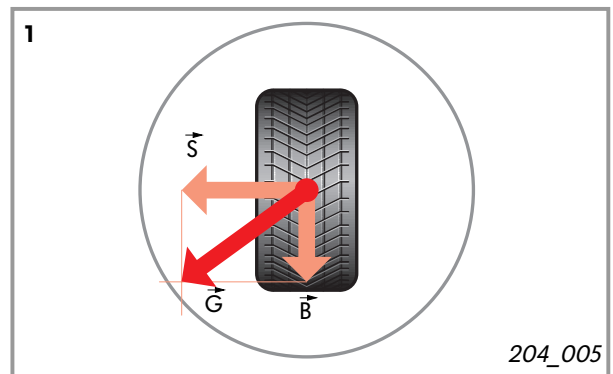

2. Now brake pressure is increased. Lateral force is low.

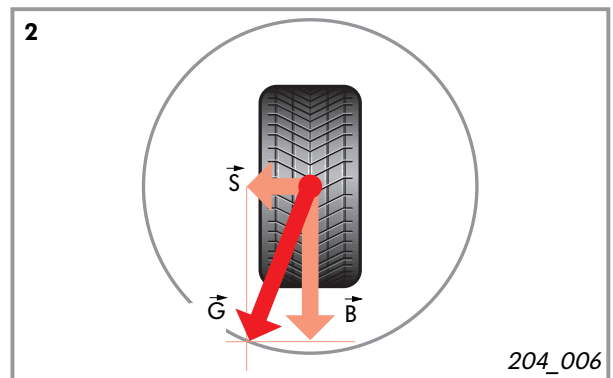

3. Total force equals brake pressure. The wheel locks up. The vehicle can no longer be controlled since there are no lateral forces. A similar relationship exists between input power and lateral force. If the lateral forces are zero because input power is fully utilised, the driven wheels will spin.

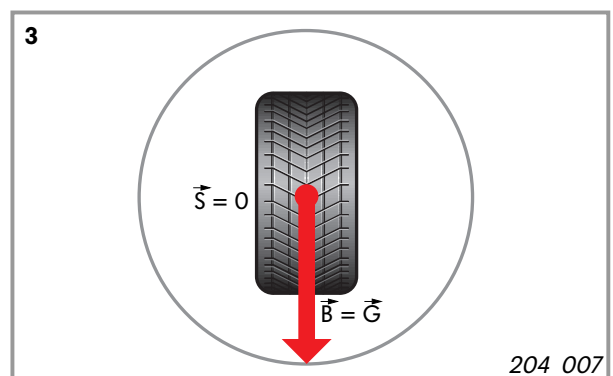

Driving dynamic control

Control process

Before ESP can respond to a critical driving situation, it must answer two questions:

a - In what direction is the driver steering?

b - In what direction is the vehicle moving?

The system obtains the answer to the first question from the steering angle sensor (1) and the speed sensors at the wheels (2).

The answer to the second question is supplied by measuring the yaw rate (3) and lateral acceleration (4).

If the information received provides two different answers to questions a and b, ESP assumes that a critical situation can occur and that intervention is necessary.

A critical situation may manifest itself in two different types of behaviour of the vehicle:

I. The vehicle threatens to understeer.
By selectively activating the rear brake on the inside of the corner and intervening in the engine and gearbox management systems, ESP prevents the vehicle from overshooting the corner.

II. The vehicle threatens to oversteer.
By selectively activating the front brake on the outside of the corner and intervening in the engine and gearbox management systems, ESP prevents the vehicle from skidding.

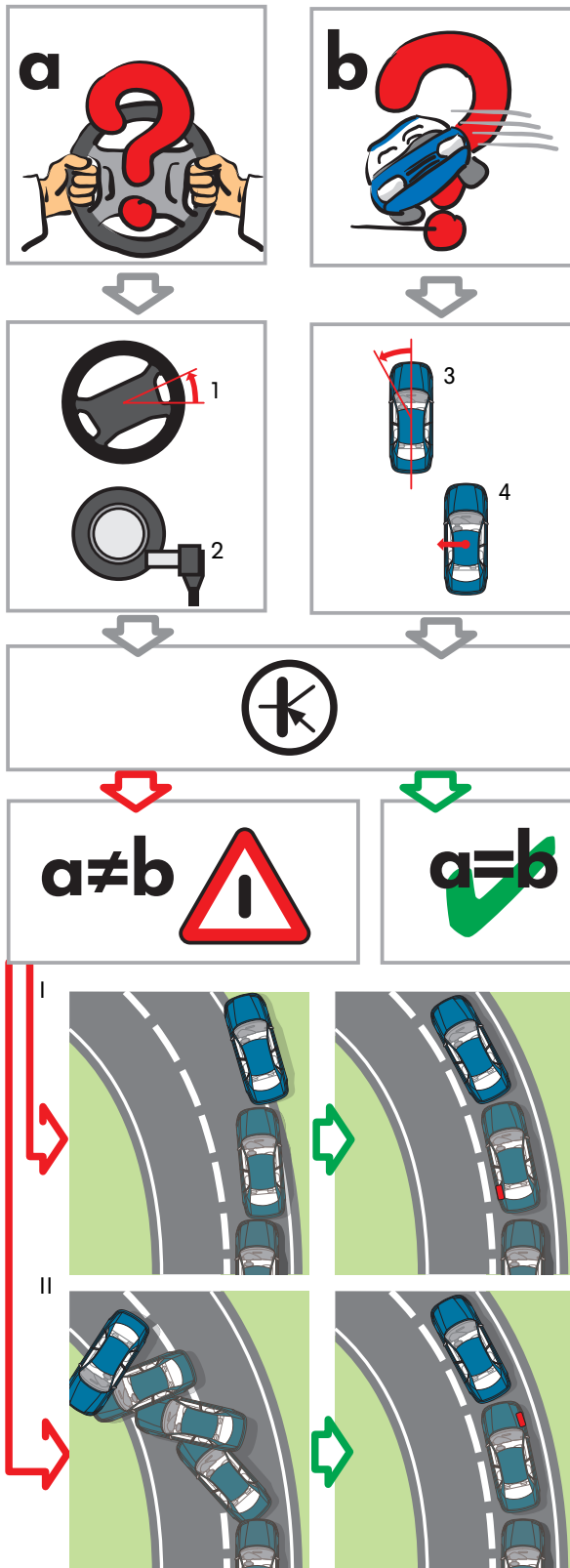

204_008



Driving dynamic control

As you can see, ESP can counteract both oversteer and understeer. For this purpose, it is also necessary to initiate a change of direction without direct intervention in the steering.

The basic principle is the same as for tracked vehicles.

When a bulldozer wants to negotiate a left-hand bend, the track on the inside of the corner is braked and the outer track is accelerated.

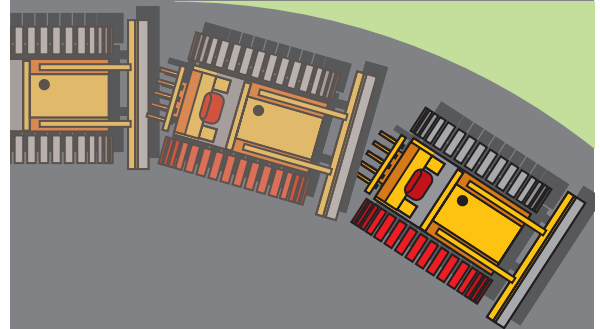

204_009

To return to the original direction of travel, the track which was previously on the inside of the corner and now on the outside of the corner is accelerated and the other track is braked.

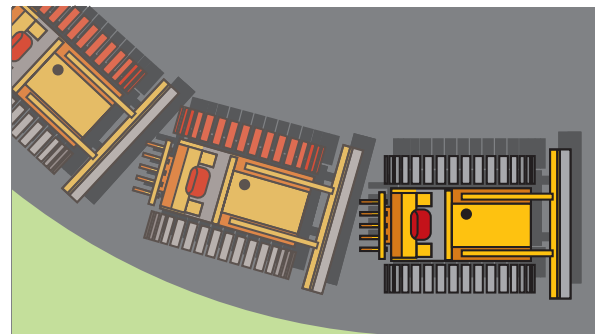

204_010

ESP intervenes along much the same lines. Here is an example of how such a situation is handled by a vehicle **without ESP**.

The vehicle must avoid an obstacle which suddenly appears. At first, the driver steers very quickly to the left and to then immediately to the right.

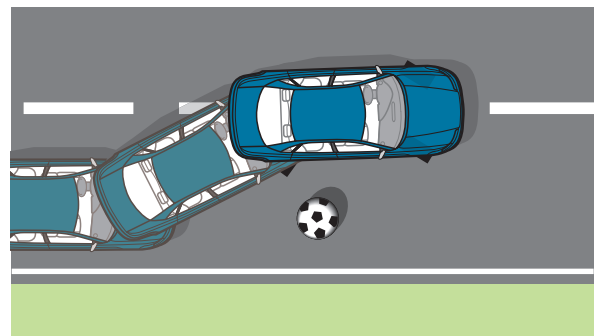

204_011

The vehicle swerves due to the driver's steering wheel movements and the rear end breaks away. The driver is no longer able to control the resulting rotation about the vertical axis.

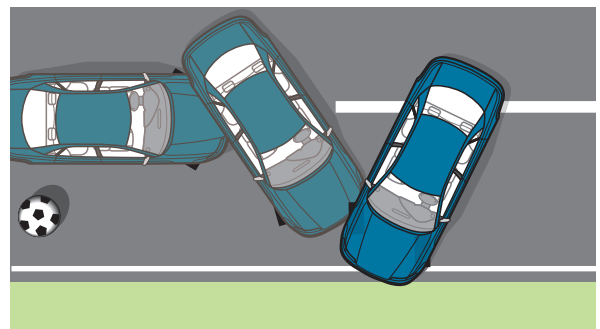

204_012

Now let us observe how a vehicle handles the same situation **with ESP**.

The vehicle attempts to avoid the obstacle. From the data provided by the sensors, ESP recognises that the vehicle is losing stability. The system calculates its counteraction measures: ESP brakes the left-hand rear wheel. This promotes the turning motion of the vehicle. The lateral force acting on the front wheels is retained.

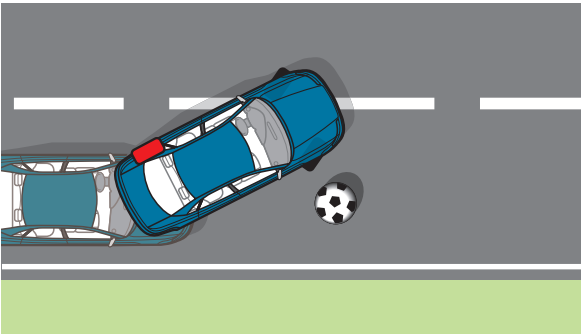

204_013

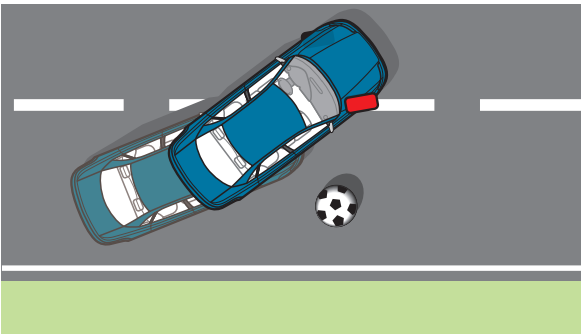

204_014

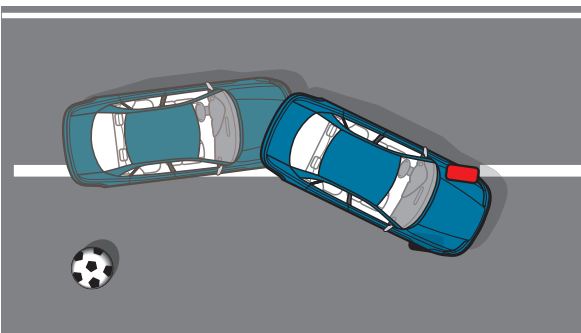

204_016

As the vehicle swerves to the left, the driver steers to the right. To help the driver steer into the over-steer, the front right wheel is braked. The rear wheels roll freely in order to ensure an optimal build-up of lateral forces acting on the rear axle.

The preceding lane change can cause the vehicle to roll about its vertical axis. To prevent the rear end from breaking away, the front left wheel is braked. In highly critical situations, the wheel may be braked very heavily in order to limit the build-up of lateral forces on the front axle (Kamm circle).

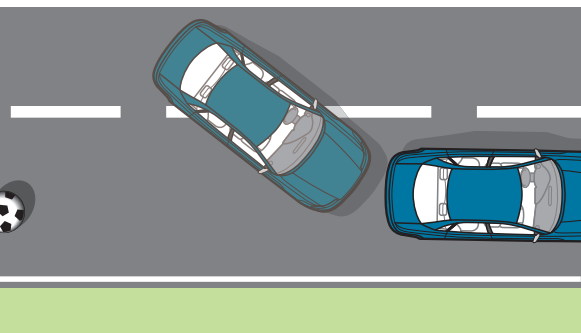

204_017

Once all instable operating states have been corrected, ESP ends its corrective intervention.

Overview

The system and its components

As mentioned already, the electronic stability programme is based on the proven traction control system.

However, it has several key additional features:

- The system can recognise and compensate for instable vehicle operating states at an early stage, such as skidding.

For this purpose, several additional components are required.

Before we explain ESP in greater detail, here is an overview of these components.

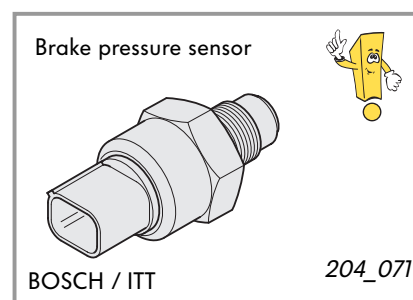
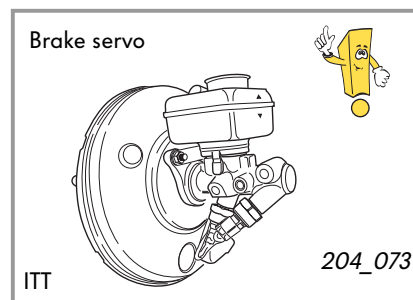
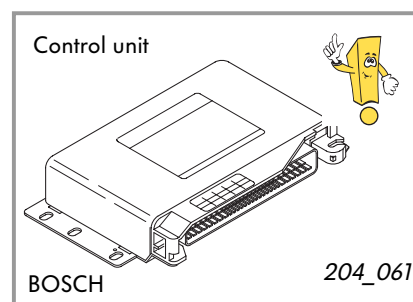

Two makes of ESP system are fitted to VOLKSWAGEN vehicles. One system is supplied by BOSCH and the other by ITT Automotive. Even though both systems have identical tasks and basic principles, they differ from one another in their component parts. When ordering spare parts, you should note the system on which you are working.

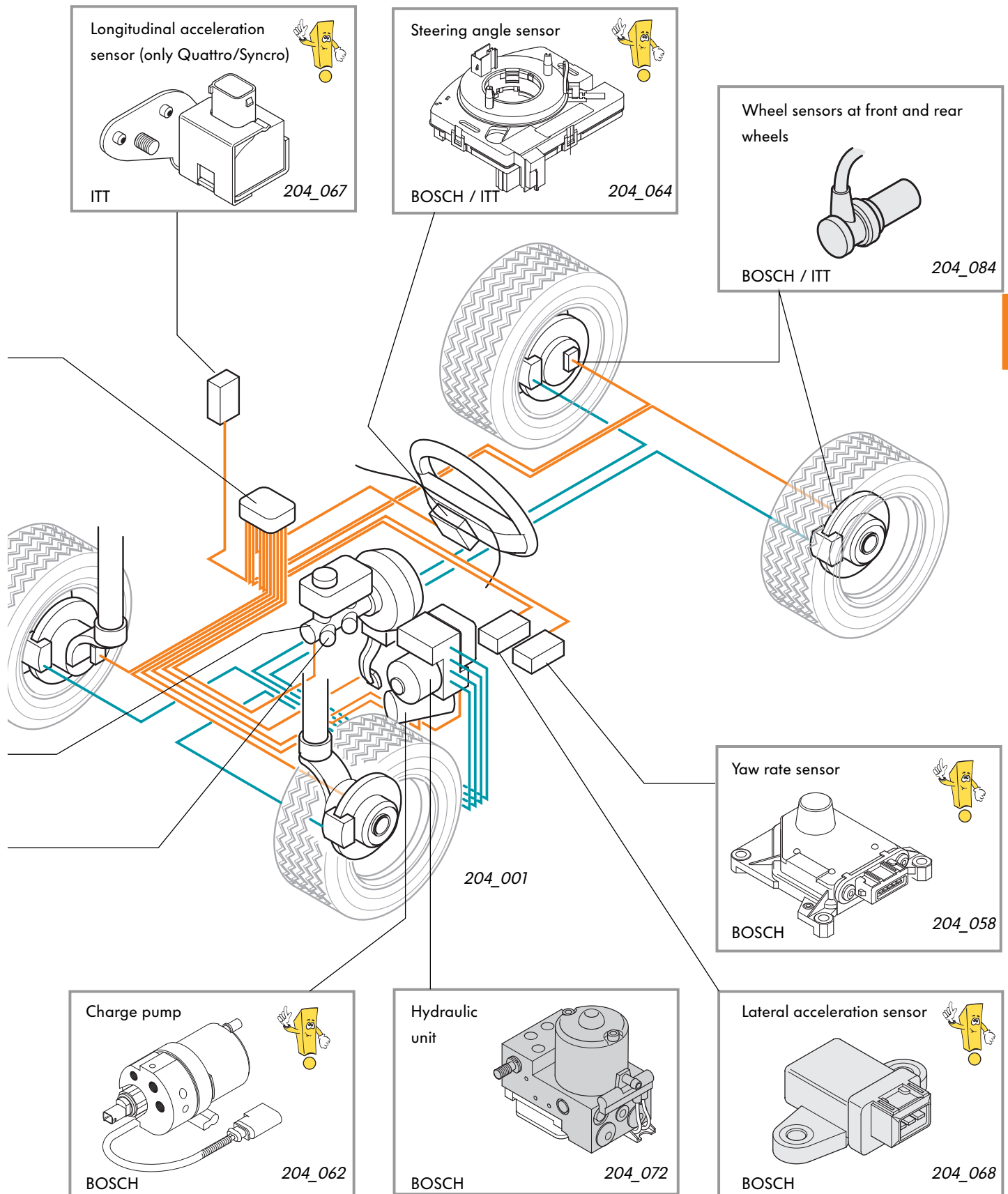

System overview

BOSCH

Probe for TCS/ESP **E256**

Brake light switch **F**

Brake pedal switch **F47**

speed sensors
rear right **G44**
front right **G45**
rear left **G46**
front left **G47**

Steering angle sender **G85**

Lateral acceleration sender **G200**

Brake pressure sender **G201**

Yaw rate sender **G202**,
in footwell on front left in front of central control
system for convenience system

Auxiliary signals

Engine management

Gearbox management system

Sensors

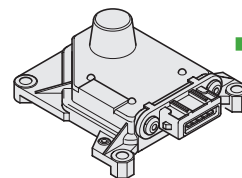
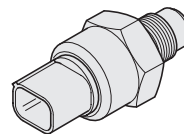
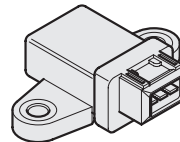
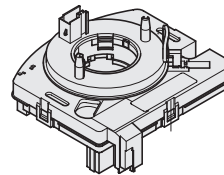
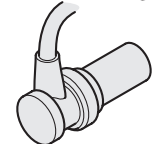
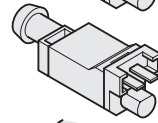
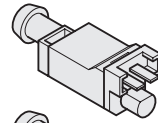
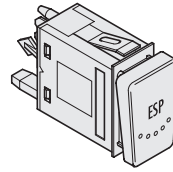

ABS control unit with
EDL/TCS/ESP **J104**,
in footwell on front
right at engine
bulkhead

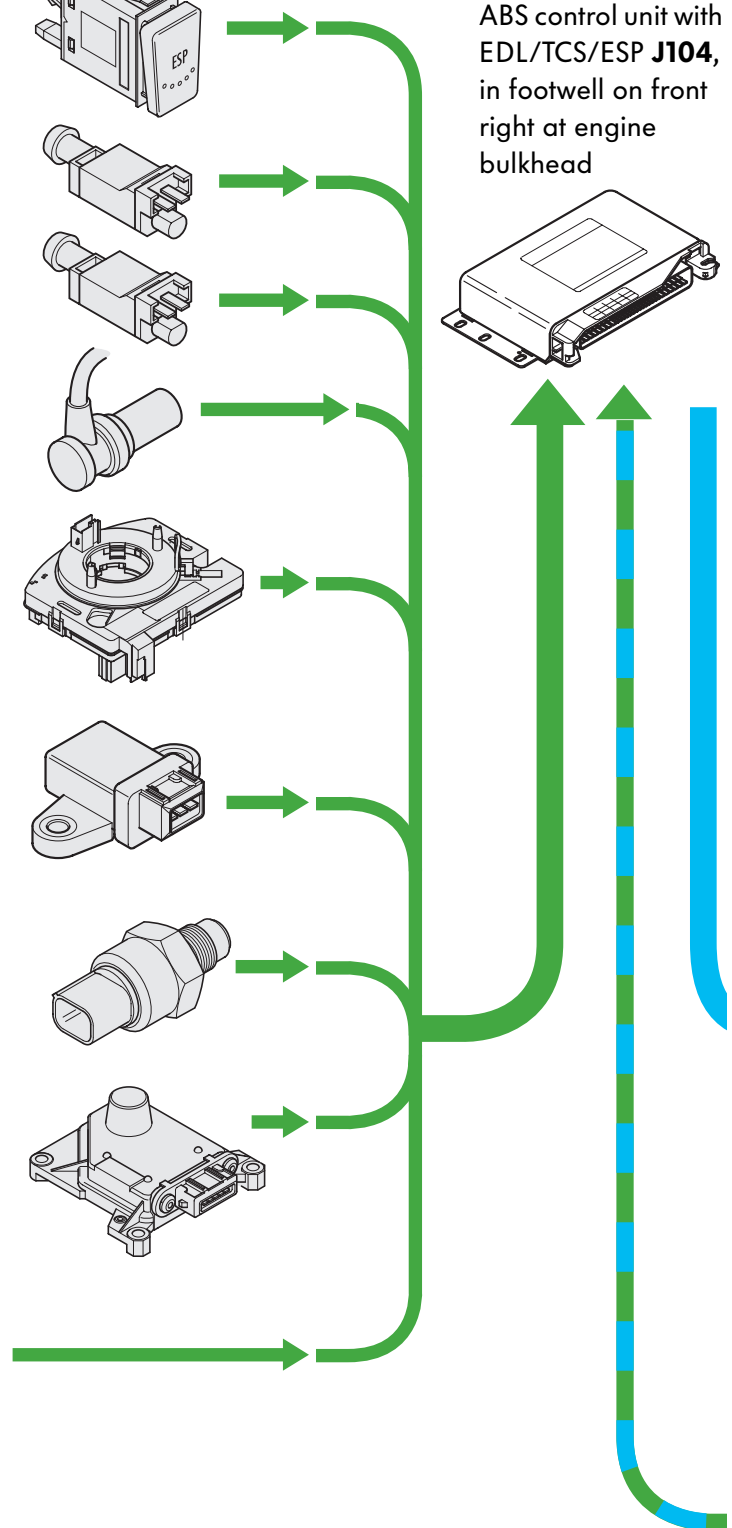
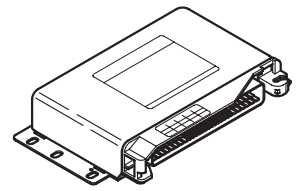

Actuators

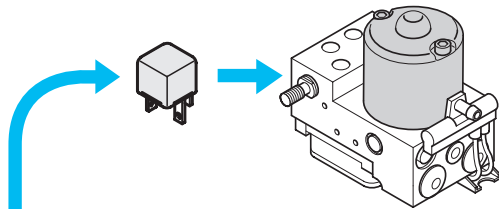

Return flow pump relay - ABS **J105**,
in protective housing for control units,
in engine compartment on front left

Return flow pump for ABS **V39**

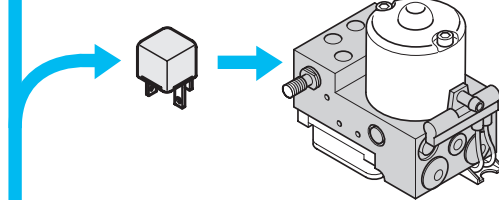

Solenoid valve relay - ABS **J106**,
in protective housing for control units,
in engine compartment on front left

ABS intake valves **N99, N101, N133, N134**

ABS exhaust valves **N100, N102, N135, N136**

Driving dynamic control valve -1- **N225**

Driving dynamic control valve -2- **N226**

Driving dynamic control high-pressure valve -1-
N227

Driving dynamic control high-pressure valve -2-
N228

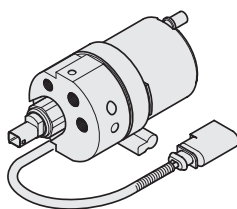

Hydraulic pump for driving dynamic control **V156**

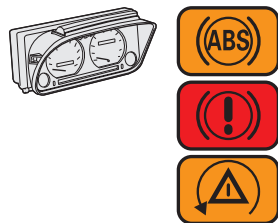

Control unit for display unit in
dash panel insert **J285**

ABS warning lamp **K47**

Warning lamp for brake system **K118**

TCS/ESP warning lamp **K155**

Auxiliary signals

Engine management system

Gearbox management system

Navigation management system

Diagnosis plug connection

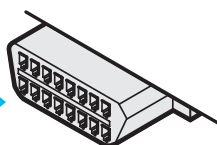

204_087



Design and function of ESP

Control cycle

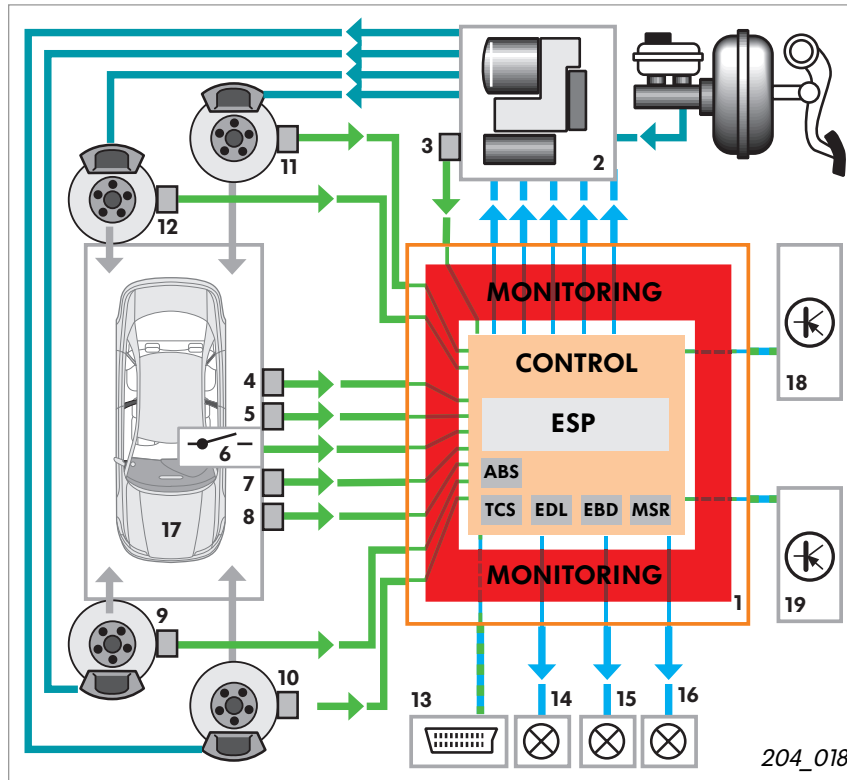

- 1 ABS control unit with EDL/TCS/ESP
- 2 Hydraulic unit with charge pump
- 3 Brake pressure sender
- 4 Lateral acceleration sender
- 5 Yaw rate sender
- 6 Button for TCS/ESP
- 7 Steering angle sender
- 8 Brake light switch
- 9-12 Speed sensor
- 13 Diagnosis wire
- 14 Warning lamp for brake system
- 15 ABS warning lamp
- 16 TCS/ESP warning lamp
- 17 Vehicle and driver behaviour
- 18 Intervention in engine management
- 19 Intervention in gearbox control unit (vehicles with automatic gearbox only)

The speed sensors provide a continuous stream of data on speeds for each wheel.

The steering angle sensor is the only sensor which supplies data directly via the CANbus to the control unit. The control unit calculates the desired steering direction and the required handling performance of the vehicle from both sets of information.

The lateral acceleration sensor signals to the control unit when the vehicle breaks away to the side, and the yaw rate sensor signals when the vehicle begins to skid. The control unit calculates the actual state of the vehicle from these two sets of information.

If the nominal value and actual value do not match, ESP performs corrective intervention calculations.

ESP decides:

- what wheel to brake or accelerate and to what extent,
- whether engine torque is reduced and
- whether the gearbox control unit is activated on vehicles with automatic gearbox.

The system then checks to see if intervention was successful from the data it receives from the sensors.

If this is the case, ESP ends intervention and continues to monitor the vehicle's handling characteristics.

If this is not the case, the intervention cycle is repeated.

When corrective intervention is taking place, this is indicated to the driver by the flashing ESP lamp.

ABS control unit with EDL/TCS/ESP J104

In the Bosch version, the control unit and the hydraulic unit are separated. The control unit is located on the right in the front footwell.

Design and function

The ABS control unit comprises a high-performance microcomputer.

Since a high level of fail-safety is required, the system has two processing units as well as its own voltage monitoring device and a diagnosis interface.

The two processing units utilise identical software for information processing and monitoring one another.

Dual-processor systems of this type have what is known as active redundancy.

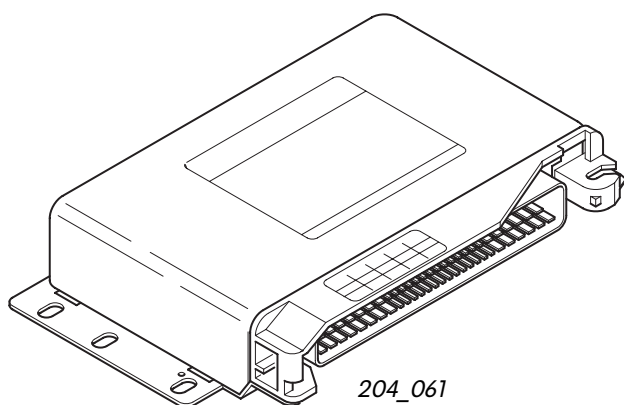

Electric circuit

The control unit J104 obtains its power supply via the positive connection in the dash panel wiring loom.

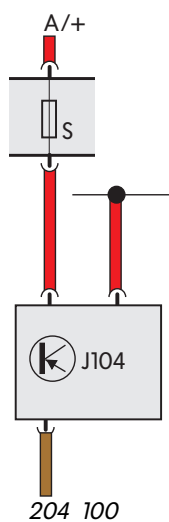

Effects of failure

In the unlikely event of the control unit failing, the driver will only have use of the standard brake system without ABS, EBS, TCS and ESP.

Self-diagnosis

The following faults are detected:
Control unit defective
Power supply failure

Design and function of ESP

Steering angle sender G85

is mounted on the steering column between the steering column switch and the steering wheel. The centring ring with slip ring for the airbag is integrated in the steering angle sender and located on the base of the steering angle sender.

Task

The sender transfers the steering wheel lock angle to the ABS control unit with EDL/TCS/ESP. An angle of $\pm 720^\circ$ corresponds to four full turns of the steering wheel.

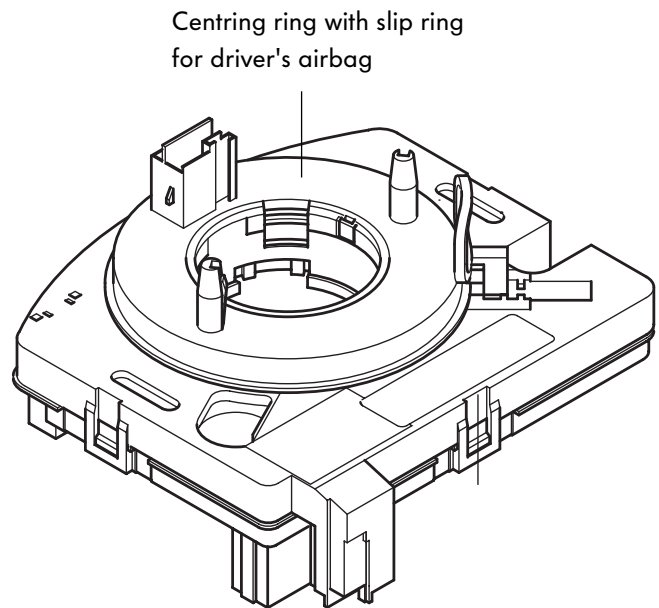

204_064

Effects of failure

Without the information supplied by the steering angle sensor, ESP would be unable to determine the desired direction of travel. The ESP function fails.

Self-diagnosis

After replacing the control unit or the sensor, the zero position must be re-calibrated.

- Steering angle sender - no communication
- Wrong setting
- Mechanical fault
- Defective
- Implausible signal

Electric circuit

G85 is the only sensor of the ESP system which transfers information direct via CANbus to the control unit. After turning on the ignition, the sensor initialises itself as soon as the steering wheel has been rotated through an angle of 4.5° . This is equivalent to a turning movement of approx. 1.5 cm.

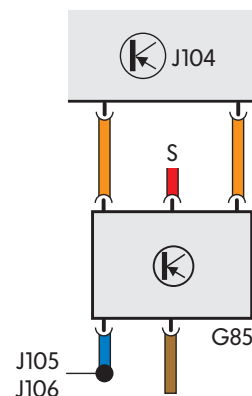

204_101



Faults can occur if the track has become maladjusted. Make sure that the sensor is connected securely to the steering wheel.

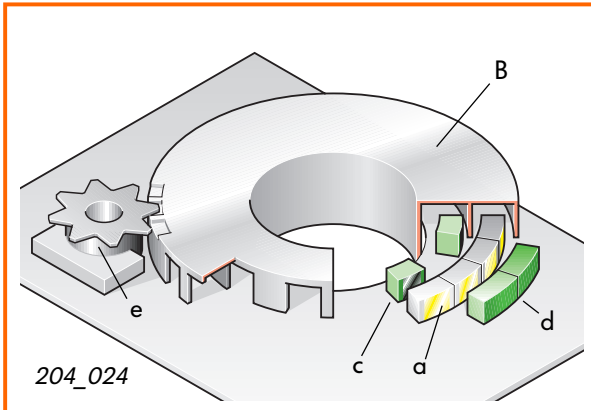

Design

The angle is measured using the principle of the light barrier.

The basic components are:

- a light source (a)
- an encoding disc (b)
- optical sensors (c+d) and
- a counter (e) for full revolutions

The encoding disc comprises two rings: the absolute ring and the incremental ring. Both rings are scanned by two sensors each.

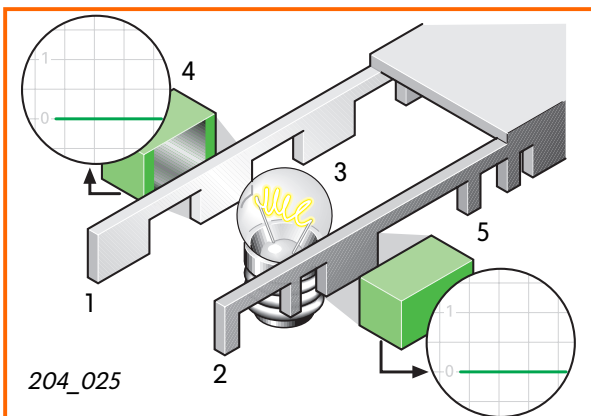

Function

We can simplify the setup by arranging an incremental hole template (1) and an absolute hole template (2) side by side. The light source (3) is positioned in between the hole templates. The optical sensors (4+5) are located on the outside.

Light impinging on a sensor through a gap generates a signal voltage. If the light source is covered, the voltage breaks down again.

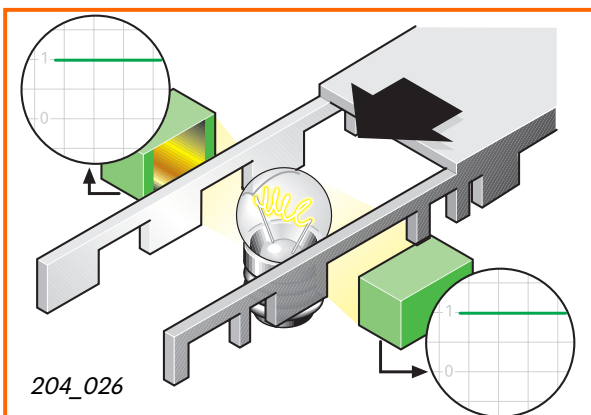

Moving the hole templates produces two different voltage sequences. The incremental sensor supplies a uniform signal, since the gaps follow each other at regular intervals. The absolute sensor generates an irregular signal, since light passes through the gaps in the template at irregular intervals. By comparing both signals, the system can calculate how far the hole template has moved. The absolute part determines the starting point of the movement.

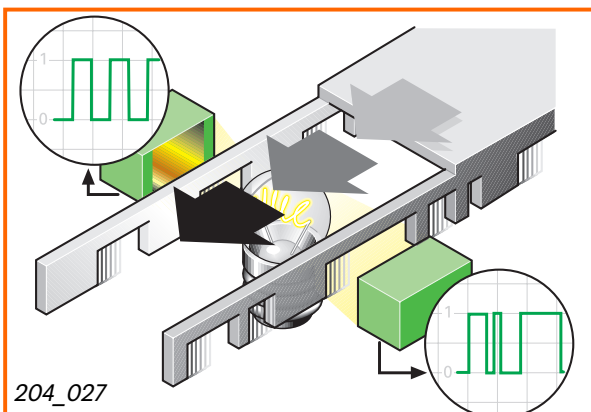

Designed for only one turning motion, the steering angle sender uses the same principle.



Design and function of ESP

Lateral acceleration sender G200

For physical reasons, this sensor should be located as closely as possible to the vehicle's centre of gravity. This is why it is installed in the footwell below the driver's seat.

Task

G200 determines whether and to what extent lateral forces are causing the vehicle to lose directional stability.

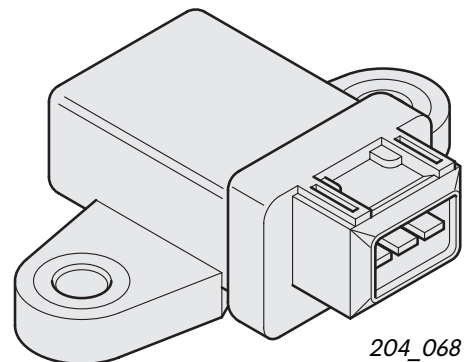

Effects of failure

Without the lateral acceleration measurement, the actual vehicle operating state cannot be calculated in the control unit. The ESP function fails.

Self-diagnosis

The diagnosis establishes whether an open circuit has occurred, or a short circuit to positive or GND exists.

The system is also able to determine whether the sensor is defective or not.

Electric circuit

The lateral acceleration sender is connected to control unit J104 by three wires.

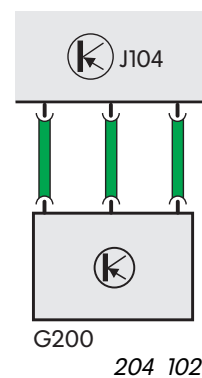

This sensor is highly sensitive to damage.

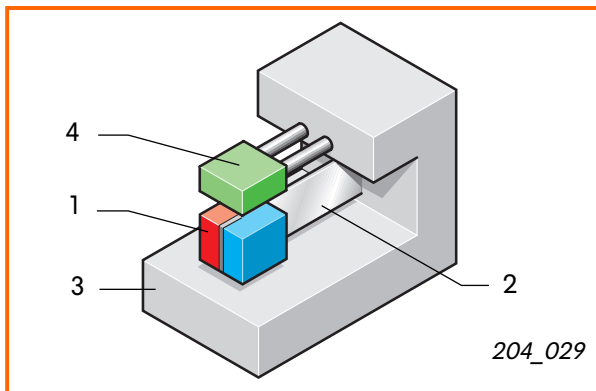

Design

Expressed in simple terms, the lateral acceleration sender comprises a permanent magnet (1), a spring (2), a damper plate (3) and a Hall sensor (4).

The permanent magnet, spring and damper form a magnetic system. The magnet is securely connected to the spring and can oscillate back and forth over the damper plate.

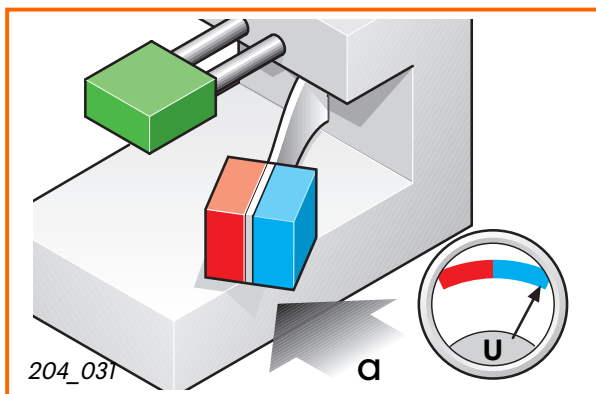

Function

When lateral acceleration (a) acts on the vehicle, the permanent magnet tracks this movement after a time lag caused by its mass moment of inertia. This means that the damper plate, together with the sensor housing and the vehicle as a whole, moves away below the permanent magnet which initially remains at rest.

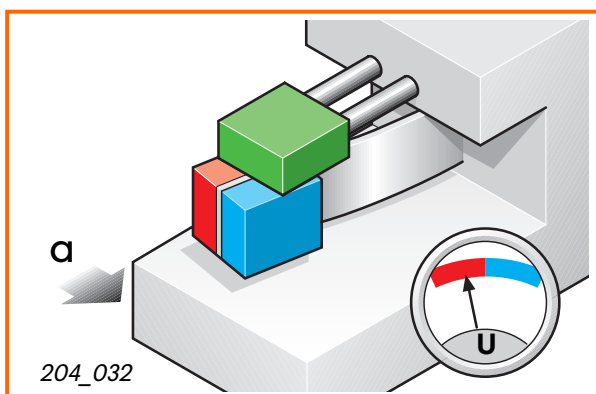

This movement generates electrical eddy currents within the damper plate. These eddy currents in turn build up a field opposing the magnetic field of the permanent magnet.

The strength of the overall magnetic field is reduced in this way. This causes the Hall voltage (V) to change.

The voltage change is directly proportional to lateral acceleration.

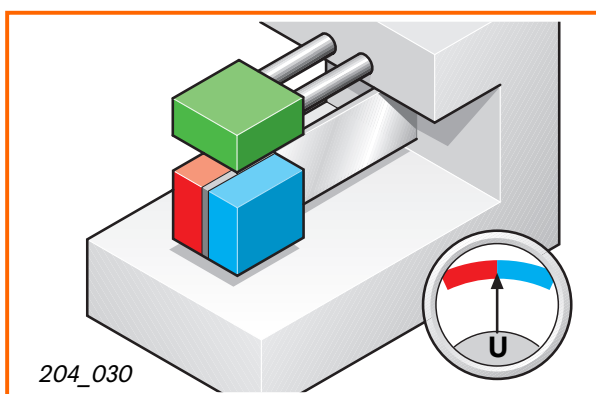

That means that the more movement there is between the damper and magnet, the weaker the magnetic field will become and the more the Hall voltage will change. The Hall voltage remains constant if no lateral acceleration exists.

Design and function of ESP

Yaw rate sender G202

This sensor should also be located as closely as possible to the vehicle's centre of gravity. In the Passat '98, this sensor is housed in the footwell on the front left in front of the central control unit for the convenience system.

Task

The yaw rate sender incorporates space technology. Its task is to determine whether torque is acting on a body. Depending on its installation position, it can detect rotation about one of the axes in space. In the ESP, the sensor must determine whether the vehicle is rotating about its vertical axis.

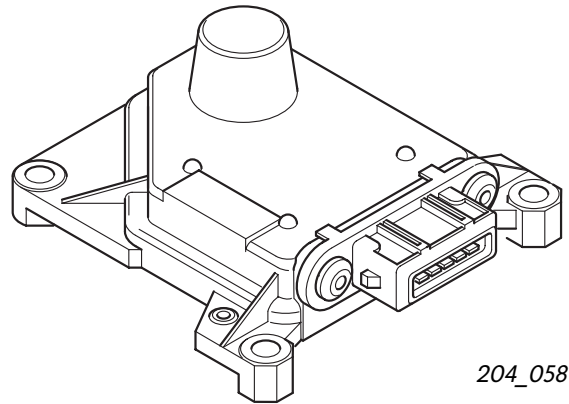

204_058

This process is known as measuring the yaw rate. A sensor which operates according to a gyroscopic principle has been used in the BOSCH system until now. However, this sensor will be superseded by a combined transverse acceleration and steering yaw rate sensor which functions according to a different principle.

Design and function

An integral component is a small, metallic hollow cylinder (1). Eight piezoelectric elements (2) are attached to the hollow cylinder. Four of these elements induce resonance vibration (a) in the hollow cylinder. The other four elements "observe" whether the vibration nodes of the cylinder change. This is precisely what happens when torque acts on the hollow cylinder. The vibration nodes shift (b). This is measured by the piezo elements and is signalled to the control unit which calculates the yaw rate based on this data.

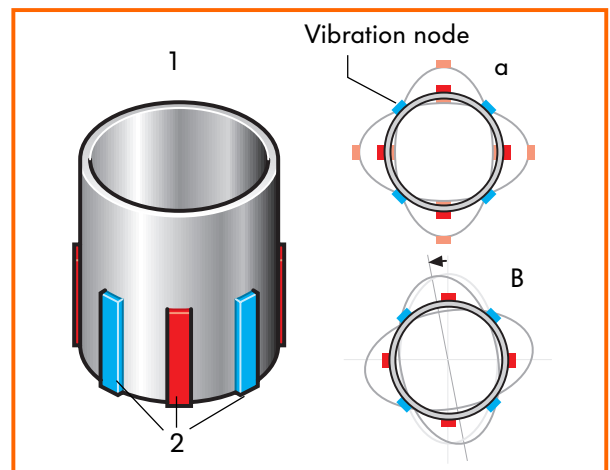

204_047

Combined Sensor

Lateral acceleration sender G200

Yaw rate sender G202

In future, both senders will be combined in a housing.

The advantages of this are:

- smaller fitting dimensions,
- exact alignment of both sensors face to face
 - this alignment cannot be changed - and
- stronger design

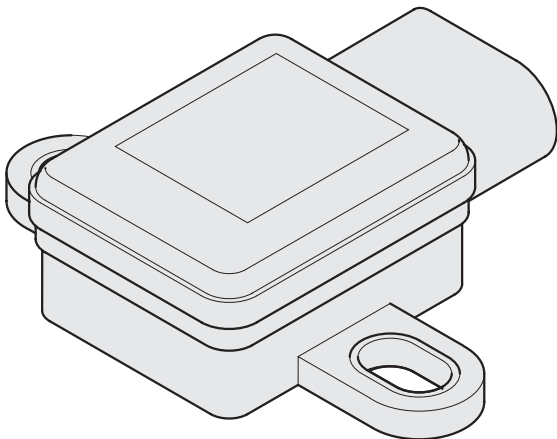

204_075

The components are mounted on a printed circuit board and operate according to micromechanical principles.

The sensor is connected by a six-pin connector. Lateral acceleration is measured according to a capacitive principle.

The yaw rate is determined by measuring the Coriolis acceleration which occurs.

Here is an example:

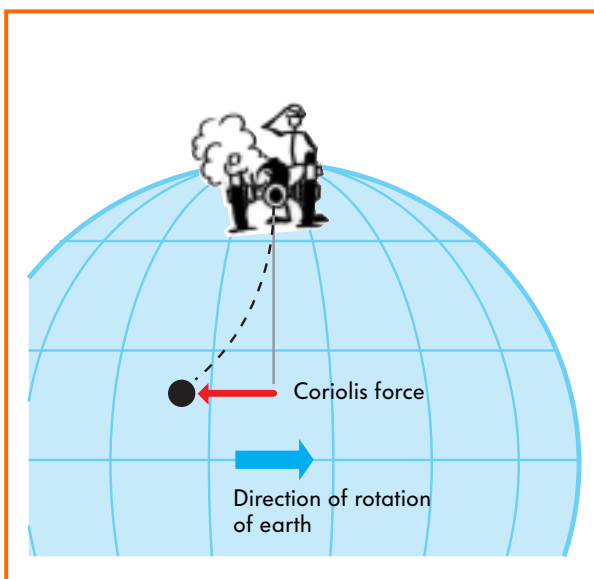

204_126

If you fire a canon ball horizontally in the northern hemisphere, for example, it will no longer appear to travel in a straight line to an observer rotating with the earth. This is caused by a force which accelerates the ball against the direction of rotation of the earth and causes it to deviate from its straight path –or what is known as the Coriolis force.



Design and function of ESP

Design of lateral acceleration sender

The sender is a tiny component on the printed circuit board of the combined sensor.

Expressed in simple terms, the lateral acceleration sender is a capacitor plate with a moving mass which is suspended so that it can move back and forth. Two additional, permanently mounted capacitor plates enclose the movable plate in such a way as to form two series-connected capacitors (K1 and K2). The quantity of electricity which the two capacitors can absorb can now be measured by means of electrodes. This quantity of electricity is known as capacitance C.

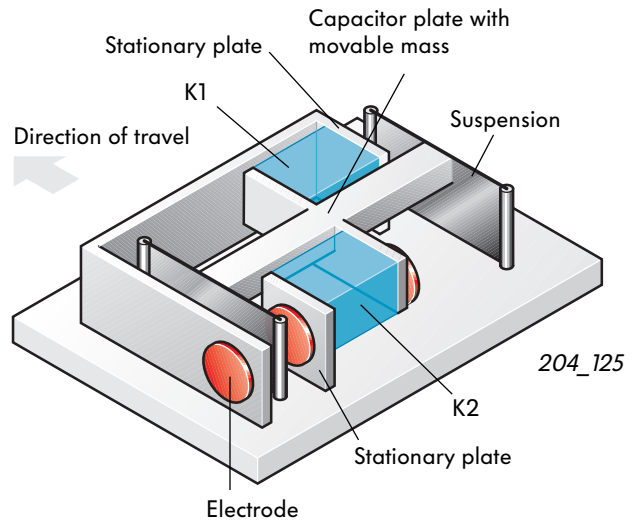

Function

As long as no acceleration acts on this system, the measured quantities of electricity (C1 and C2) of the two capacitors are of equal magnitude.

If lateral acceleration acts on the system, the inertia of the movable mass at the centre plate causes this part opposite the fixed plate to move against the direction of acceleration. This causes the spacing between the plates to change and this also changes the quantities of electricity of the partial capacitors.

The spacing of the plates at capacitor K1 increases and the associated capacitance C1 decreases.

The spacing of the plates of K2 decreases and capacitance C2 therefore increases.

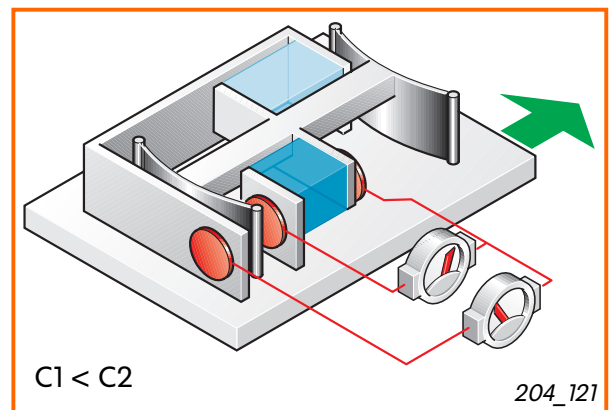
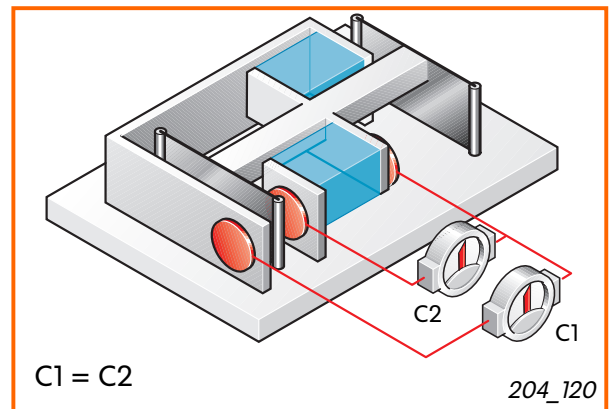

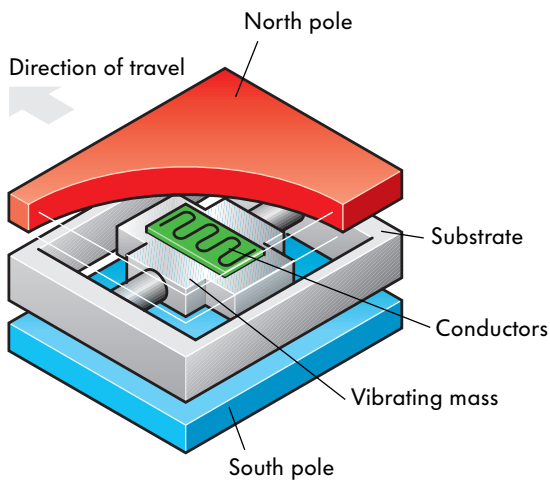

Design of yaw rate sender

The yaw rate sender is mounted on the same board, but is physically separate from the lateral acceleration sensor.

This design can also be explained in simple terms.

Imagine a vibrating mass suspended in a support in a constant magnetic field located between the north pole and south pole. Printed circuits representing the actual sensor are attached to this vibrating mass.

In the actual sender, this configuration exists twice for reasons of reliability.



Function

If you apply an AC voltage ($V\sim$), the part containing the conductors begins to oscillate in the magnetic field.

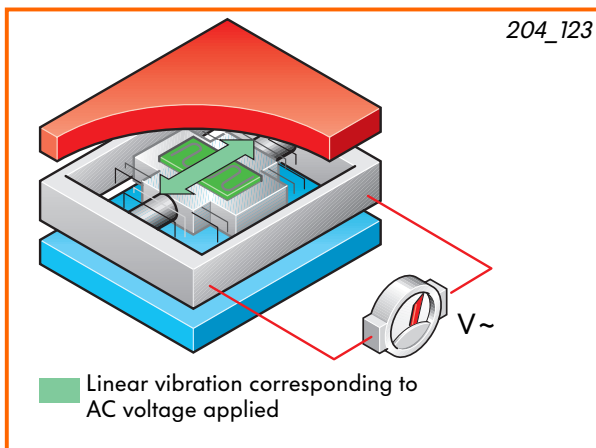

If angular acceleration acts on this structure, the oscillating mass behaves like the canon ball described above due to its inertia. It ceases to oscillate back and forth because a Coriolis acceleration occurs. Since this occurs in a magnetic field, the electrical behaviour of the conductors changes.

When measured, this change therefore shows the magnitude and direction of the Coriolis acceleration. The evaluation electronics calculate the yaw rate from this data.

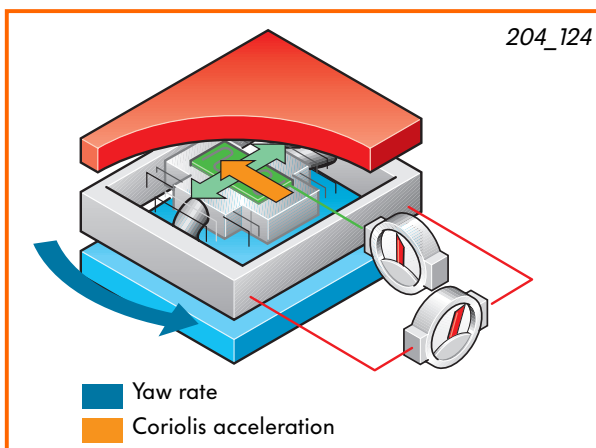

Design and function of ESP

Brake pressure sender G201

is bolted to the hydraulic pump for driving dynamic control.

Task

The brake pressure sender signals the momentary pressure in the brake circuit to the control unit.

From this, the control unit calculates the wheel braking forces and the longitudinal forces acting on the vehicle. If ESP intervention is necessary, the control unit allows for this value when calculating the lateral forces.

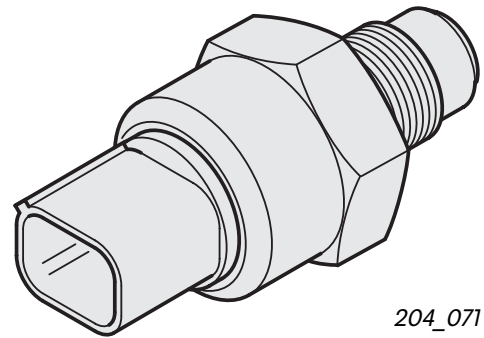

204_071

Electric circuit

The brake pressure sender is connected to the control unit J104 by three wires.

Effects of failure

Without values for current brake pressure, the system is no longer able to calculate the lateral forces correctly. The ESP function fails.

Self-diagnosis

The diagnosis establishes whether an open circuit exists or whether a short circuit to positive or earth has occurred. The system is also able to recognise whether the sensor is defective.

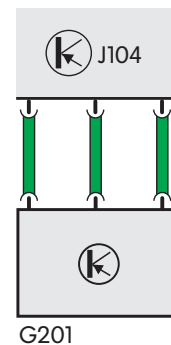

204_105



Do not remove the pressure sensor from the hydraulic pump. It must be replaced together with the pump.

Design

The core of the sensor is a piezoelectric element (a) on which the brake fluid pressure can act plus the sensor electronics (b).

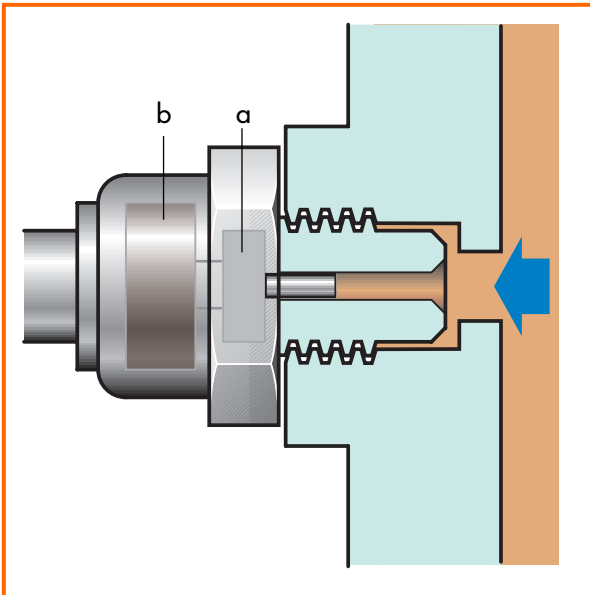

204_033

Function

When the brake fluid applies pressure to the piezoelectric element, the charge distribution in the element changes.

If the piezoelectric element is not subjected to pressure, the electric charges are distributed uniformly (1). If the piezoelectric element is subjected to pressure, the electric charges are shifted in space (2). An electrical voltage is generated.

The higher the pressure, the greater the extent to which the charges are separated. The voltage rises. This voltage is amplified by the built-in electronics and transmitted to the control unit in the form of a signal.

The voltage level is therefore a direct measure of the brake pressure applied.

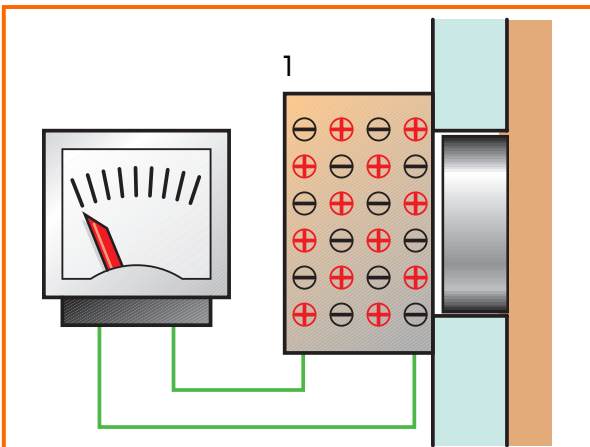

204_034

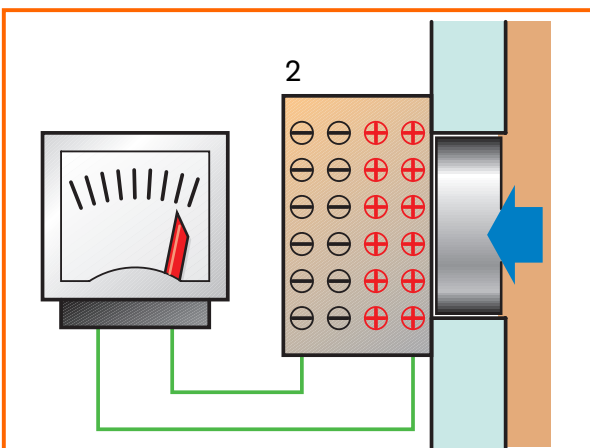

204_035



Design and function of ESP

Button for TCS/ESP E256

This button is located on the dash panel insert, depending on the vehicle type.

It allows the driver to de-activate the ESP function. When the driver depresses the brake pedal or presses the button again, it re-activates the ESP function. If the driver forgets to re-activate ESP, the system re-activates itself when the engine is restarted.

It makes sense to de-activate the ESP function in the following situations:

- when trying to free the vehicle from deep snow or loose surfaces by rocking the car back and forth,
- when driving with snow chains fitted, and
- to run the vehicle on a dynamometer.

The system cannot be de-activated while ESP intervention is in progress or above a certain speed.

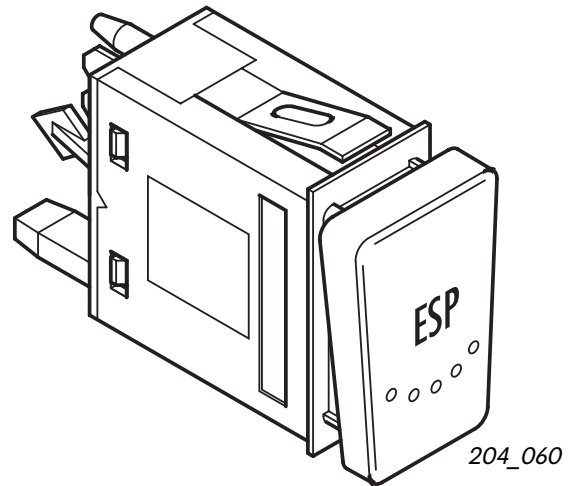

Effects of failure

If the ESP button is defective, the ESP function cannot be de-activated. A malfunction is indicated on the dash panel insert by the TCS/ESP warning lamp.

Self-diagnosis

The self-diagnosis cannot detect a defective button.

Electric circuit

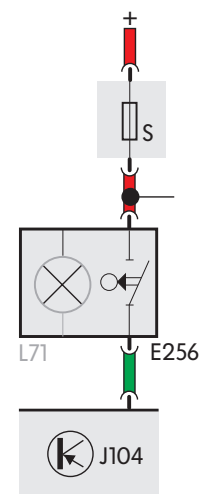

The hydraulic pump for driving dynamic control V156

is mounted below the hydraulic unit in the engine compartment on a common support.

Task

In an ABS system, a small quantity of brake fluid must be pumped through the brake pedal against a high pressure. This task is performed by the return flow pump. However, the return flow pump cannot provide a large quantity of brake fluid at low or zero pedal pressure because the brake fluid has a viscosity that is too high at low temperature.

The ESP system therefore requires an additional hydraulic pump in order to build up the necessary pre-pressure on the suction side of the return flow pump.

The pressure for pre-charging is limited by a nozzle in the master cylinder.

The hydraulic pump for driving dynamic control itself is not regulated.

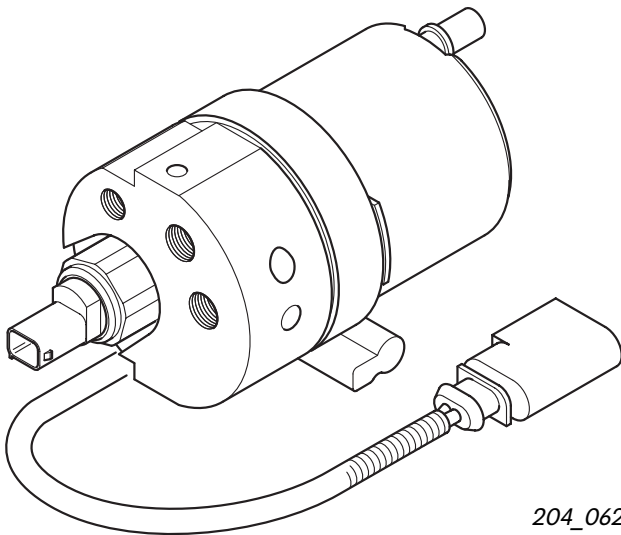

204_062

Electric circuit

Both lines of the hydraulic pump are connected to control unit J104.

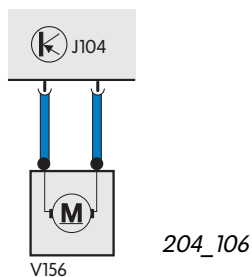

204_106

Effects of failure

The ESP function can no longer be executed. ABS, EDL and TCS are not impaired.

Self-diagnosis

The self-diagnosis indicates open circuit as well as short circuit to positive and GND.



Do not repair the hydraulic pump. It must be replaced as a whole. As a replacement part, the pump is already filled with brake fluid. Do not remove the plug prematurely. Do not use an empty hydraulic pump.

Design and function of ESP

The hydraulic unit

It is mounted on a support in the engine compartment. The exact fitting location may vary depending on vehicle type. In the Passat 97, for example, it is located on the driver's side on the suspension strut tower.

Task

The hydraulic unit has two diagonally split brake circuits.

Compared with older ABS units, the hydraulic unit has been extended by the addition of a changeover valve and an intake valve per brake circuit. The return flow pump is now self-priming.

The changeover valves are as follows:
Driving dynamic control valve -1- N225 and
Driving dynamic control valve -2- N226.

The intake valves are as follows:
Driving dynamic control high-pressure valve -1- N227, and
Driving dynamic control high-pressure valve -2- N228.

The individual wheel brake cylinders are activated by the valves in the hydraulic unit. Three states are possible by activating the intake and exhaust valves of a wheel brake cylinder in the hydraulic unit:

- Raise pressure
- Hold pressure
- Reduce pressure

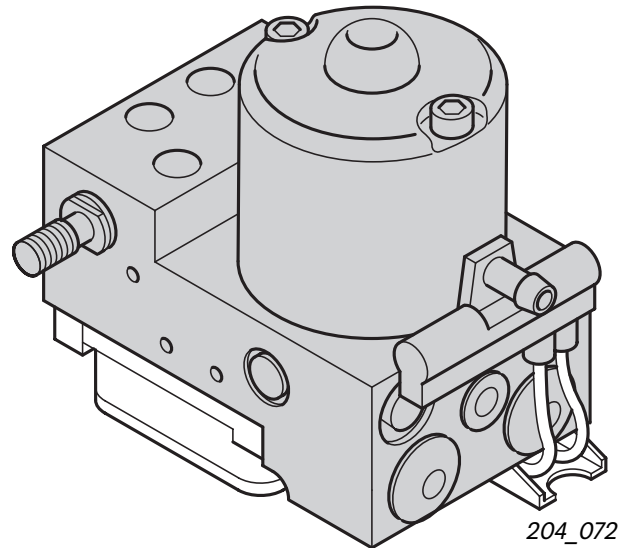

Electric circuit

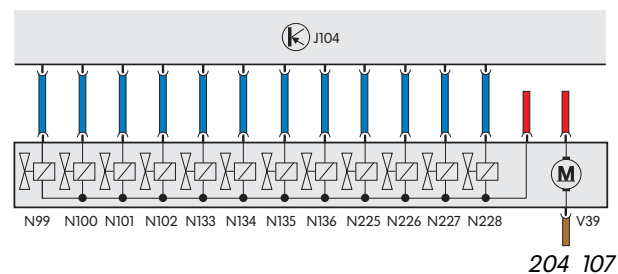

Effects of failure

If proper functioning of the valves cannot be assured, the complete system is de-activated.

Self-diagnosis

Control valves N225 and N226 as well as the high-pressure control valves N227 and N228 are checked for open circuit and short circuit to positive/GND.

Functional diagram

Let us now examine a single brake circuit and one particular wheel in the combination. The partial brake circuit comprises:

- Control valve N225 (a),
- High-pressure valve N227(b),
- Intake valve (c),
- Exhaust valve (d),
- Wheel brake cylinder (e),
- Return flow pump (f),
- Hydraulic pump for driving dynamic control (g) and brake servo (h).

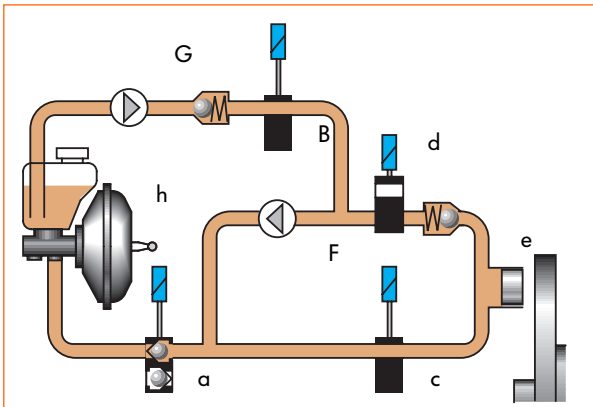

204_036

Raise pressure

When the ESP performs corrective intervention, the hydraulic pump for driving dynamic control begins to convey brake fluid from the reservoir to the brake circuit. As a result, brake pressure is quickly available at the wheel brake cylinders and return flow pump. The return flow pump begins to convey brake fluid in order to continue raising the brake pressure.

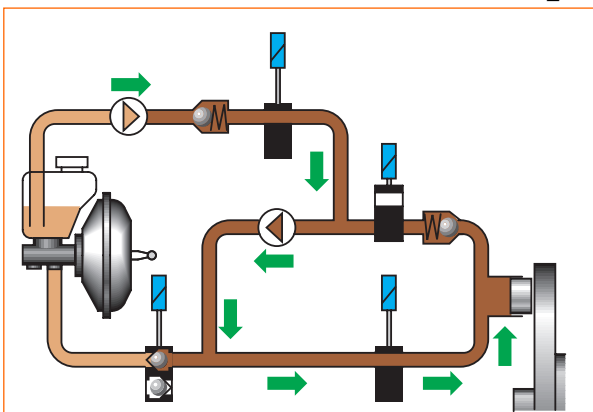

204_037

Hold pressure

The intake valve closes. The exhaust valve remains closed. The pressure cannot escape from the wheel brake cylinders. The return flow pump stops and N227 closes.

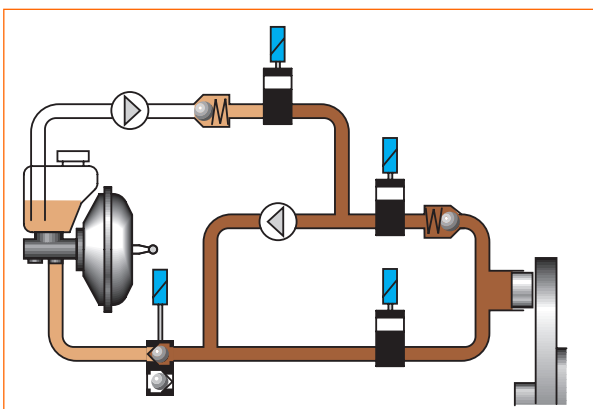

204_038

Reduce pressure

N225 switches to the opposite direction. The intake valve remains closed while the exhaust valve opens. The brake fluid can flow back through the tandem master cylinders into the reservoir.

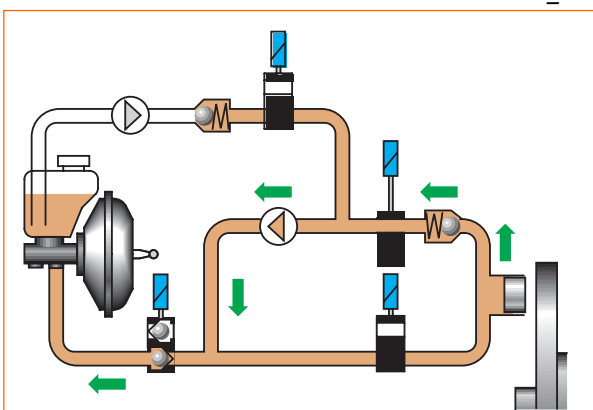

204_039

Functional diagram

BOSCH

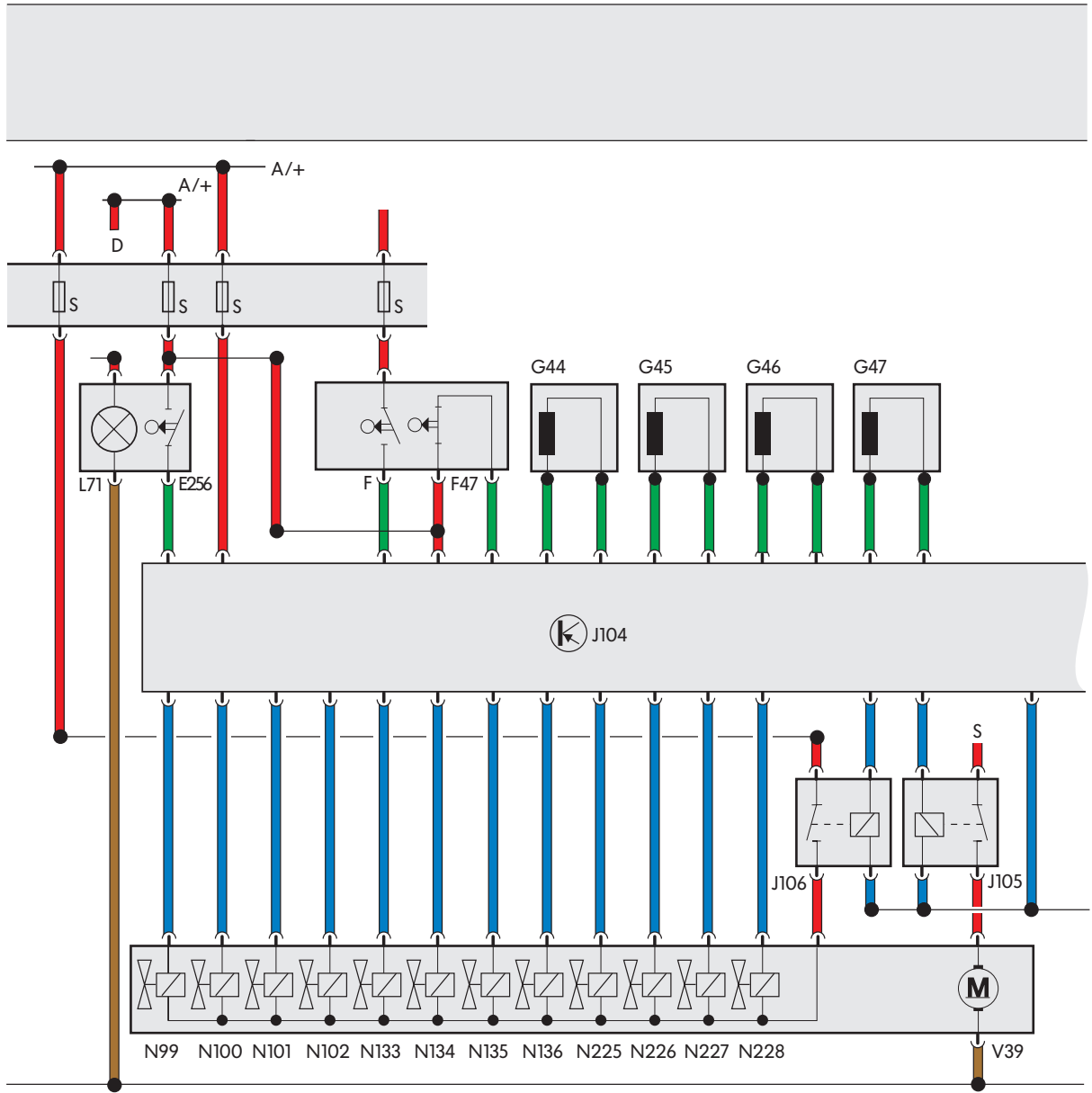

204_092

Components

A/+ Positive connection
D Ignition switch

E256 Button for TCS/ESP

F Brake light switch
F47 Brake pedal switch

G44 Rear right speed sensor
G45 Front right speed sensor
G46 Rear left speed sensor
G47 Front left speed sensor
G85 Steering angle sender
G200 Lateral acceleration sender
G201 Brake pressure sender

G202 Yaw rate sender, in footwell on front left, in front of central control system for convenience system

J104 ABS control unit with EDL/TCS/ESP, in footwell on front right, at engine bulkhead

J105 Relay for return flow pump - ABS, in protective housing for control units, in engine compartment on front left

J106 Relay for solenoid valves - ABS, in protective housing for control units, in engine compartment on front left

J285 Control unit for display unit in dash panel insert

K47 ABS warning lamp

K118 Warning lamp for brake system

K155 TCS/ESP warning lamp

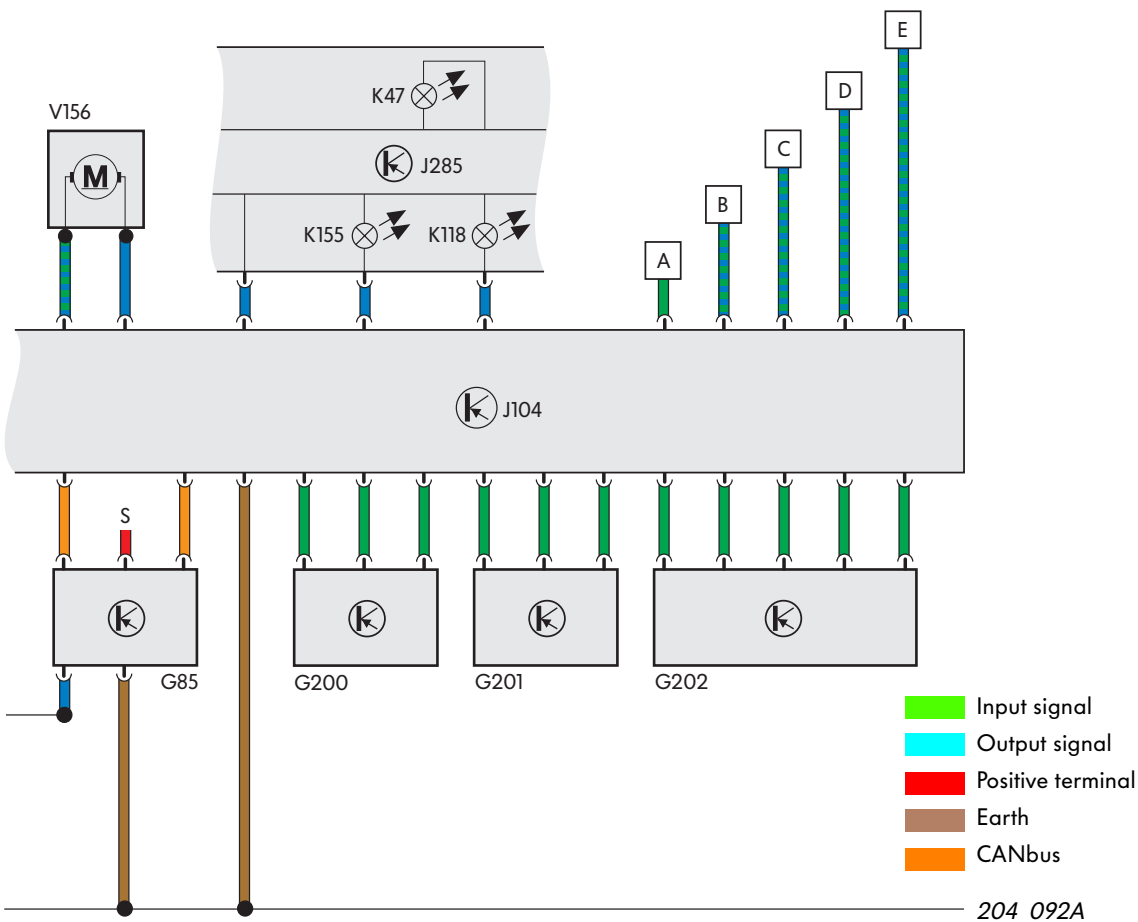

- N99 ABS intake valve, front right
- N100 ABS exhaust valve, front right
- N101 ABS intake valve, front left
- N102 ABS exhaust valve, front left
- N133 ABS intake valve, rear right
- N134 ABS intake valve, rear left
- N135 ABS exhaust valve, rear right
- N136 ABS exhaust valve, rear left
- N225 Driving dynamic control valve -1-
- N226 Driving dynamic control valve -2-
- N227 Driving dynamic control high pressure valve -1-
- N228 Driving dynamic control high pressure valve -2-

S Fuse

V39 Return flow pump for ABS
 V156 Hydraulic pump for driving dynamic control

- A Handbrake warning switch connection
- B Navigation system (only on vehicles with navigation system)
- C Engine management system
- D Gearbox management system (only vehicles with automatic gearbox)
- E Diagnosis wire

Self-diagnosis

Self-diagnosis can be performed with fault readers V.A.G 1551 and V.A.G 1552.

The following functions are available:

- 00 - Automatic test procedure,
- 01 - Interrogate control unit version,
- 02 - Interrogate fault memory,
- 04 - Start basic adjustment,
- 05 - Erase fault memory,
- 06 - End of output,
- 08 - Read measured value block and
- 11 - Login procedure.

The interface between the diagnostic unit and ESP system is the diagnosis plug connection. The exact fitting location is dependent on the vehicle type.



Warning lamps and buttons in the diagnosis

If a fault occurs while corrective intervention is in progress, the system tries its best to complete corrective intervention. At the end of the corrective process, the subsystem is de-activated and the warning lamp is activated.

Faults and activation of warning lamps are always saved to the fault memory.

The ESP function can be de-activated by pressing the button for TCS/ESP.

Warning lamps

Warning lamp for brake system K118



ABS warning lamp K47



TCS/ESP warning lamp K155



	K118	K47	K155
Ignition "on"			
System OK			
TCS/ESP intervention			
TCS/ESP button off ABS remains active, ESP is de-activated when coasting and accelerating, but remains active during ABS intervention			
TCS/ESP failure Fault at yaw rate sender, lateral acceleration sender, steering angle sender or brake pressure sender; in event of ABS failure, emergency ESP function remains active. EBD remains active.			
ABS failure All systems switch off			

System overview

ITT Automotive

Button for TCS/ESP **E256**

Brake light switch **F**

ESP brake recognition switch **F83**,
in brake servo

Speed sensor **G44, G45, G46, G47**

Steering angle sender **G85**

Lateral acceleration sender **G200**

Brake pressure sender -1- **G201**
at master brake cylinder

Yaw rate sender **G202**,
in footwell on front left, in front of
central control system for convenience system

Brake pressure sender -2- **G214**,
at master brake cylinder

Longitudinal acceleration sender **G249**,
at right-hand A pillar (only 4-wheel drive vehicles)

Auxiliary signals

Engine management system

Gearbox management system system

Sensors

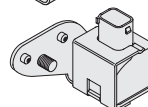
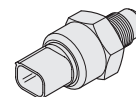
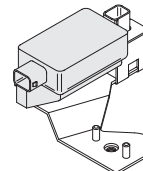
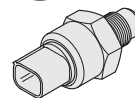
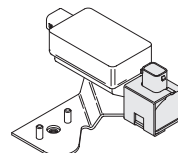
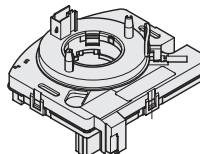
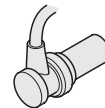
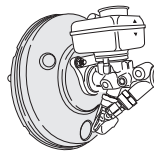
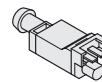
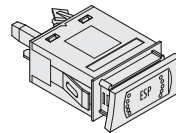

ABS control unit with
EDL/TCS/ESP **J104**,
in engine compartment
on left

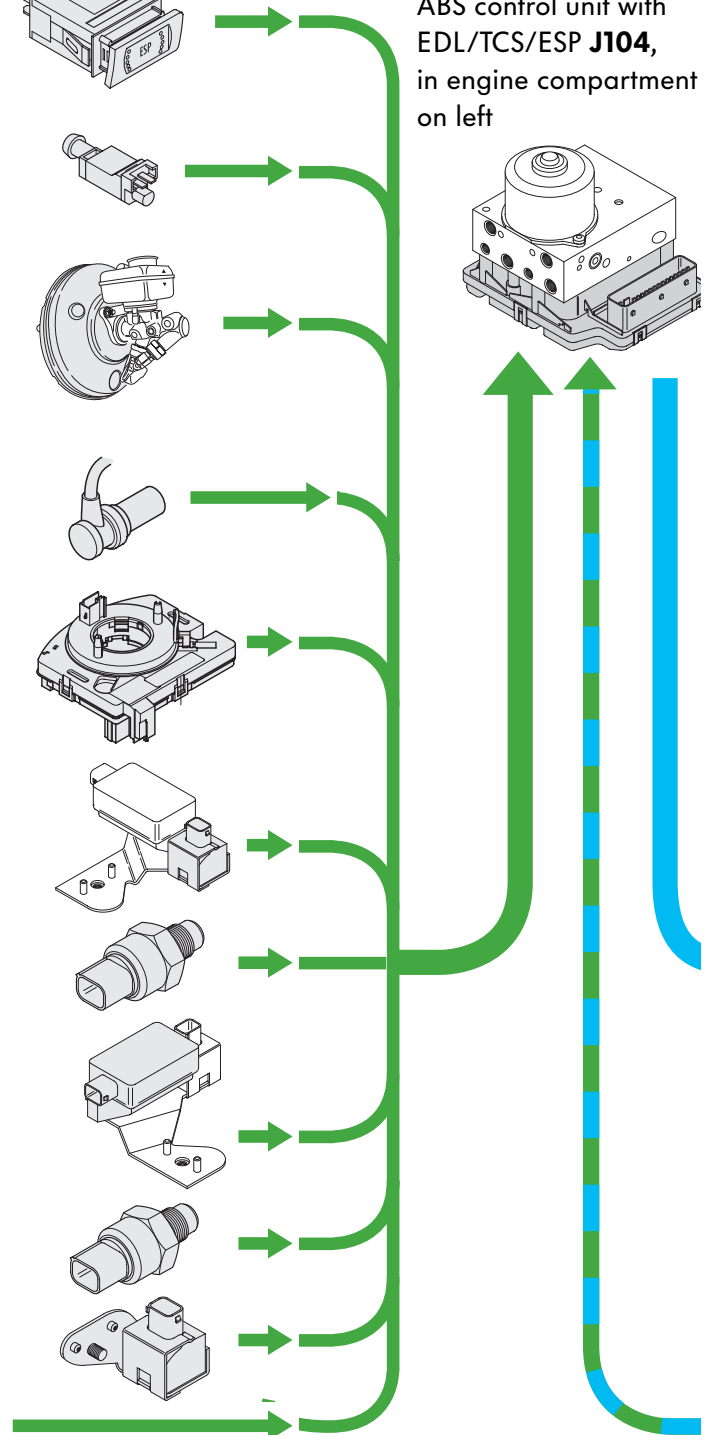
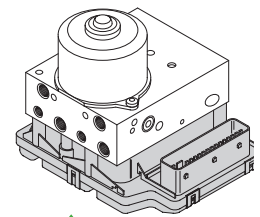

Actuators

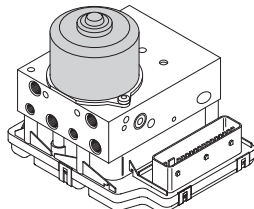

Return flow pump for ABS **V64**

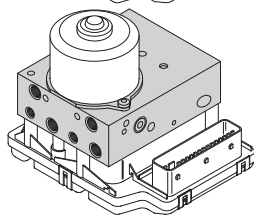

ABS intake valve **N99, N101, N133, N134**

ABS exhaust valve **N100, N102, N135, N136**

Driving dynamic contro valve -1- **N225**

Driving dynamic contro valve -2- **N226**

Driving dynamic control high pressure valve -1- **N227**

Driving dynamic control high pressure valve -2- **N228**

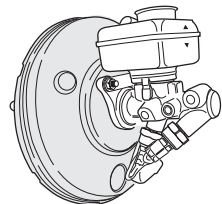

Magnetic coil for brake pressure **N247**,
in brake servo

Relay for brake light suppression **J508**,
on auxiliary relay carrier above relay plate

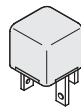

Control unit with display unit in
dash panel insert **J285**

ABS warning lamp **K47**

Warning lamp for brake system **K118**

TCS/ESP warning lamp **K155**

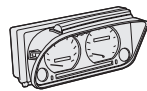

Auxiliary signals

Engine management system

Gearbox management system

Navigation management system

204_093

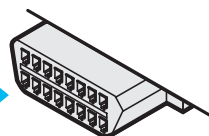

Diagnosis plug connection



Design and function of ESP

Control circuit

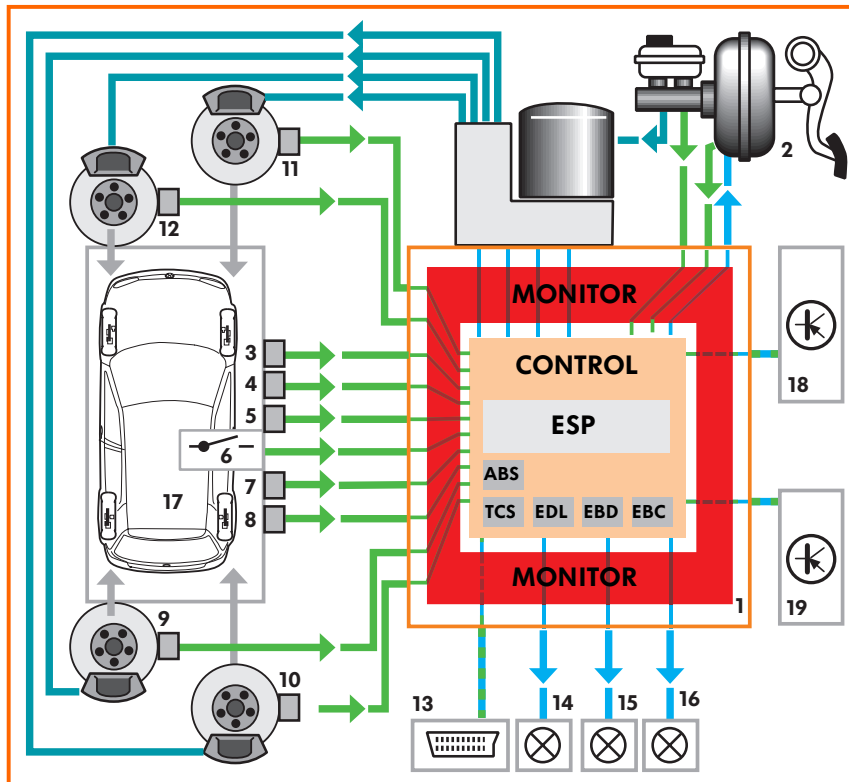

- 1 Hydraulic unit with control unit for ABS with EDL/TCS/ESP
- 2 Active booster with brake pressure sender and release switch
- 3 Longitudinal acceleration sender (quattro/syncro only)
- 4 Lateral acceleration sender
- 5 Yaw rate sender
- 6 Button for TCS/ESP
- 7 Steering angle sender
- 8 Brake light switch
- 9-12 Speed sensor
- 13 Diagnosis wire
- 14 Warning lamp for brake system
- 15 ABS warning lamp
- 16 TCS/ESP warning lamp
- 17 Vehicle and driver behaviour
- 18 Intervention in engine management
- 19 Intervention in gearbox control unit (only vehicles with automatic gearbox)

204_074

The only differences between the control circuits are the way in which the pre-pressure is built up and the inclusion of an additional brake pressure sender on the tandem master cylinder.

On 4-wheel drive vehicles, a longitudinal acceleration sender is also included in the control circuit.

Here, the brake booster assumes the role of the hydraulic pump for driving dynamic control. There is a magnetic coil for brake pressure and a switch for brake recognition in the brake servo.

The control process has been described above. If actual and nominal vehicle handling deviate from one another, the system performs corrective intervention calculations until the information supplied by the sensors indicates that vehicle stability has been restored.



For a more detailed description of the control process, please turn to page 16.

ABS control unit with EDL/TCS/ESP J104

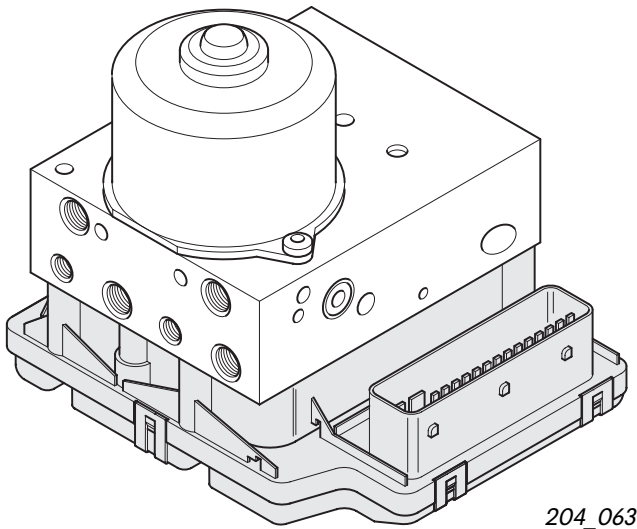

204_063

Effects of failure

In the unlikely event of the control unit failing completely, the driver only has use of the standard brake system without ABS, EDL, EBD, EBC, TCS and ESP.

is combined with the hydraulic unit to form of an assembly; its electronic design is similar to that of the Bosch control unit.

Function

- Control of ESP, ABS, EDL, TCS, EBD and EBC functions,
- Continuous monitoring of all electrical components, and
- Diagnostic support during servicing work in the workshop

After turning on the ignition, the control units perform a self-test. All electrical connections are continuously monitored and the solenoid valves are periodically tested for proper functioning.

Electric circuit

Control unit J104 obtains its supply via the positive connection in the dash panel wiring loom.



Self-diagnosis

The following faults are detected:
 Control unit defective
 Control unit incorrectly encoded
 Fault in power supply
 Hydraulic pump defective
 Implausible signals for ABS operation
 Drive train databus

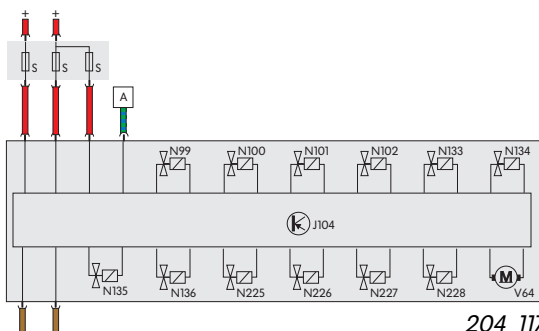

204_117

Design and function of ESP

Steering angle sender G85

is mounted on the steering column between the steering column switch and the steering wheel. The centring ring and coil spring for the airbag are integrated in the steering angle sender and located on its base.

Task

The steering angle sender signals the angle through which the driver turns the steering wheel clockwise or anticlockwise to the ABS control unit with EDL/TCS/ESP.

The steering angle sender can measure an angle of $\pm 720^\circ$, i.e. four full turns of the steering wheel.

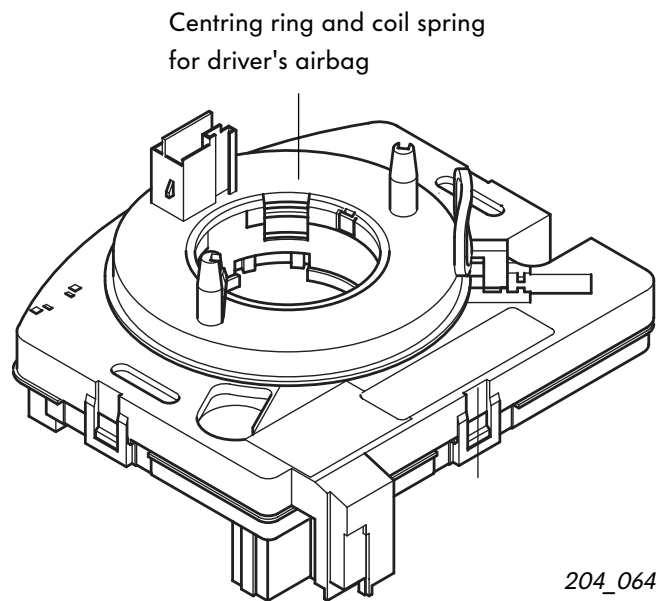

Effects of failure

Without the information supplied by the steering angle sensor, ESP is unable to determine the desired direction of travel. The ESP function fails.

Self-diagnosis

After replacing the control unit or the sensor, the zero position must be re-calibrated.

- Steering angle sender - no communication
- Wrong setting
- Mechanical fault
- Defective
- Implausible signal

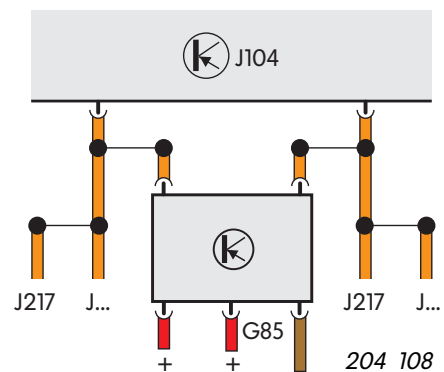

Electric circuit

G85 is the only sensor of the ESP systems which transfers its information directly to the control unit over the CANbus. After turning on the ignition, the sensor is initialised by turning the steering wheel through 4.5° .

This is equivalent to a turning movement of approx. 1.5 cm.



For details of design and function, please turn to page 19.

Lateral acceleration sender G200

For physical reasons, this sensor should be as close to the centre of gravity of the vehicle as possible. Under no circumstances may the fitting location and alignment of the sensor be changed. It is located on the right-hand side next to the steering column and is secured to the yaw rate sender on a bracket.

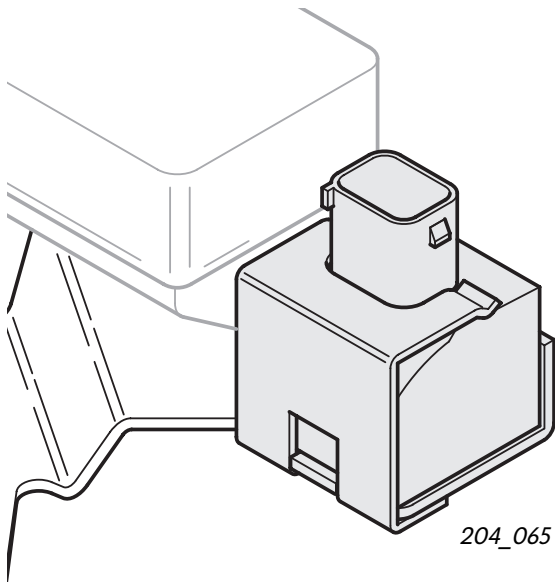

Task

G200 determines what lateral forces can be transferred. G200 therefore provides a sound basis for assessing what vehicle movements are controllable under the prevailing road conditions.

Electric circuit

The lateral acceleration sender is connected to the control unit J104 by three wires.

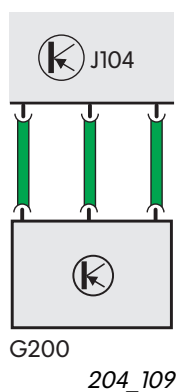

Effects of failure

Without the measurement of lateral acceleration, the actual vehicle operating state cannot be calculated in the control unit. The ESP function fails.



Self-diagnosis

The diagnosis establishes whether an open circuit has occurred or a short circuit to positive or GND exists.

The system recognises whether the sensor signal is plausible.



This sensor is also very sensitive to damage.

Design and function of ESP

Design

The lateral acceleration sender operates according to a capacitive principle. What does this mean?

Imagine that the sensor comprises two capacitors connected in series. The common, central capacitor plate can be moved by applying a force.

Each capacitor has a capacitance, i.e. it can absorb a certain amount of electric charge.

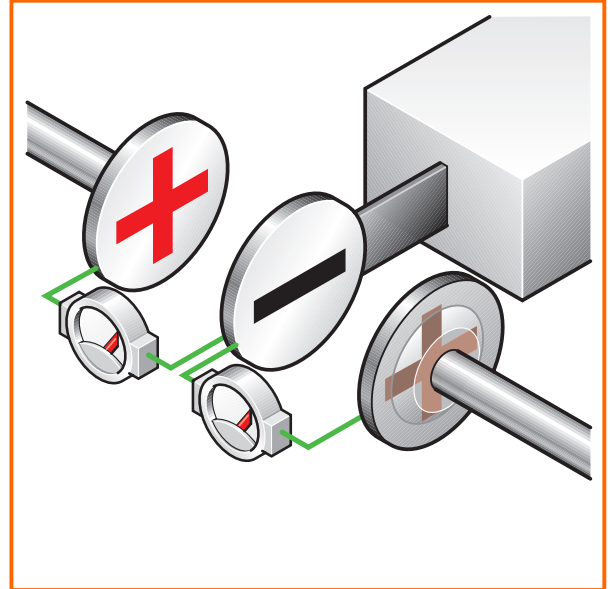

204_040

Function

As long as no lateral acceleration is acting on the central plate, the gap between the central plate and the outer plates remains constant, with the result that the electrical capacitance of the two capacitors is equal.

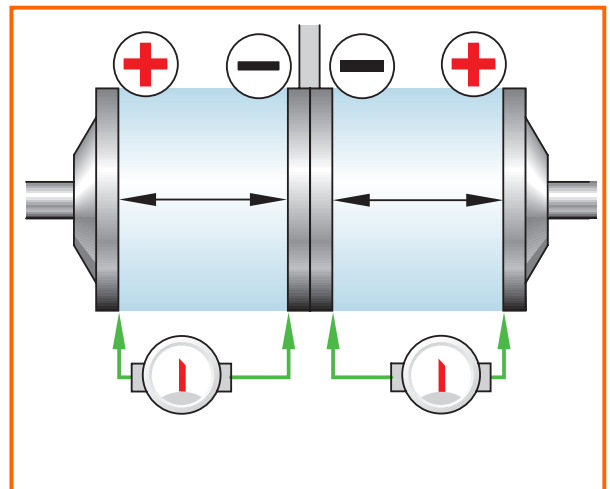

204_041

If lateral acceleration acts on the central plate, the one gap increases and the other decreases. The capacitance of the partial capacitors also changes.

The electronics can determine the direction and quantity of lateral acceleration from a change in capacitance.

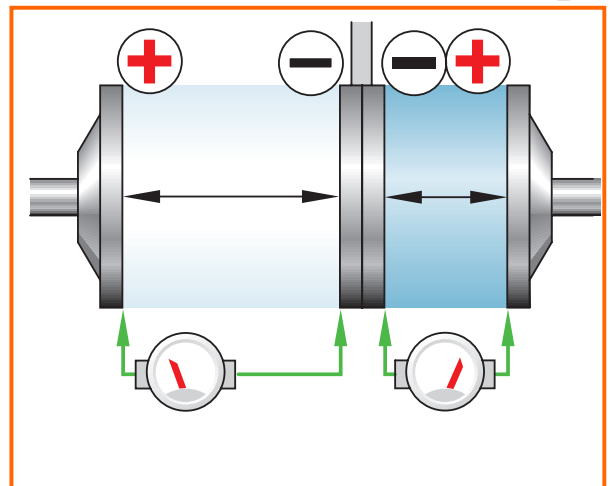

204_042



Yaw rate sender G202

The required installation position close to the vehicle's centre of gravity was made possible by mounting the yaw rate sender, together with the lateral acceleration sender, on a bracket.

Unlike the BOSCH combined sensor system, the ITT uses two separate sensors which can be replaced individually.

Task

G202 ascertains whether torque is acting on a body. Depending on the installation position, it can detect rotation about one of the axes in space. In the ESP, the sensor must determine whether the vehicle has rotated about its vertical axis. This process is known as measuring the yaw rate.

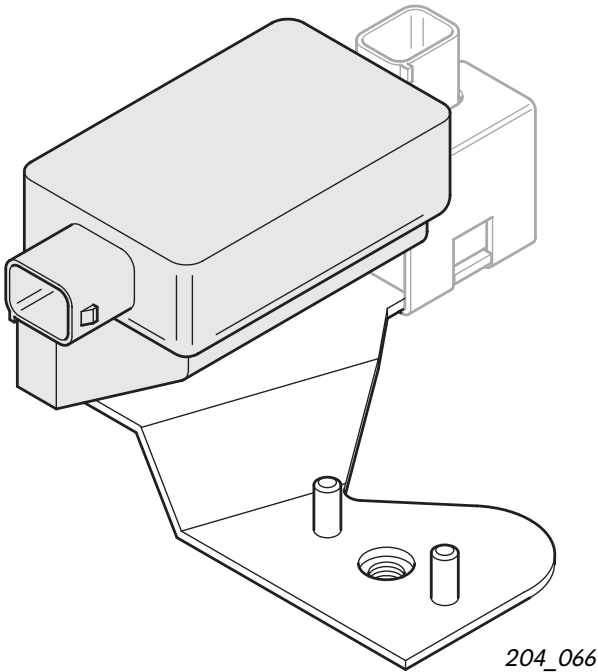

Electric circuit

The yaw rate sender is connected to the control unit J104 by three wires.

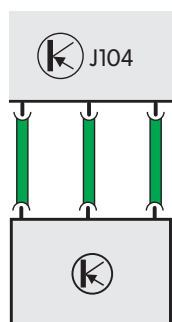

G202
204_110

Effects of failure

Without the measurement of the yaw rate, the control unit is unable to ascertain whether the vehicle has begun to swerve. The ESP function fails.

Self-diagnosis

The diagnosis establishes whether an open circuit has occurred or a short circuit to positive or GND exists. The system also ascertains whether the sensor signal is plausible.



Design and function of ESP

Design

A basic component of ESP is a micromechanical system with a double tuning fork comprising a silicon crystal housed in a small electronic component on the sensor board.

Here is a simplified drawing of the double tuning fork. Its mid-section is connected to the other silicon element which we have omitted here for the sake of clarity.

The double tuning fork comprises an exciter tuning fork and a measuring tuning fork.

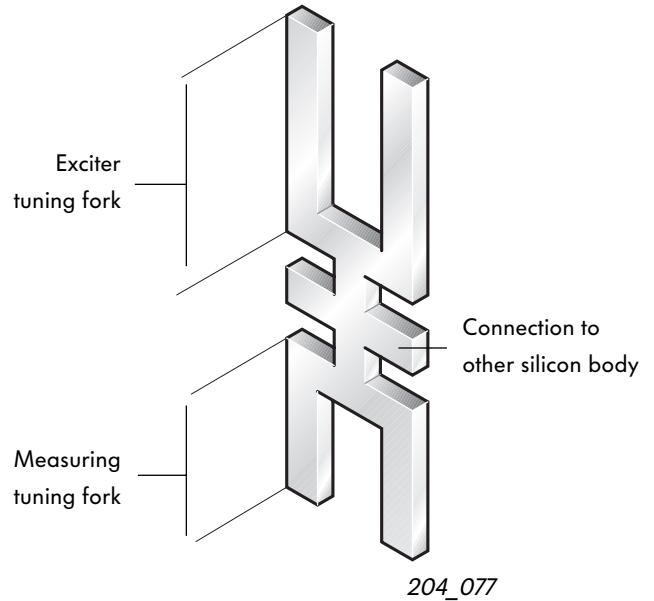

Function

Applying an AC voltage induces a sympathetic voltage in the silicon tuning fork.

The two halves are matched so that the exciter tuning fork has a resonance vibration at exactly 11kHz and the measuring tuning fork at 11.33kHz. Applying an AC voltage at a frequency of exactly 11 kHz to the double tuning fork induces sympathetic vibration in the exciter tuning fork, but not in the measuring tuning fork.

A tuning fork vibrating in resonance reacts more slowly to the application of force than a non-oscillating mass.

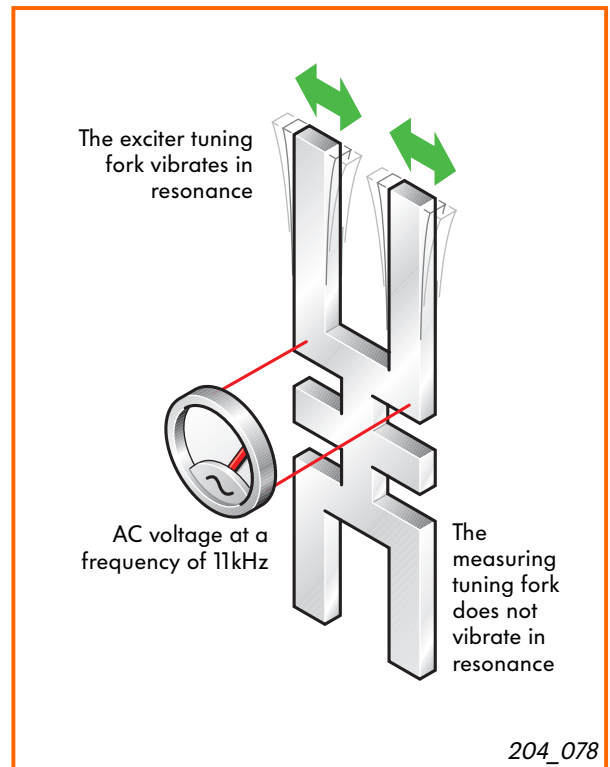

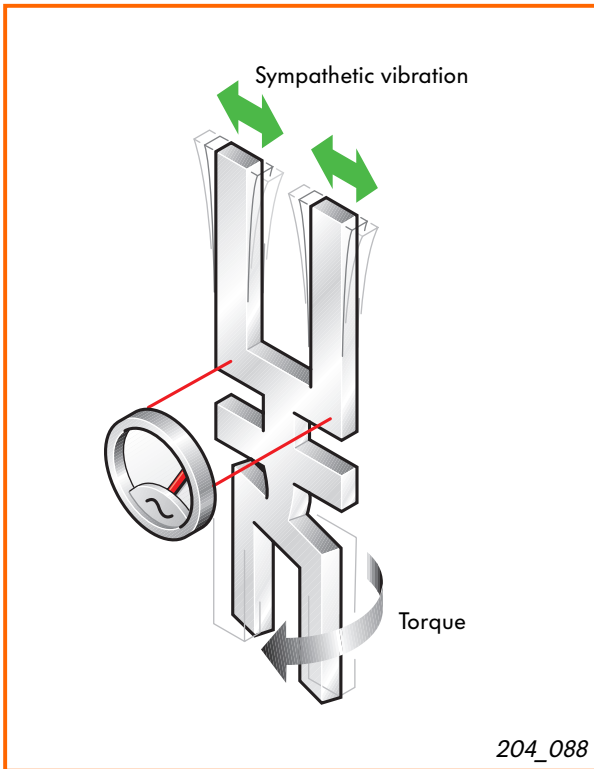

This means that, whereas angular acceleration causes the other half of the double tuning fork and the remainder of the sensor together with the vehicle to move, the oscillating part of the double tuning fork lags behind this movement. As a result, the double tuning fork becomes twisted like a corkscrew.

The twisting effect changes the charge distribution in the tuning fork. This is measured by electrodes, evaluated by the sensor electronics and transmitted to the control unit in the form of a signal.



Design and function of ESP

Longitudinal acceleration sender G249

is located on the A pillar on the right and is only required on 4-wheel drive vehicles.

On vehicles that are driven at one axle only, the system calculates the vehicle's longitudinal acceleration from the data supplied by the sender for brake pressure, the signals supplied by the speed sensors on the wheels and information from the engine management system.

On 4-wheel drive vehicles fitted with Haldex viscous coupling, the front and rear wheels are joined by a rigid coupling. The calculated true vehicle road speed, which is determined from the individual speeds, may be too inaccurate under certain conditions at low coefficients of friction and when the Haldex viscous coupling is closed. The longitudinal acceleration measured is used to verify the calculated vehicle road speed.

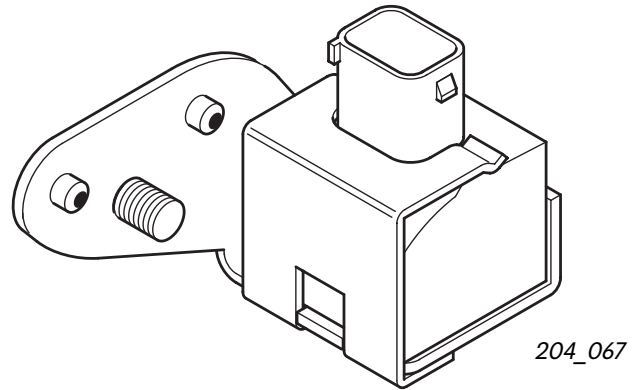

Effects of failure

Without the additional measurement of longitudinal acceleration on 4-wheel drive vehicles, it may be impossible under unfavourable conditions to determine the vehicle's road speed accurately. The ESP and TCS functions fail. The EBD function remains active.

Self-diagnosis

The diagnosis establishes whether an open circuit has occurred or a short circuit to positive or GND exists. The system also recognises whether the sensor signal is plausible or not.



For further details of design and function, please turn to page 42.

This sender is installed rotated through 90° in relation to the lateral acceleration sender.

Electric circuit

The longitudinal acceleration sender is connected to control unit J104 by three wires.

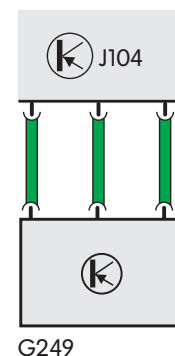

Button for TCS/ESP E256

This button is located on the dash panel insert, depending on vehicle type.

It enables the driver to de-activate the ESP/TCS function. This is indicated by the TCS/ESP warning lamp.

Pressing this button again re-activates the TCS/ESP function.

If the driver forgets to re-activate the TCS/ESP function, the system re-activates itself when the engine is restarted.

It makes sense to de-activate the ESP function in the following situations:

- when trying to free the vehicle from deep snow or loose surfaces by rocking the car back and forth,
- when driving with snow chains fitted and
- for running the vehicle on a dynamometer.

The system cannot be de-activated while ESP intervention is in progress.

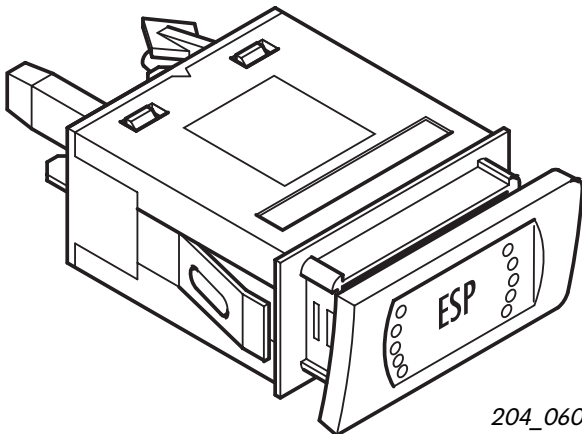

204_060

Electric circuit

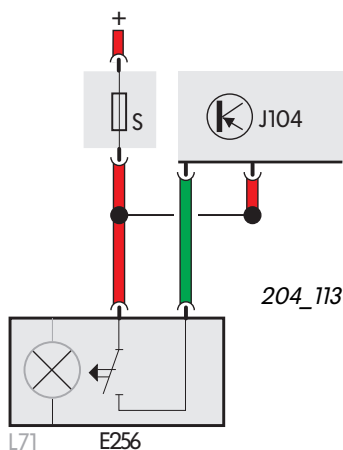

204_113

Effects of failure

If the ESP button is defective, the ESP function cannot be de-activated.

Self-diagnosis

The self-diagnosis does not detect a defective button.



Design and function of ESP

Brake pressure sender - 1 - G201 Brake pressure sender - 2 - G214

Both senders are bolted to the tandem master cylinder.

Task

To ensure maximum safety, there are two brake pressure senders. In this case, too, the system has a redundant design.

As with the BOSCH ESP system, the task of this system is to supply measured values for calculating the braking force and for controlling the pre-charging function.

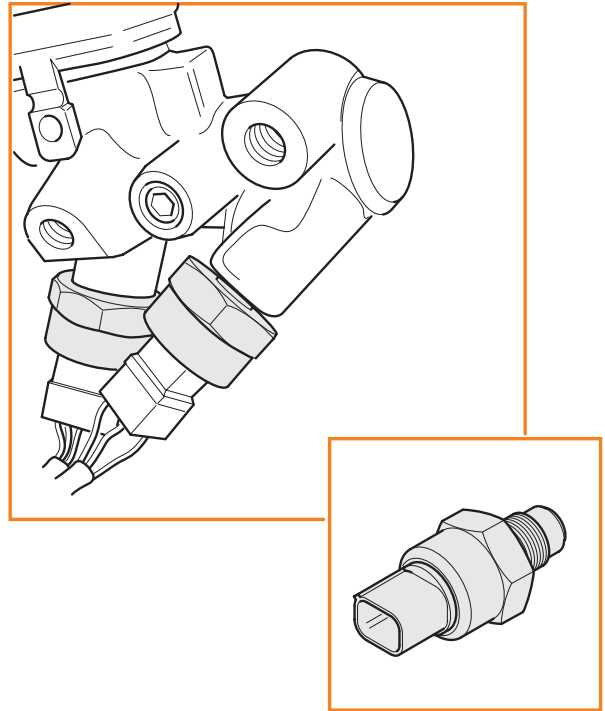

204_070

Effects of failure

It is practically impossible for both sensors to fail simultaneously. If the control unit does not receive a signal from one of the two senders, the ESP function is disabled.

Self-diagnosis

The diagnosis establishes whether an open circuit has occurred or a short circuit to positive or GND exists.

The system also checks whether the signals of the two sensors are plausible or not.

Electric circuit

Each of the brake pressure senders is connected to control unit J104 by three wires.

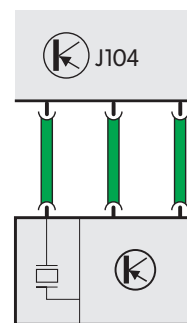

G201

204_114

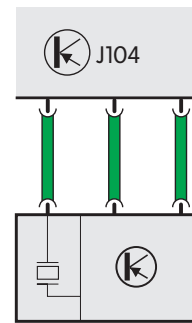

G214

204_115

Design

Both sensors are capacitive-type sensors.

For the sake of clarity, we are using here a simplified diagram of the plate capacitor in the interior of the sensor (a) on which brake fluid pressure can act.

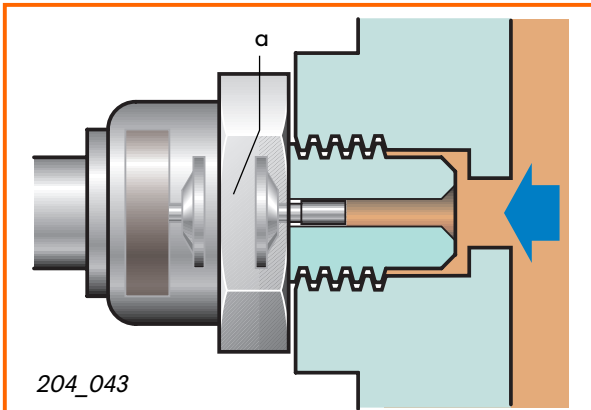

Function

Due to the gap (s) between the two plates, the capacitor has a defined capacitance C . This means that it can absorb a certain amount of electric charge.

Capacitance is measured in Farady.

One plate is fixed, the other can be moved by brake fluid pressure.

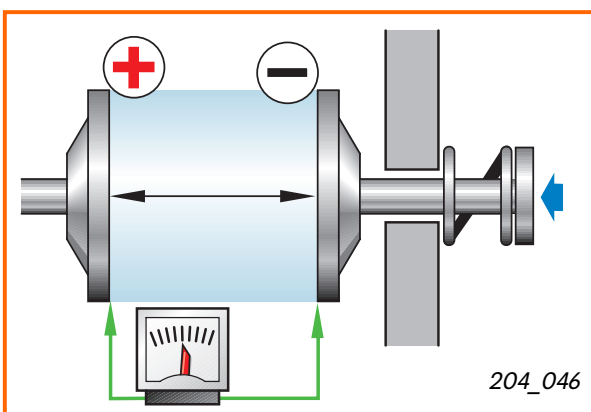
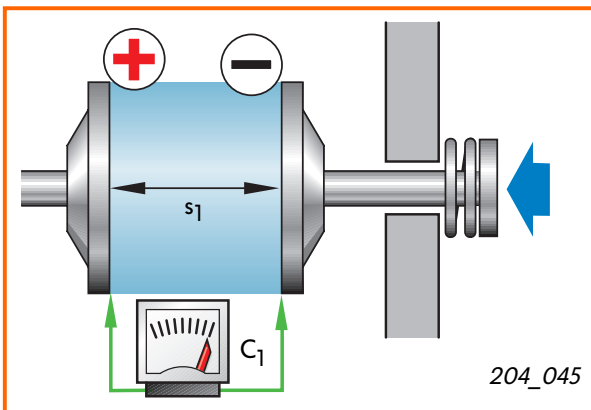
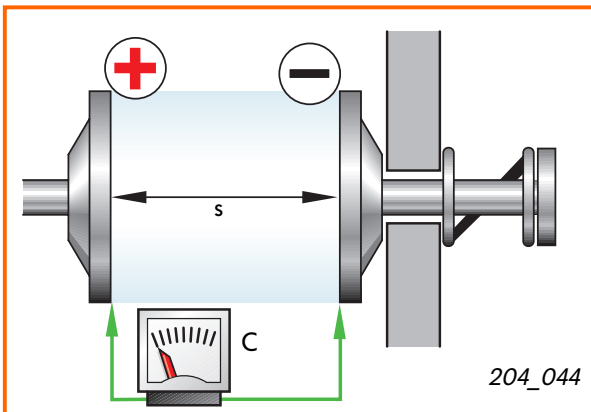

When pressure acts on the movable plate, the gap (s_1) between the two plates becomes smaller and the capacitance C_1 increases.

If the pressure drops again, and the plate moves back.

The capacitance is again low.

A change in capacitance is therefore a direct measure of pressure change.



Design and function of ESP

Active brake servo with tandem master cylinder

The active brake servo or booster differs fundamentally from the previous model. Over and above the usual function, i.e. increasing the foot pressure on the brake pedal by means of a partial vacuum which is generated by the intake manifold or from a vacuum pump, the active brake servo assumes the task of building up the pre-pressure for ESP intervention. This is necessary since the intake capacity of the return flow pump is not always sufficient to generate the required pressure. The reason for this is the high viscosity of the brake fluid at low temperatures.

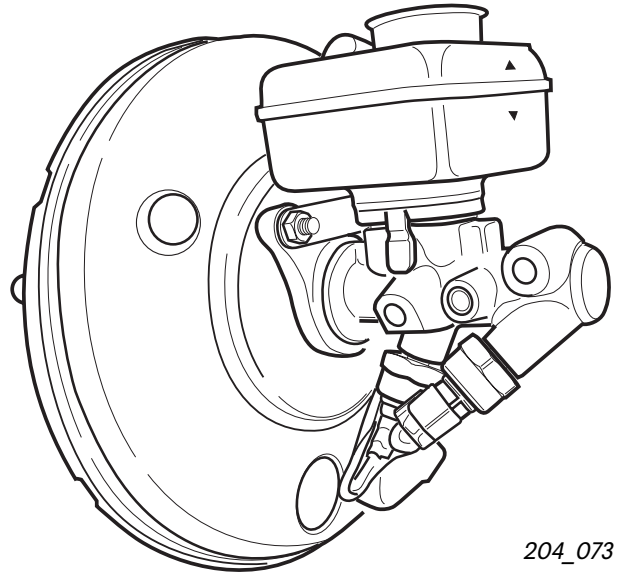

204_073

Advantage of the active brake servo:

- No additional installation work is necessary

Effects of failure

If the magnetic coil or switch F83 fails, the ESP function will no longer be available.

Self-diagnosis

The following faults are detected:
open circuit,
short circuit to positive or GND and
defective component.

Electric circuit

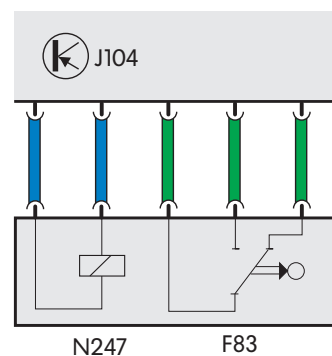

204_116

Design

First of all, let us observe an overview of the design.

The booster comprises a modified tandem master cylinder (a) and the brake servo (b). The brake servo is subdivided into a vacuum part (c) and a pressure part (d) which are separated by a diaphragm. It also has a valve piston and magnet unit (e).

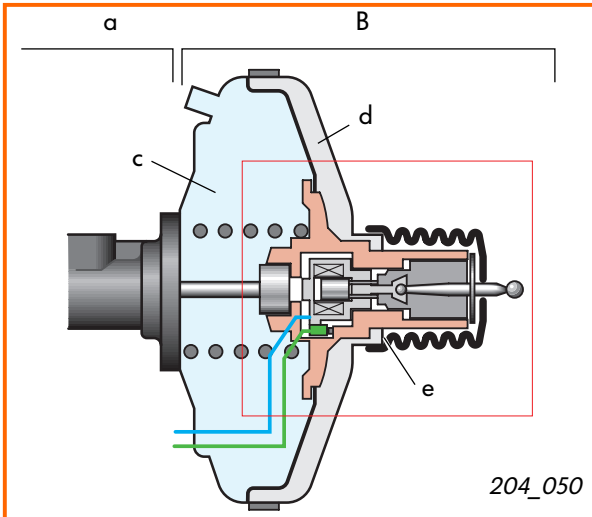

The valve piston and magnet unit is electrically connected to the ESP system.

It comprises:

- ESP brake recognition switch F83,
- magnetic coil for brake pressure N247,
- various air ducting valves which we shall not explain here in greater detail.

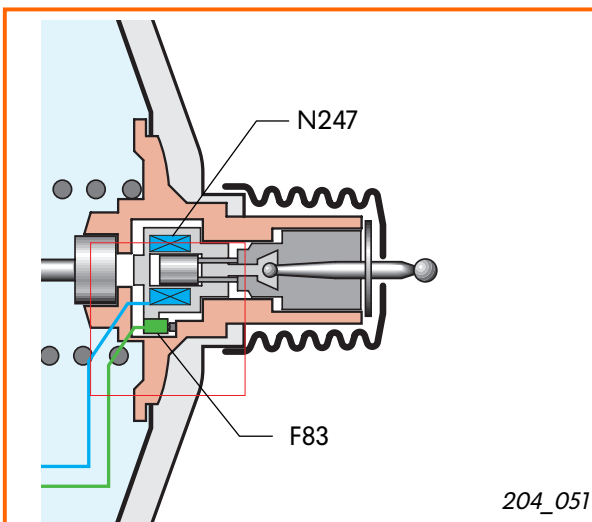

The ESP brake recognition switch is also known as the “release switch”.

It is a two-way switch.

If the brake pedal is not activated, the mid-position contact is connected to signal contact 1. If the pedal is activated, signal contact 2 closes. Since only one contact is always closed, the signal which the switch generates is always clearly defined.

The release switch therefore offers a high level of intrinsic safety.

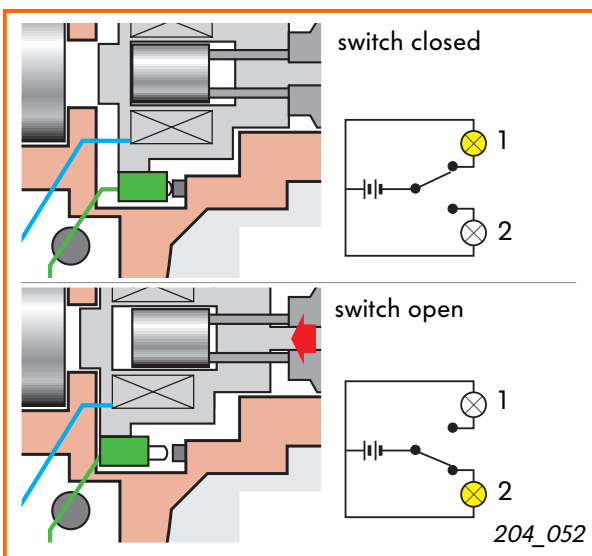

Design and function of ESP

Function of valve piston and magnet unit

The valve piston and magnet unit produce the pre-pressure of 10 bar which is required on the suction side of the return flow pump even if the brake pedal is not operated by the driver.

If the system recognises that ESP intervention is necessary and that the driver has still not activated the brake pedal, the control unit for ABS/EDL/TCS and ESP activates the magnetic coil for brake pressure.

A magnetic field is built up inside the magnetic coil and draws a metal core into the coil. This movement causes the valves within the valve piston and magnet unit to open. A quantity of air sufficient to build up the required pre-pressure of 10 bar then flows into the brake servo.

If the nominal pre-charging pressure is exceeded, the electric current supply to the magnetic coil is reduced. The metal core retracts from the coil and the pre-pressure drops. On completion of the ESP control cycle or when the brake is operated by the driver, the control unit switches the magnetic coil off.

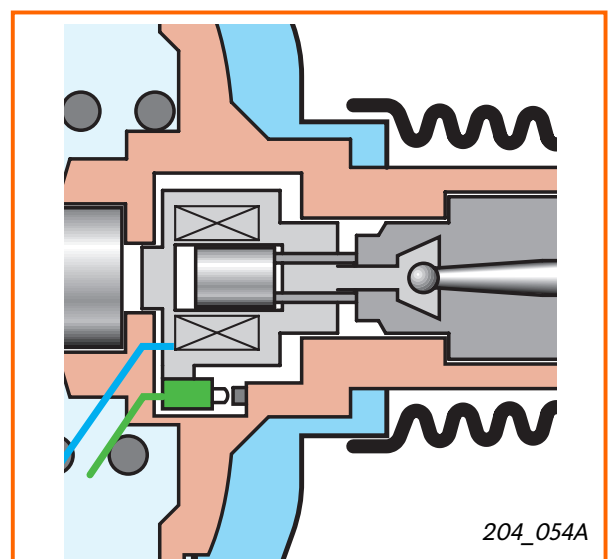
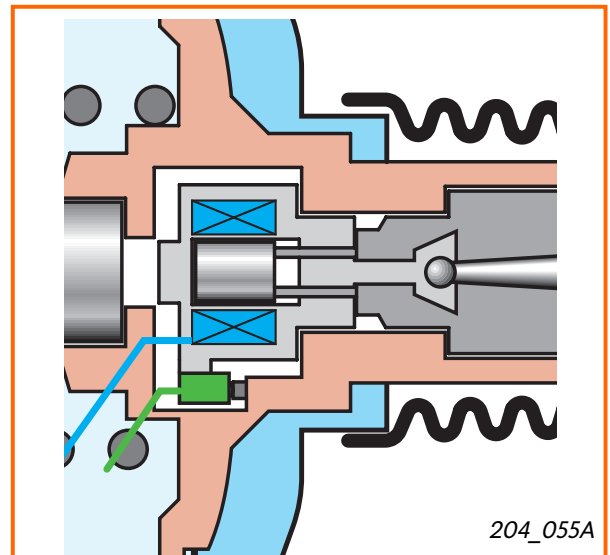
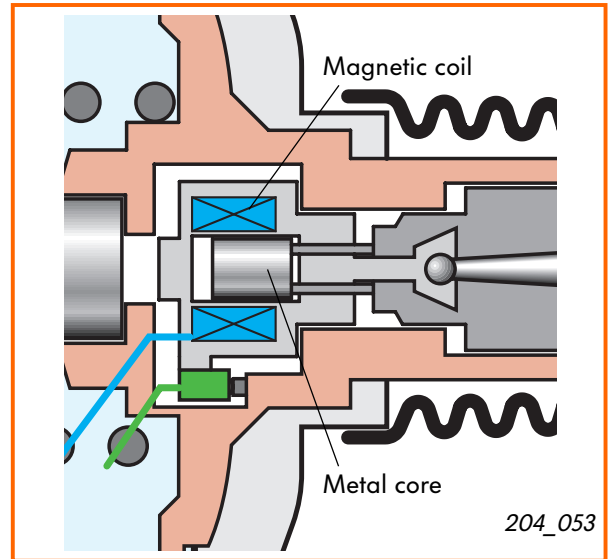

Function of ESP brake recognition switch

The brake recognition switch informs the ESP system when the driver applies the brakes. If the mid-position contact in the switch is closed at signal contact 1, the system assumes that it has to generate the necessary pre-pressure by itself.

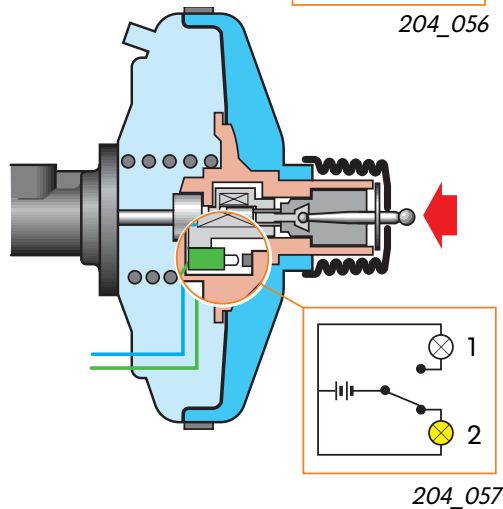
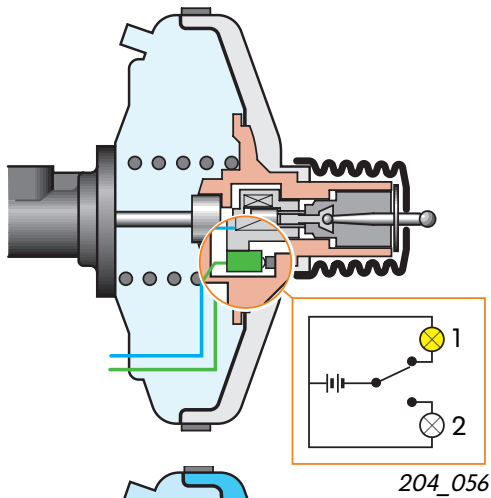

When the driver operates the brake pedal, the magnetic coil is moved in the direction of the master brake cylinder. This causes the mid-position contact in the switch to change over from signal contact 1 to signal contact 2, indicating to the system that the driver has applied the brake. Since the required pre-pressure is now generated by the driver depressing the pedal, the magnetic coil need not be activated.

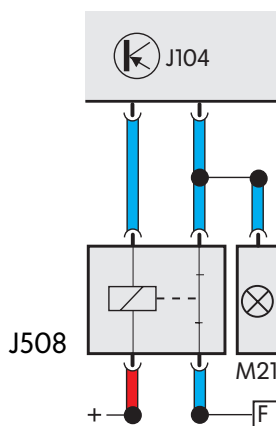

Relay for brake light suppression J508

When the ESP system activates the magnetic coil, the brake pedal may move as a result of tolerances to such an extent that the brake light switch closes the contact to the brake lights.

To ensure that following road users are not irritated by this, relay J508 interrupts the connection to the lights for the duration of magnetic coil activation.



Design and function of ESP

Hydraulic unit

is mounted on a support in the engine compartment. The exact fitting location may vary depending on vehicle type.

Task

The hydraulic unit has two diagonally split brake circuits.

Compared with previous ABS units, the hydraulic unit has been extended to include an extra change-over valve and intake valve per brake circuit. The return flow pump is now self-priming.

The changeover valves are:

- Driving dynamic control valve -1- N225 and
- Driving dynamic control valve- 2- N226.

The intake valves are:

- Driving dynamic control high pressure valve -1- N227 and
- Driving dynamic control high pressure valve -2- N228.

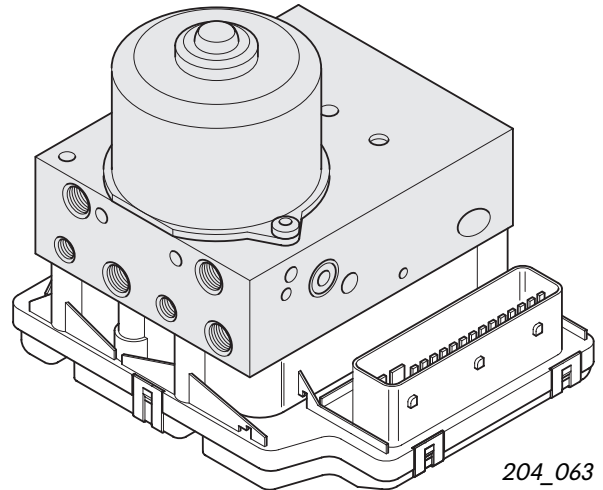

A distinction is made between three system operating states:

- Increase pressure
- Hold pressure and
- Reduce pressure

Effects of failure

If proper functioning of the valves cannot be assured, the complete system is de-activated.

Self-diagnosis

All valves and the pumps are monitored continuously. If electrical faults occur, the control unit must be replaced.



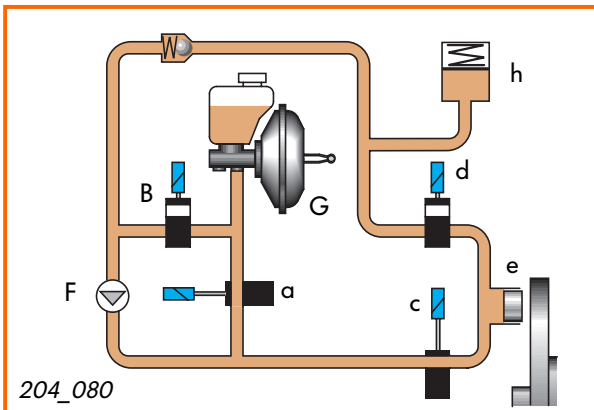

Functional diagram

Here, too, we shall only observe one wheel in a brake circuit. The basic components are:
 Control valve N225 (a),
 Driving dynamic control high pressure valve N227 (b),
 Intake valve (c),
 Exhaust valve (d),
 Wheel brake cylinder (e),
 Return flow pump (f),
 Active brake servo (g) and
 Low-pressure accumulator (h).

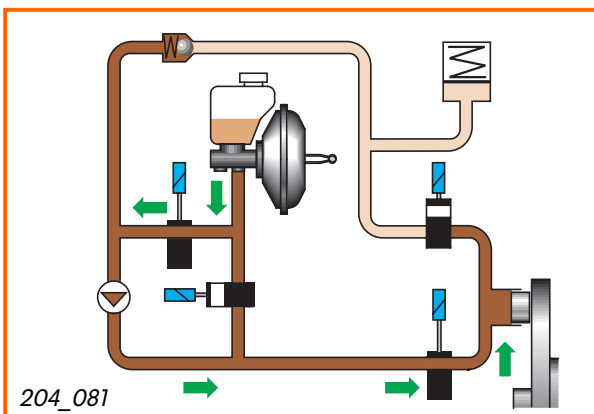

Increase pressure

The booster builds up a pre-pressure to enable the return flow pump to draw in the brake fluid. N225 closes, N227 opens. The intake valve remains open until the wheel has been braked to the extent required.

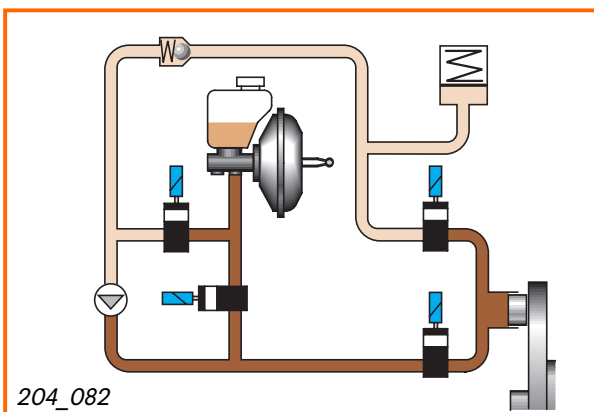

Hold pressure

All valves are closed.

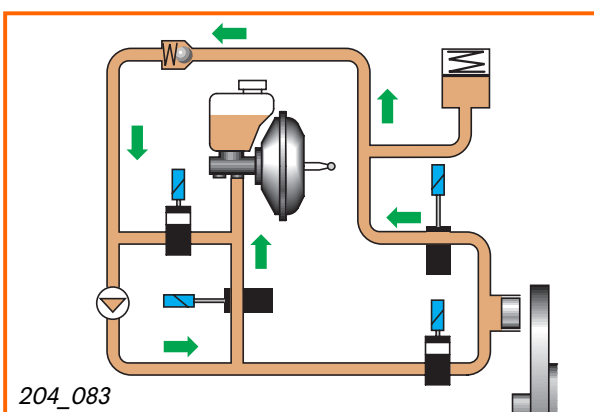

Reduce pressure

The exhaust valve is open, N225 is open or closed depending on pressure level. N227 and the intake valve are closed. Brake fluid is conveyed via N225 and the tandem master cylinders to the reservoir.

Functional diagram

ITT Automotive

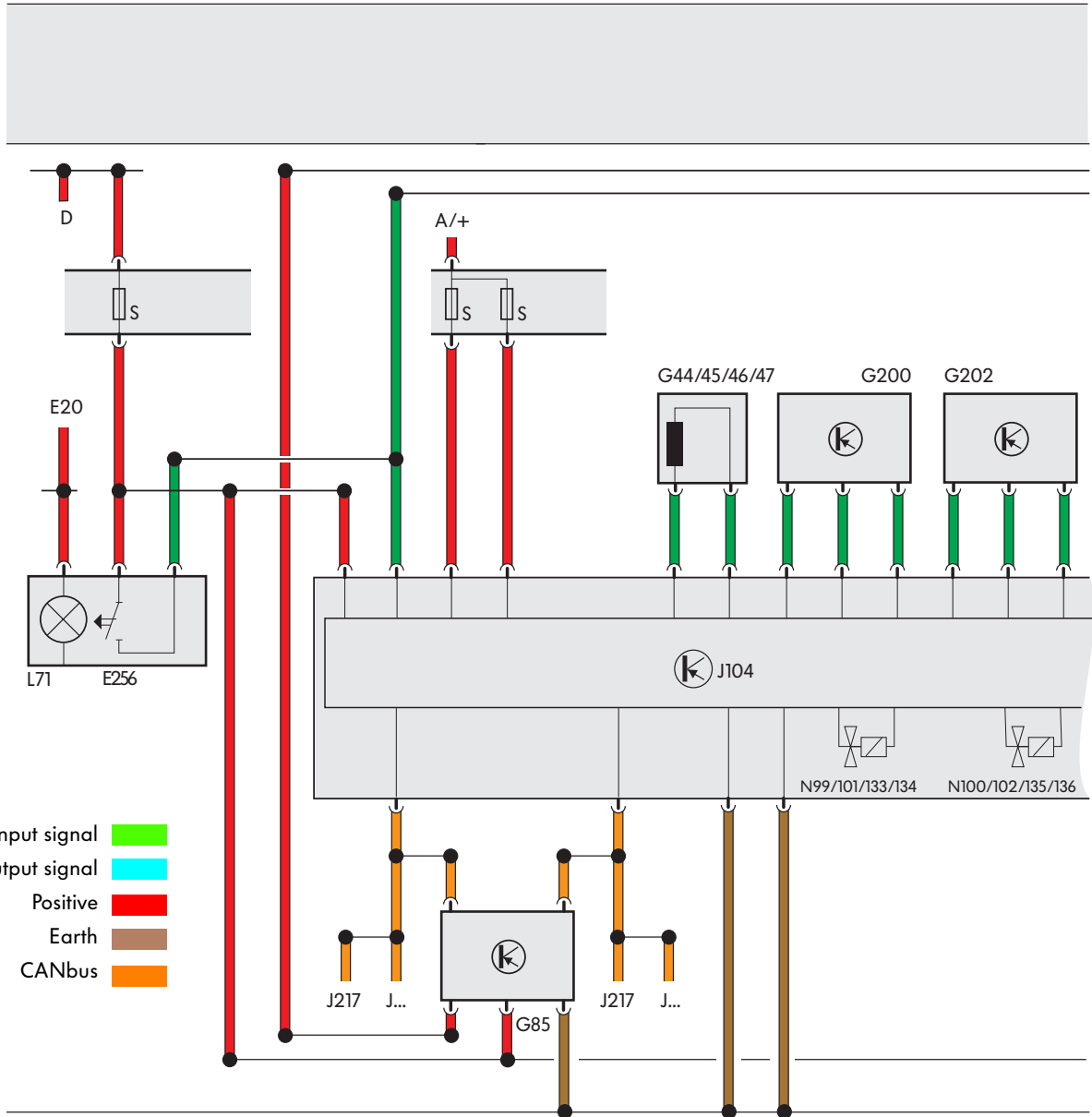

204_094

Components

A/+	Positive connection	G201	Brake pressure sender -1- at master brake cylinder
D	Ignition switch	G202	Yaw rate sender, in footwell on front left, in front of central control system for convenience system
E20	Controller for light switches and instruments	G214	Brake pressure sender -2-, at master brake cylinder
E256	Button for TCS/ESP	G249	Longitudinal acceleration sender in right-hand A pillar
F	Brake light switch	J...	Engine management control units
F9	Handbrake warning switch	J104	ABS control unit with EDL/TCS/ESP, in footwell on front right at engine bulkhead
F34	Brake fluid warning contact	J217	Control unit for auto. gearbox, in plenum chamber at centre
F83	ESP brake recognition switch, in the brake servo	J285	Control unit for display unit in dash panel insert
G44-47	Speed sensor	J401	Control unit for navigation system with CD-ROM drive
G85	Steering angle sender		
G200	Lateral acceleration sender		

Self-diagnosis

Self-diagnosis can be performed with fault readers V.A.G 1551 and V.A.G 1552.

The following functions are available:

- 00- Automatic test procedure,
- 01 - Interrogate control unit version,
- 02- Interrogate fault memory,
- 03 - Actuator diagnosis
- 04 - Initiate basic adjustment ,
- 05 - Erase fault memory,
- 06 - End of printout,
- 08 - Read measured value block and
- 11 - Login procedure.

The interface between the diagnostic unit and the ESP system is the diagnosis plug connection. The exact fitting location is dependent on the vehicle type.

Special features

The following display group numbers are available in Function 04 "Initiate basic adjustment":

- 60 - Zero adjust for steering angle sender,
- 63 - Zero adjust for lateral acceleration sender,
- 66 - Zero adjust for sensors for brake pressure and
- 69 - Zero adjust for longitudinal acceleration sender (only 4-wheel drive vehicles)

Zero adjust is necessary when one of the components is replaced.

For a detailed description of the procedure, please refer to the Golf 1998 Workshop Manual, the booklet entitled "Running gear self-diagnosis for ABS

Documented ABS systems: EDL, EBC, TCS, ESP".



Speed sensor faults

If at least once speed sensor is defective, the ABS warning lamp and the TCS/ESP warning lamp are switched on. The related systems are then deactivated.

The EBD function remains active.

If this speed sensor fault no longer occurs during the self-test or at a road speed of more than 20 kph, the warning lamps go off.

Warning lamps and buttons in the diagnosis

If a fault occurs while corrective intervention is in progress, the system tries its best to complete corrective intervention. At the end of the intervention process, the related subsystem is de-activated and the warning lamp is activated.

Faults and activation of warning lamps are always saved to fault memory.





















The ESP function can be de-activated by pressing the button for TCS/ESP.

Warning lamps

 Brake system warning lamp K118

 ABS warning lamp K47

 TCS/ESP warning lamp K155

	K118	K47	K155
Ignition "on" The lamps go off after approx. 3 s if system is OK			
System OK			
TCS/ESP intervention			
TCS/ESP failure or TCS/ESP button off ABS/EDL and EBD remain active.			
ABS/EDL failure All systems are shut down, EBD remains active e.g. only one speed sensor is defective.			
ABS/EDL and EBD failure All systems are shut down e.g. two or more speed sensors are defective.			
Brake fluid level too low All systems are active.			



Use of spare parts

Please bear in mind that some of the sensors, such as the yaw rate sender or lateral acceleration, are highly sensitive measuring instruments incorporating space technology.



Therefore:

- Transport spare parts in their original packaging and do not unpack them until shortly before they are due to be installed.
- Do not drop parts.
- Do not place heavy objects on the sensors.
- During installation, pay attention to the exact installation position.
- Make sure you observe the rules for cleanliness at the workplace.

Calibrating the sensors and sender

After replacing the steering angle sender G85 or control unit J104, the new sender must be calibrated. This means that the sensor must learn the straight-ahead position of the steering wheel.

For a detailed description of the procedure, please refer to the relevant Workshop Manual.

Please note that the yellow dot in the inspection glass at the base of the steering angle senders is fully visible. It indicates that the sensor is in the 0° CCS position.

After replacing the senders for pressure, lateral acceleration and (if applicable) longitudinal acceleration, these senders must also be calibrated using fault readers V.A.G 1551 and V.A.G 1552.

The yaw rate sender is calibrated automatically.



Test your knowledge

1. What statement on the longitudinal acceleration sender is true?

- a) It is only required on 4-wheel drive vehicles.
- b) It must always be at the vehicle's centre of gravity.
- c) If it is defective, the ESP and ABS functions are de-activated.
The EBD function remains active.

2. When is it appropriate to de-activate the ESP system?

- a) When freeing the vehicle from deep snow or a loose surface by rocking vehicle back and forth.
- b) on black ice.
- c) when driving with snow chains.
- d) when running the vehicle on a dynamometer.

3. What sensor signals to the ESP control unit that the vehicle has swerved?

- a) The steering angle sender.
- b) The lateral acceleration sender.
- c) The longitudinal acceleration sender.

4. The vehicle threatens to oversteer.

How does the ESP system re-stabilise the vehicle?

- a) Only by braking the front wheel on the inside of the corner.
- b) Only by braking the front wheel on the outside of the corner.
- c) By braking the front wheel on the outside of the corner and by intervening in the engine and gearbox management systems.
- c) By braking the front wheel on the inside of the corner and by intervening in the engine and gearbox management systems.

5. What system components are tested by the self-diagnosis.

- a) The hydraulic pump for driving dynamic control V156.
- b) The button for TCS/ESP E256.
- c) The yaw rate sender G202.
- d) The lateral acceleration sender G200.



Glossary

Force

is a directed physical parameter. It causes a freely movable body to change shape or accelerate.

A body on which no forces are acting remains in a state of rest or constant linear movement. A body is therefore in a state of rest when the total of all forces acting on it equals zero.

The SI units of force are Newtons (N),
 $1\text{N} = 1\text{m} \cdot \text{kg}/\text{s}^2$.

Acceleration

is a change of speed in the units of time according to quantity or direction.

The unit of acceleration is m/s^2 .

In the case of a linear movement, acceleration involves an increase or decrease in velocity (negative acceleration, deceleration, braking).

Torque or moment

is generally a quantity, e.g. force, pulse, charge, mass or area, which is multiplied by a distance (e.g. lever) or distance squared. Example: torque, pulse moment, moment of inertia, magnetic moment.

Pressure

is defined as a force f ; $p=f/a$ acts on a unit of area a .

The units of pressure are Pascal (Pa), bar (1 bar = 10^5 Pa), $1\text{Pa} = \text{N}/\text{m}^2 = \text{J}/\text{m}^3$. The previously common units of kp/m^2 , psi and Torr are no longer used. The pressure of a gas in a vessel is determined by the force which induces a change in movement of the gas molecules when they collide with the walls of the vessel.

Capacitance

The measure (C) of electrical charge defined as the relationship between a quantity of charge (Q) to a voltage (V) where

$$C=Q/U. 1\text{F} = \text{A}^2 \cdot \text{s}^4/\text{kg} \cdot \text{m}^2 = \text{A} \cdot \text{s}^2/\text{V} = \text{C}/\text{V}.$$

Capacitance is dependent on the geometric layout of the conductor and the dielectric constant of the material in which the conductors are located. Two metal plates which are separated by a narrow gap are known as capacitors.

Coriolis acceleration

Named after the French physicist Gustav-Gaspard Coriolis, 1792 - 1843.

The effect of the Coriolis force is an apparent deflection of the path of an object that moves within a rotating coordinate system. The object does not actually deviate from its path, but it appears to do so because of the motion of the co-ordinate system.

The Coriolis effect is most apparent in the path of an object moving longitudinally. On the Earth an object that moves along a north-south path, or longitudinal line, will undergo apparent deflection to the right in the Northern Hemisphere and to the left in the Southern Hemisphere. If the co-ordinate system is referred to as the reference frame, only an observer within the reference frame can observe this phenomenon.



Coulomb

Charles-Augustin de Coulomb, French physicist and engineer, 14.06.1736 - 23.08.1806.

The unit of electric charge Q bears his name.

$1C = A \cdot s$ in SI basic units

Newton

Sir Isaac Newton, English physicist and mathematician, 04.01.1643 - 31.03.1727.

His publications, which had a seminal influence on physical and astronomical research, include the "Philosophiæ naturalis principia mathematica" (1687, Mathematical Principles of Natural Philosophy). Together with the principles of mechanics, they are the foundation on which classical theoretical physics is based.

Newton assumed an absolute view of space, time and motion. Since Mach, Lorentz, Poincaré and Einstein, a relativistic view of space, time and motion contrary to Newton's theory has become generally accepted.

Faraday

Michael, Engl. physicist and chemist, 22.09.1791 - 25.08.1867.

Faraday discovered electromagnetic induction and defined the basic laws of electrolysis, among other things.

The unit of electrical capacitance is named after him: 1 farad [F] = $1C/V$.

SI units

SI is the abbreviation for "Système International d'Unités" (International System of Units). It comprises seven basic units from which all other physical and chemical units can be derived.

The basic units are:

Length	metres	[m]
Mass	kilogrammes	[kg]
Time	seconds	[s]
Electrical current intensity	Ampere	[A]
Thermodynamic temperature	Kelvin	[K]
Amount of substance	Mol	[mol]
Luminous intensity	Candela	[cd]

5. a), c), d)
4. c)
3. b)
2. a), c), d)
1. a), c)

Solutions



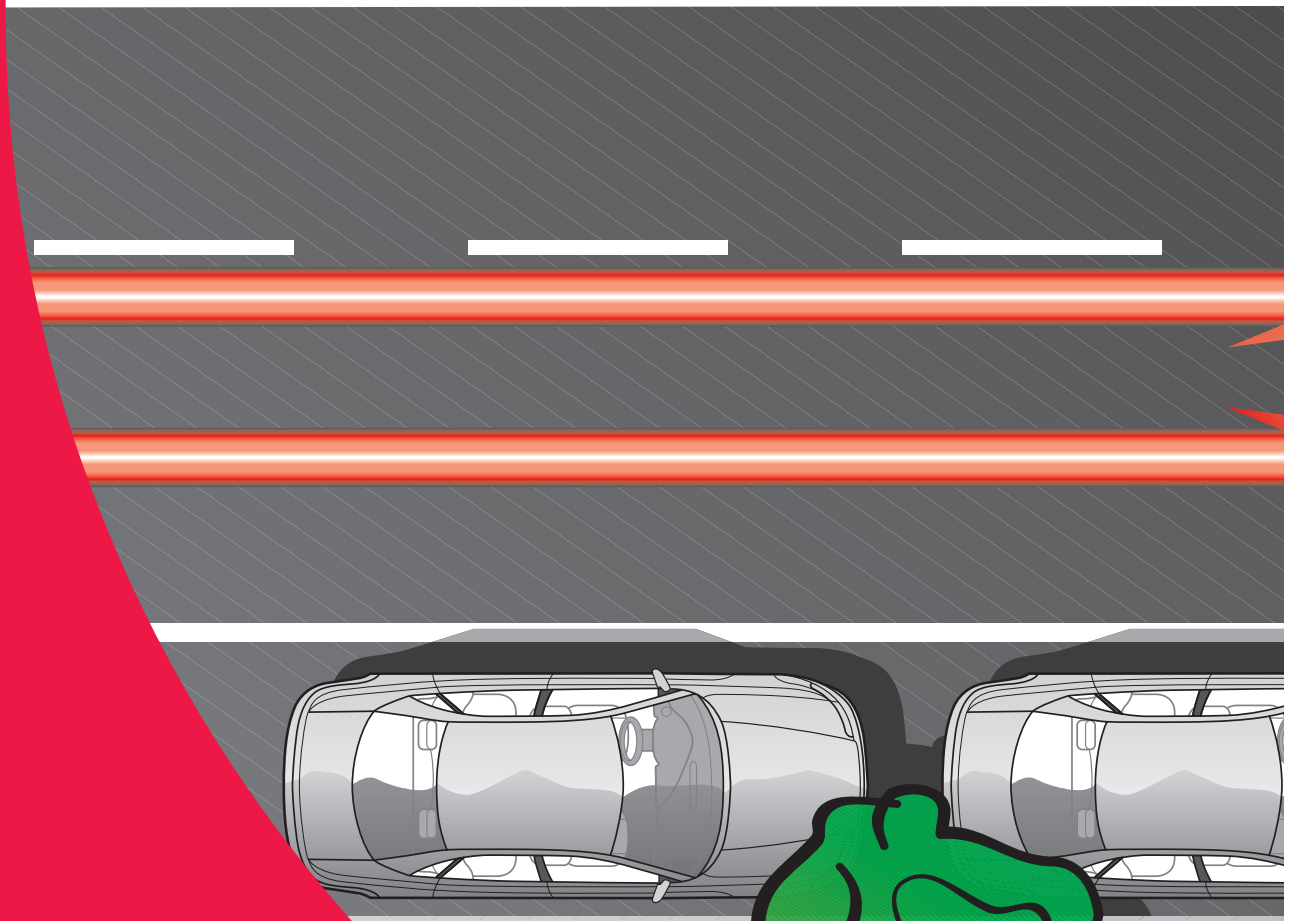

For internal use only. © VOLKSWAGEN AG, Wolfsburg

All rights reserved. Technical specifications subject to change without notice.

840.2810.23.20 Technical status: 07/98

 This paper is produced from
non-chlorine-bleached pulp.