



2AZ-FE 排气

排气管

组件	EX-1
拆卸	EX-2
安装	EX-3



排气管 组件

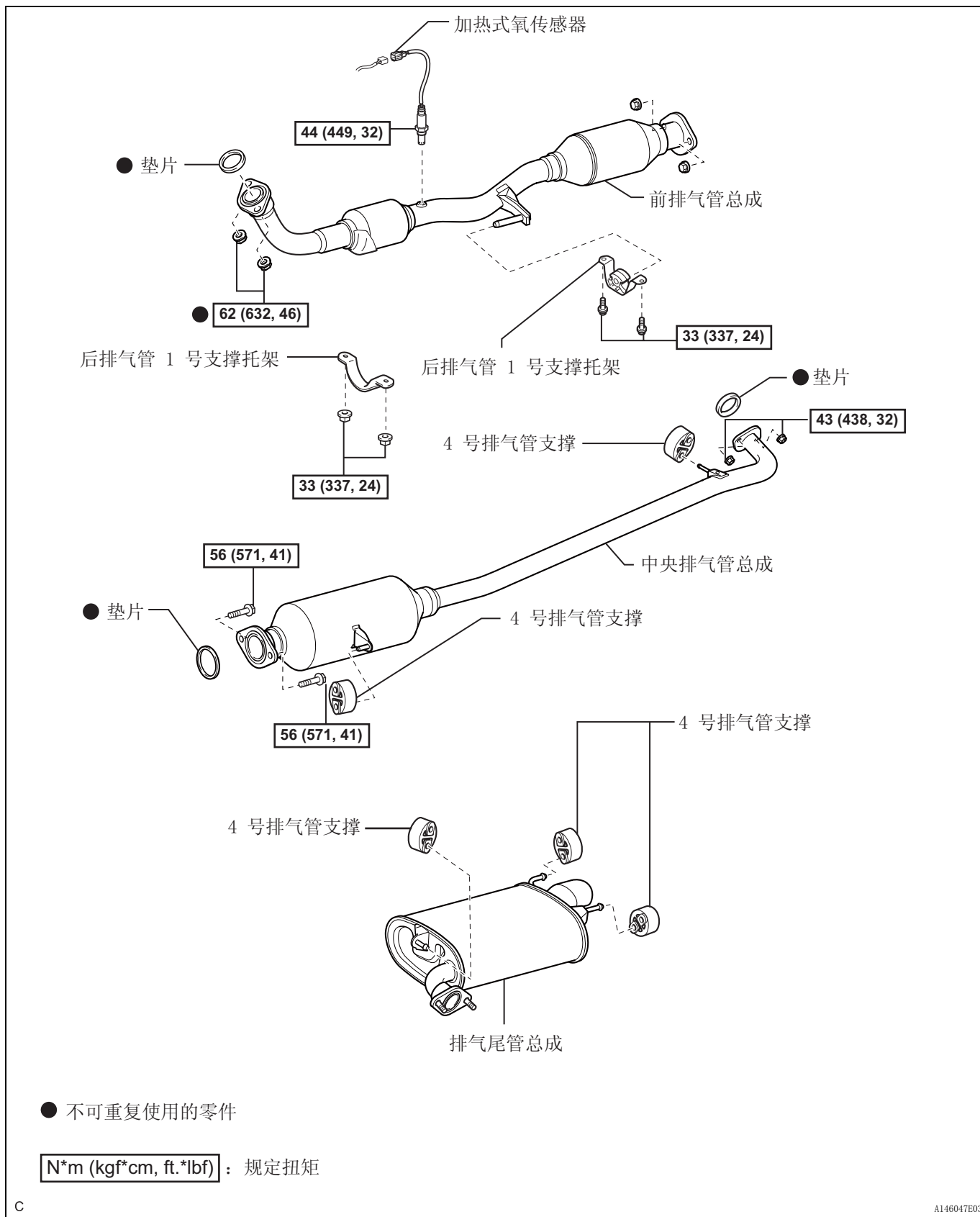

EX

拆卸

1. 拆卸排气尾管总成

(a) 拆卸 2 个螺母和排气尾管总成。

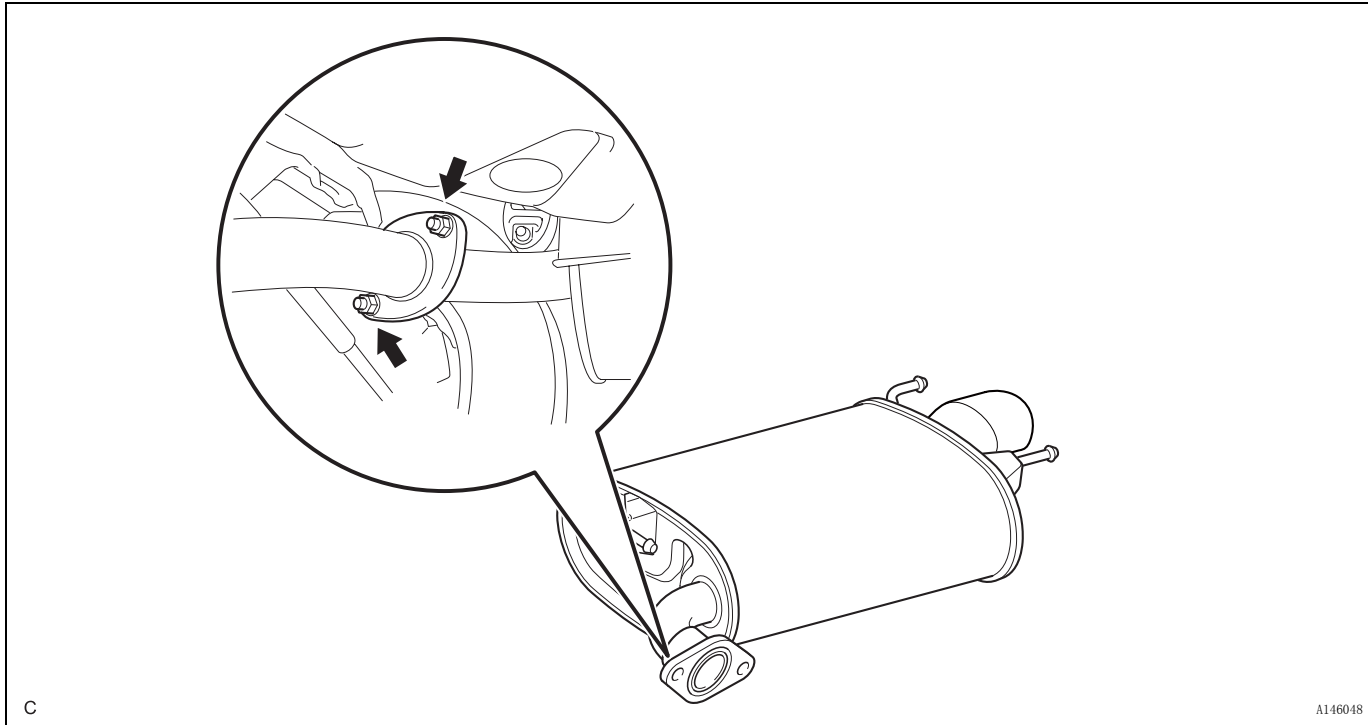

(b) 从中央排气管上拆卸垫片。

2. 拆卸中央排气管总成

(a) 拆卸 2 个螺栓、2 个螺母和中央排气管总成。

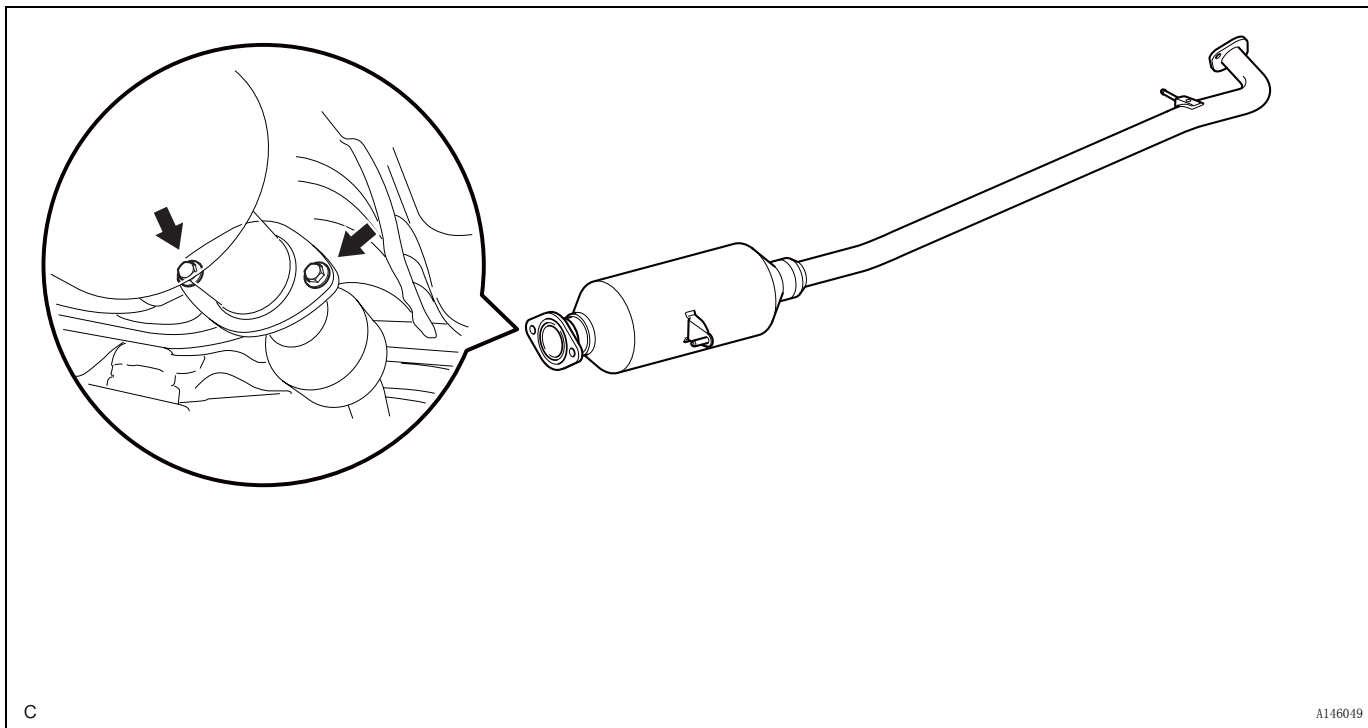

(b) 从前排气管上拆卸垫片。

3. 拆卸加热式氧传感器（参见页次 EC-20）

4. 拆卸前排气管总成

- (a) 拆卸 4 个螺母、前排气管 1 号支撑托架和前排气管总成。

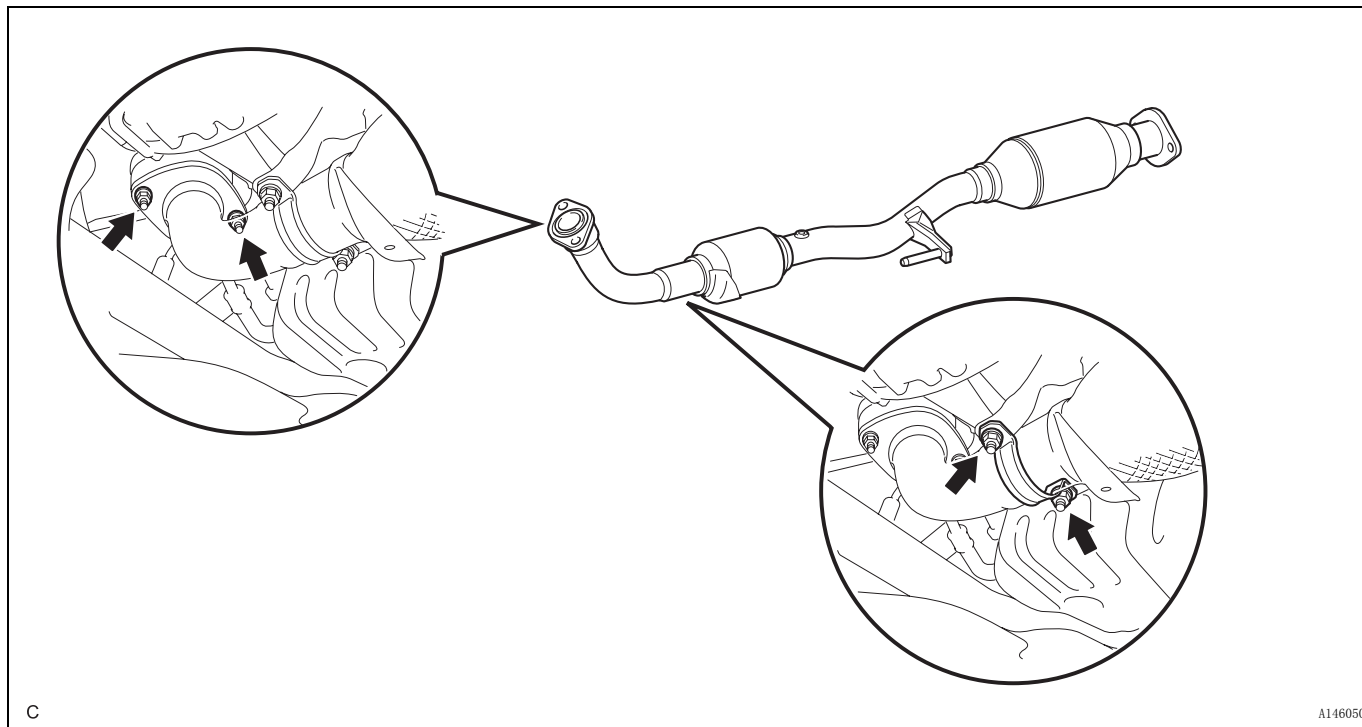

- (b) 从前排气管上拆卸垫片。

5. 拆卸后排气管 1 号支撑托架

- (a) 拆卸 2 个螺栓和后支撑托架。

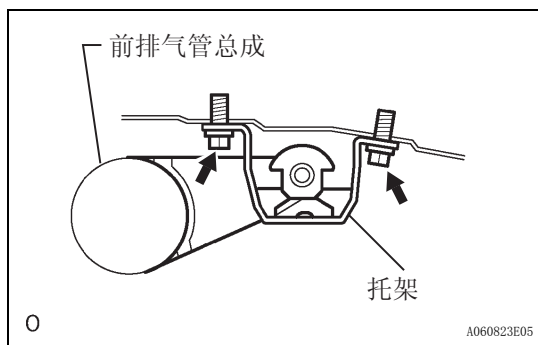
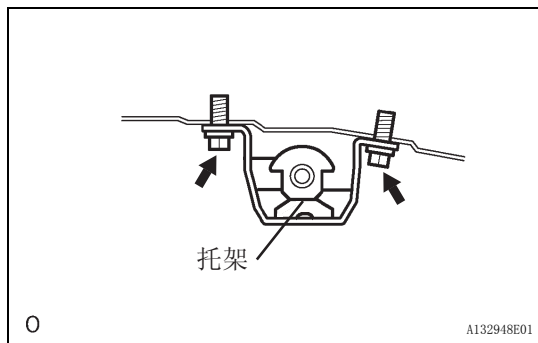

安装

1. 安装后排气管 1 号支撑托架

- (a) 用 2 个螺栓安装后支撑托架。

扭矩：33 N*m (337 kgf*cm, 24 ft.*lbf)

备注：

确保安装托架时使其朝向正确的方向。

2. 安装加热式氧传感器（参见页次 EC-20）

3. 安装前排气管总成

- (a) 将新垫片安装到前排气管总成上。

EX-4

2AZ-FE 排气 - 排气管

- (b) 用 2 个新螺母安装前排气管总成。
扭矩： 62 N*m (632 kgf*cm, 46 ft.*lbf)

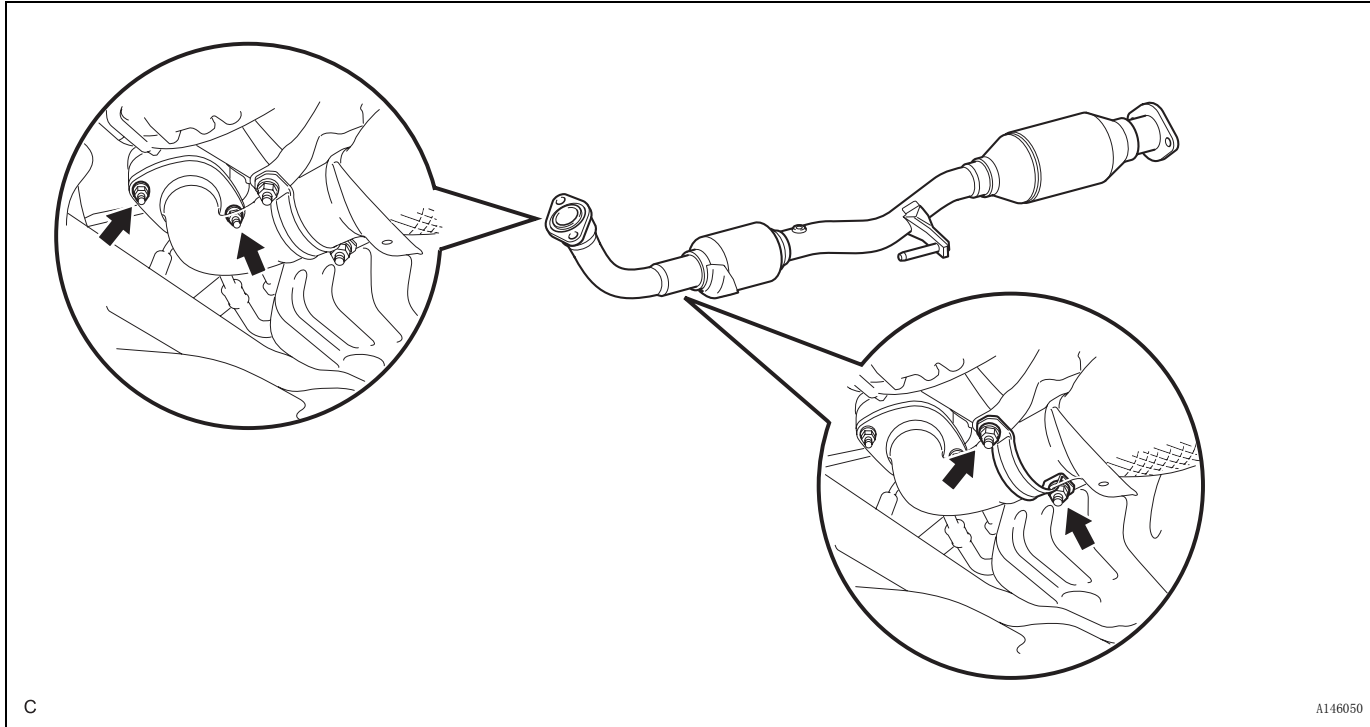

- (c) 用 2 个螺母安装前排气管 1 号支撑托架。
扭矩： 33 N*m (337 kgf*cm, 24 ft.*lbf)

4. 安装中央排气管总成

- (a) 将新垫片安装到前排气管上。
(b) 用 2 个螺栓和 2 个螺母安装中央排气管总成。

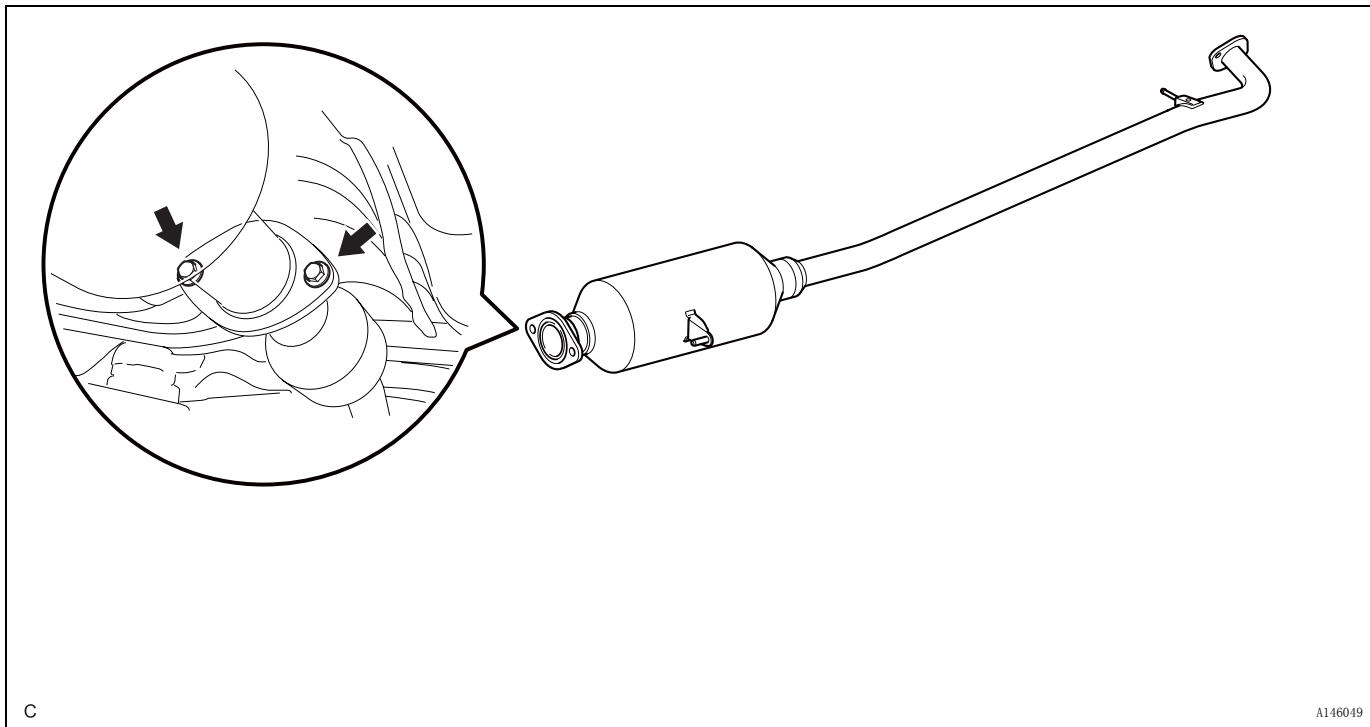

EX

扭矩： 56 N*m (571 kgf*cm, 41 ft.*lbf)

5. 安装排气尾管总成

- (a) 将新垫片安装到中央排气管总成上。
- (b) 用 2 个螺母安装排气尾管总成。

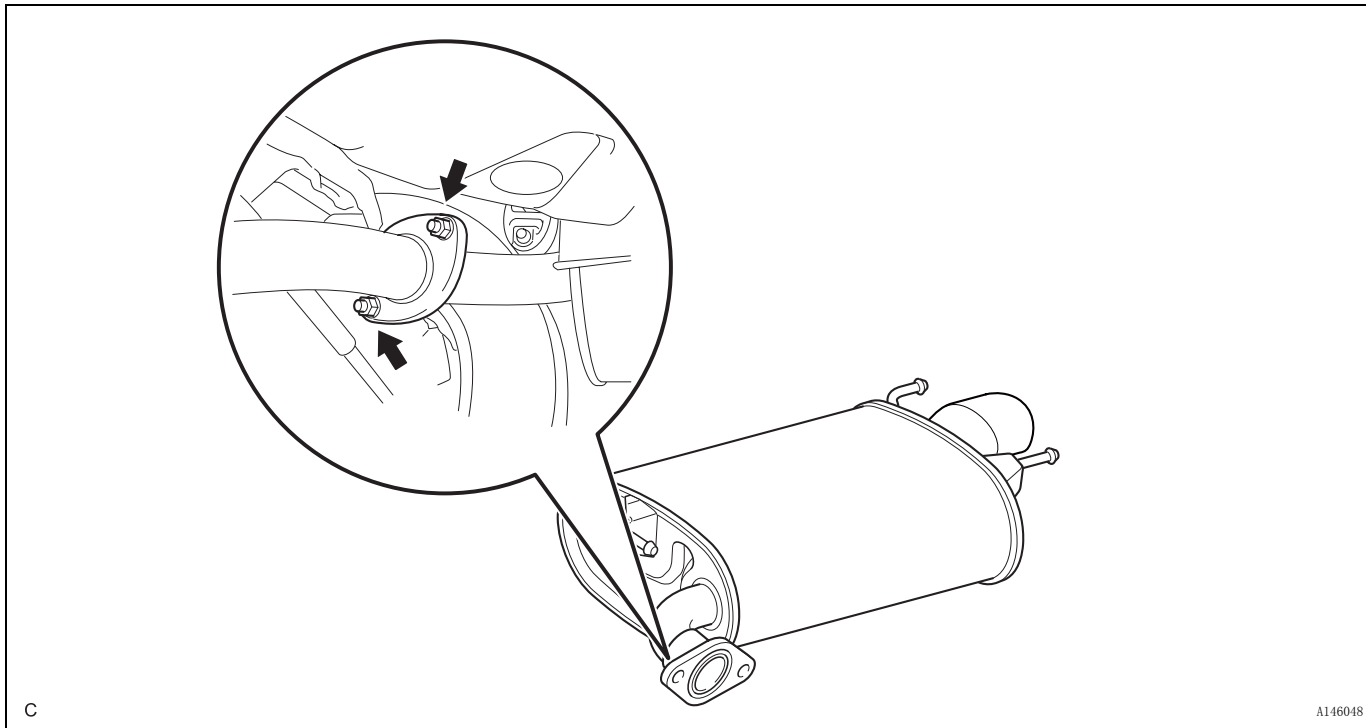

扭矩： 43 N*m (438 kgf*cm, 32 ft.*lbf)

6. 检查有无废气泄漏

如有废气泄漏，拧紧必要的部位以阻止泄漏。如有必要，更换损坏的零件。



- 备忘录 -

