

REMOVAL

1. **DISCONNECT CABLE FROM NEGATIVE BATTERY TERMINAL**

CAUTION:

Wait at least 90 seconds after disconnecting the cable from the negative (-) battery terminal to prevent airbag and seat belt pretensioner activation.

2. **REMOVE SHIFT LEVER KNOB SUB-ASSEMBLY**
3. **REMOVE REAR CONSOLE BOX SUB-ASSEMBLY**
 - (a) Remove the console box (see page [IP-20](#)).
4. **DISCONNECT TRANSMISSION CONTROL CABLE ASSEMBLY**

- (a) Disconnect the control cable from the shift lever.

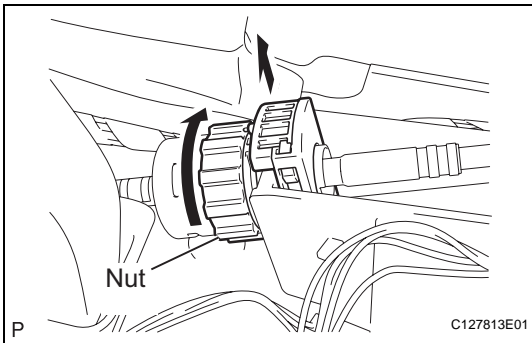
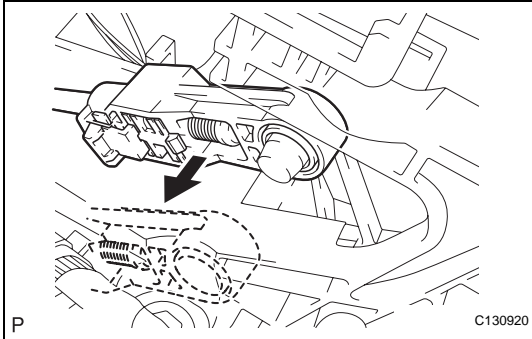

- (b) Turn the nut and disconnect the control cable from the shift lever retainer.

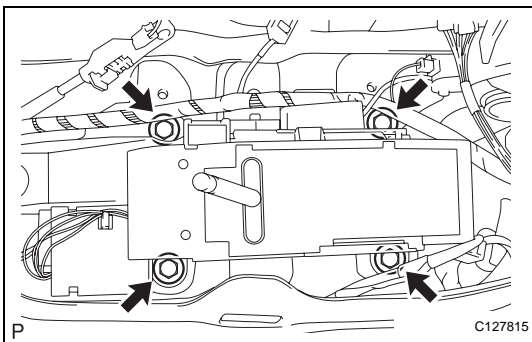

5. **REMOVE FLOOR SHIFT ASSEMBLY**
 - (a) Remove the 4 bolts and floor shift.

- (b) Disconnect the 2 connectors and detach the clamp.

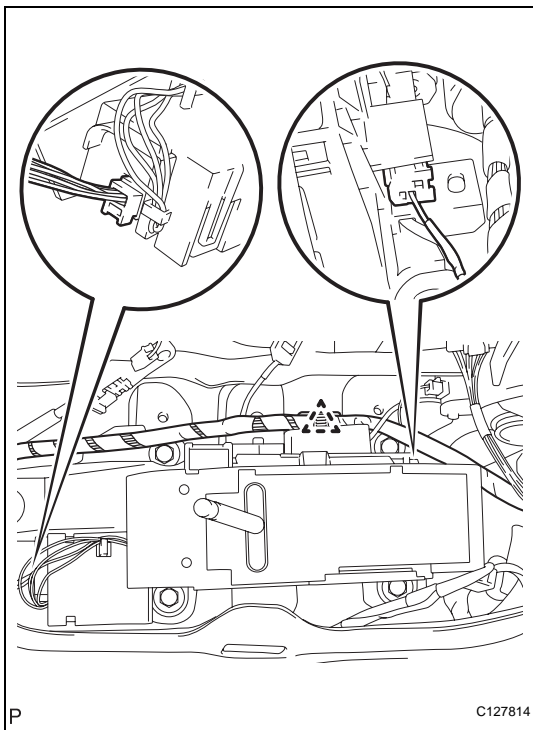

DISASSEMBLY

1. **REMOVE LOWER POSITION INDICATOR HOUSING**
 - (a) Detach the 4 claws and remove the housing.
 - (b) Remove the position indicator slide cover with slide No. 2 cover.

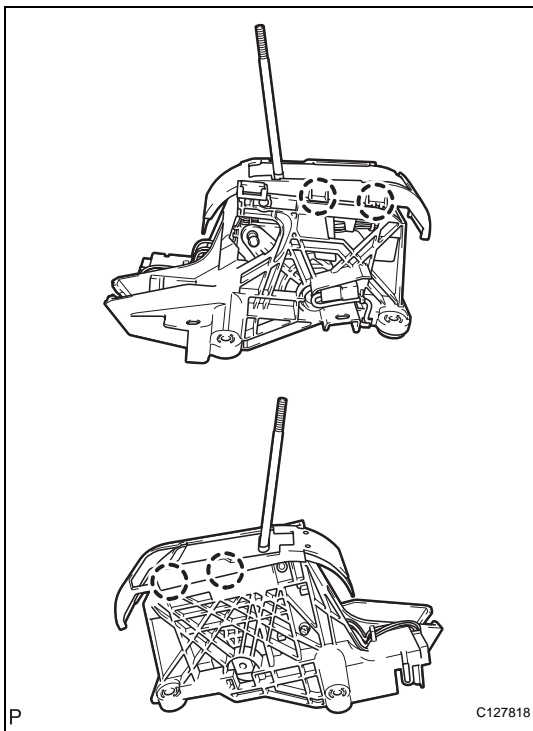

2. **REMOVE POSITION INDICATOR LIGHT HOUSING**
 - (a) Detach the 2 claws and remove the indicator light housing from the floor shift position indicator housing.
3. **REMOVE INDICATOR LIGHT WIRE SUB-ASSEMBLY**

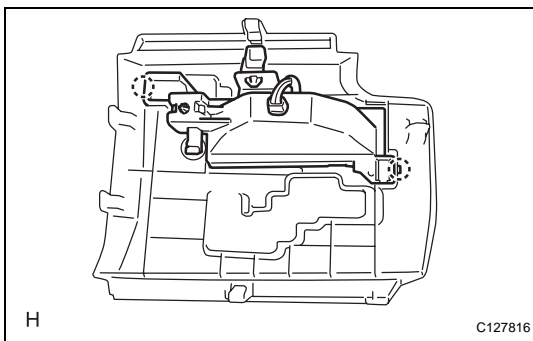

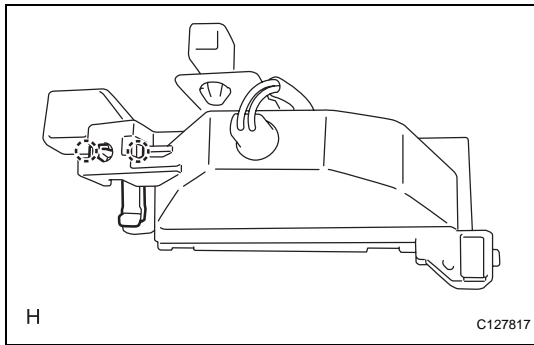

- 4. REMOVE SHIFT LOCK RELEASE BUTTON**
- (a) Detach the 2 claws and remove the button and spring from the position indicator light housing.

AX