

DTC	P0778	Pressure Control Solenoid "B" Electrical (Shift Solenoid Valve SL2)
------------	--------------	----------------------------------------------------------------------------

DESCRIPTION

Shifting from 1st to O/D is performed in combination with the ON and OFF operation of the shift solenoid valves SL1 and SL2, which are controlled by the ECM. If an open or short circuit occurs in any of the shift solenoid valves, the ECM controls the remaining normal shift solenoid valves to allow the vehicle to be operated safely (see page [AX-31](#)).

DTC No.	DTC Detection Condition	Trouble Area
P0778	Duty cycle to shift solenoid valve SL2 is 100% (1 trip detection logic)	<ul style="list-style-type: none"> • Open or short in shift solenoid valve SL2 circuit • Shift solenoid valve SL2 • ECM

MONITOR DESCRIPTION

This DTC indicates an open or short in the shift solenoid valve SL2 circuit. The ECM commands gear shifts by turning the shift solenoid valves ON/OFF. When there is an open or short circuit in any shift solenoid valve circuit, the ECM detects the problem, illuminates the MIL and stores the DTC. Also, the ECM performs the fail-safe function and turns the other normal shift solenoid valves ON/OFF. In case of an open or short circuit, the ECM stops sending current to the circuit (see page [AX-31](#)).

MONITOR STRATEGY

Related DTCs	P0778: Shift solenoid valve SL2/Range check
Required sensors/Components	Shift solenoid valve SL2
Frequency of operation	Continuous
Duration	1 sec.
MIL operation	Immediate
Sequence of operation	None

TYPICAL ENABLING CONDITIONS

The monitor will run whenever this DTC is not present.	None
Battery voltage	11 V or more
Starter	OFF
Ignition switch	ON

TYPICAL MALFUNCTION THRESHOLDS

Solenoid status	Fail
-----------------	------

COMPONENT OPERATING RANGE

Output signal duty	Less than 100%
--------------------	----------------

WIRING DIAGRAM

AX

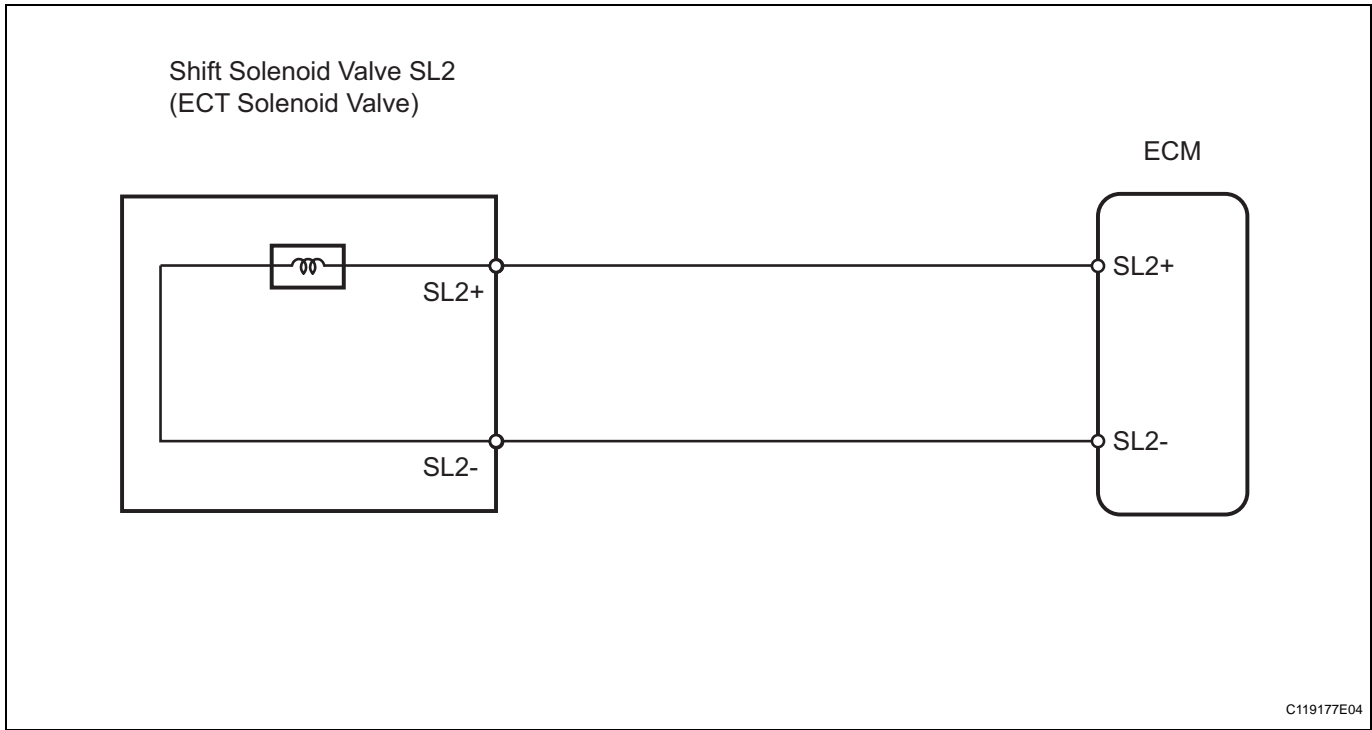

INSPECTION PROCEDURE

1 INSPECT TRANSMISSION WIRE (SHIFT SOLENOID VALVE SL2)

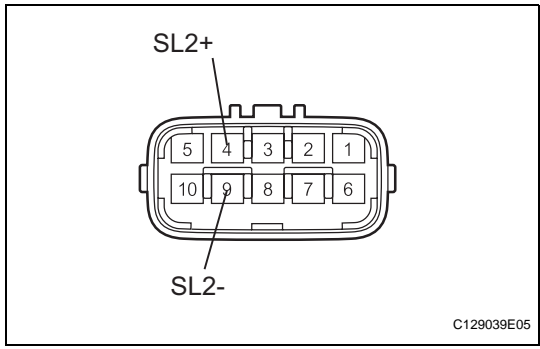

- (a) Disconnect the B27 wire connector.
- (b) Measure the resistance of the transmission wire.

Standard resistance

Tester Connection	Condition	Specified Condition
4 (SL2+) - 9 (SL2-)	20°C (68°F)	5.0 to 5.6 Ω
4 (SL2+) - Body ground	20°C (68°F)	1 MΩ or higher
9 (SL2-) - Body ground	20°C (68°F)	1 MΩ or higher

OK

NG

Go to step 3

2 CHECK WIRE HARNESS (TRANSMISSION WIRE - ECM)

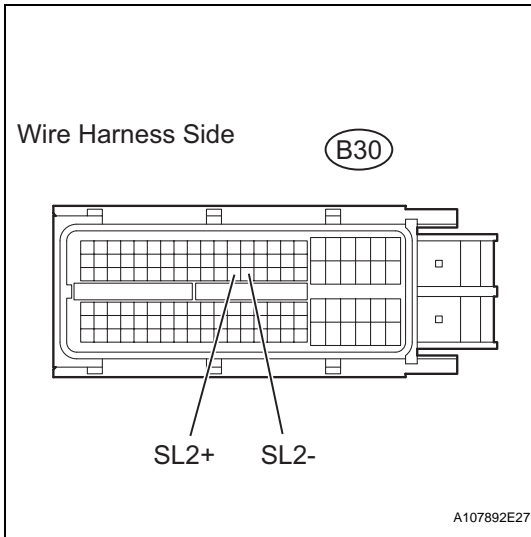

- (a) Disconnect the B30 ECM connector.
- (b) Measure the resistance of the wire harness side connector.

Standard resistance

Tester Connection	Condition	Specified Condition
B30-58 (SL2+) - B30-59 (SL2-)	20°C (68°F)	5.0 to 5.6 Ω
B30-58 (SL2+) - Body ground	20°C (68°F)	1 MΩ or higher
B30-59 (SL2-) - Body ground	20°C (68°F)	1 MΩ or higher

NG → **REPAIR OR REPLACE HARNESS AND CONNECTOR**

OK

REPLACE ECM

3 INSPECT SHIFT SOLENOID VALVE SL2

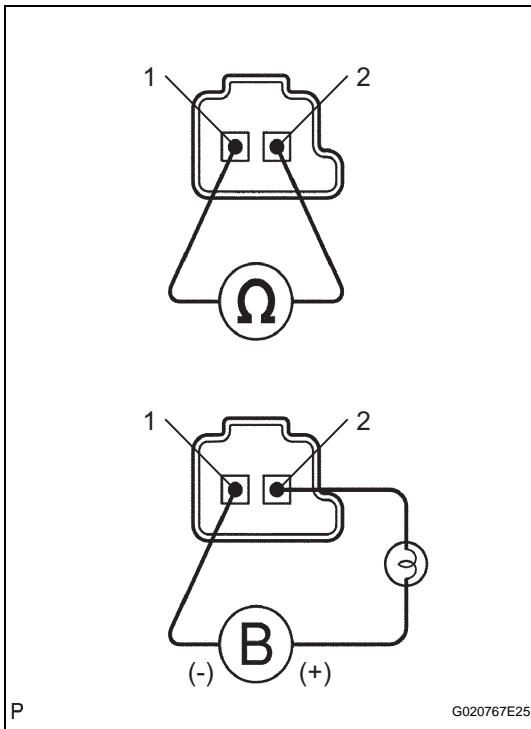

- (a) Remove the shift solenoid valve SL2.
 - (b) Measure the resistance of the solenoid valve.
- Standard resistance:**
5.0 to 5.6 Ω at 20°C (68°F)
- (c) Connect the battery's positive (+) lead with a 21 W bulb to terminal 2 and the negative (-) lead to terminal 1 of the solenoid valve connector. Then check that the valve moves and makes an operating noise.

OK:
 Valve moves and makes operating noise.

NG → **REPLACE SHIFT SOLENOID VALVE SL2**

OK

REPAIR OR REPLACE TRANSMISSION WIRE