

AX

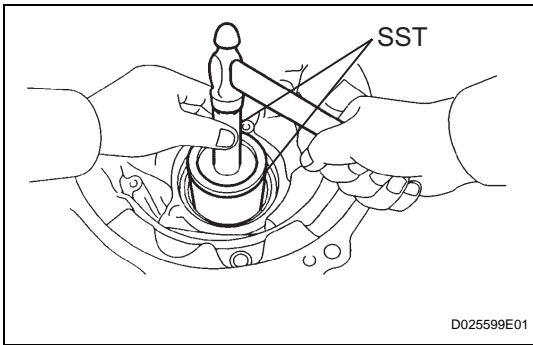

7. REMOVE TRANSAXLE HOUSING OIL SEAL

- (a) Using SST and a hammer, tap out the oil seal.
SST 09950-70010 (09951-07100), 09215-00013 (09215-00471)

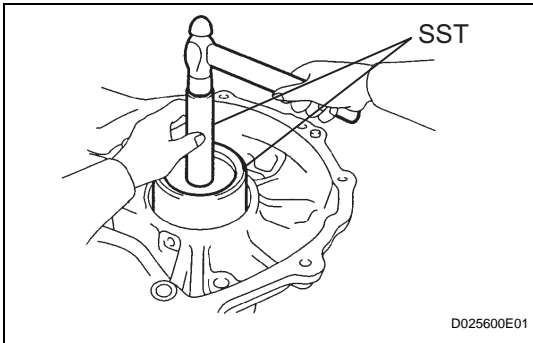

8. REMOVE DIFFERENTIAL SIDE BEARING RETAINER OIL SEAL

- (a) Using SST and a hammer, tap out the oil seal.
SST 09950-70010 (09951-07100), 09608-10010

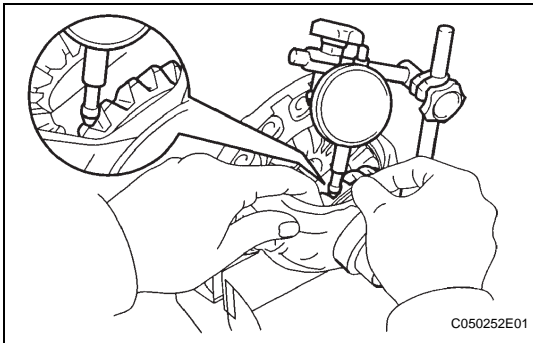

INSPECTION

1. INSPECT DIFFERENTIAL SIDE GEAR BACKLASH

- (a) Using a dial indicator, measure the backlash of the side gear.
Standard backlash:
0.05 to 0.20 mm (0.0020 to 0.0070 in.)
Standard thrust washer thickness:
1.625 mm (0.0640 in.)
1.725 mm (0.0679 in.)
1.825 mm (0.0719 in.)

REASSEMBLY

1. INSTALL FRONT DIFFERENTIAL SIDE GEAR

- (a) Coat the 2 front differential side gears, 2 side gear thrust washers, 2 front differential pinions and 2 pinion thrust washers with ATF and install them to the differential case.

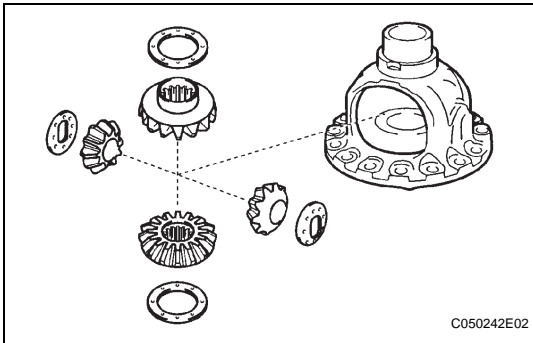

2. INSTALL NO. 1 FRONT DIFFERENTIAL PINION SHAFT

- (a) Coat the No. 1 front differential pinion shaft with ATF, and install it to the differential case.

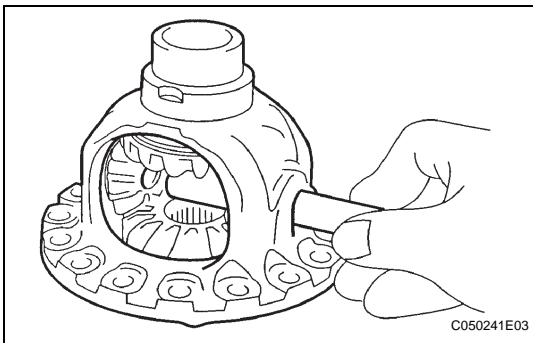

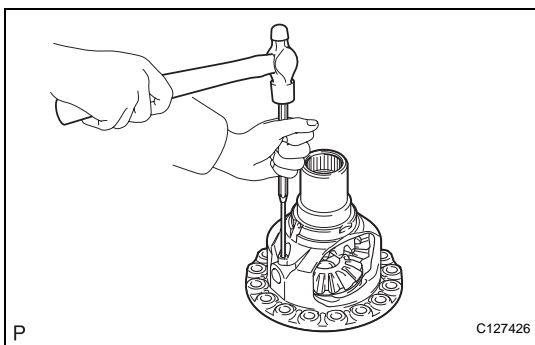

3. INSTALL FRONT DIFFERENTIAL PINION SHAFT STRAIGHT PIN

- (a) Using a pin punch and a hammer, tap in the pinion shaft straight pin.

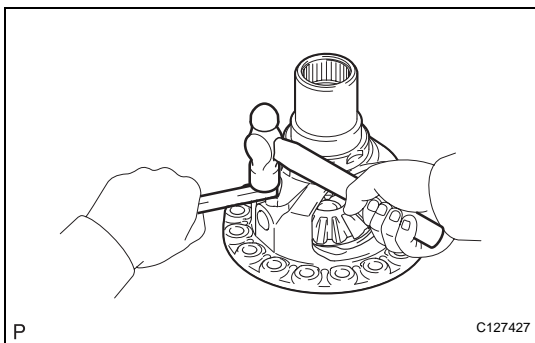

- (b) Using a chisel and a hammer, stake the differential case.

NOTICE:

Stake it after adjusting the backlash.

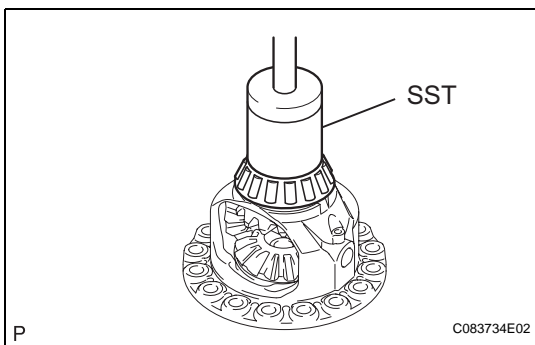

4. INSTALL FRONT DIFFERENTIAL CASE REAR TAPERED ROLLER BEARING

- (a) Using SST and a press, press in the front differential case rear tapered roller bearing to the differential case.

SST 09550-60010, 09950-60020 (09951-00680), 09950-70010 (09951-07100)

NOTICE:

- When replacing the bearing, be sure to replace it together with the outer race.
- When replacing a bearing of the differential case, replace both the front and rear bearings together.

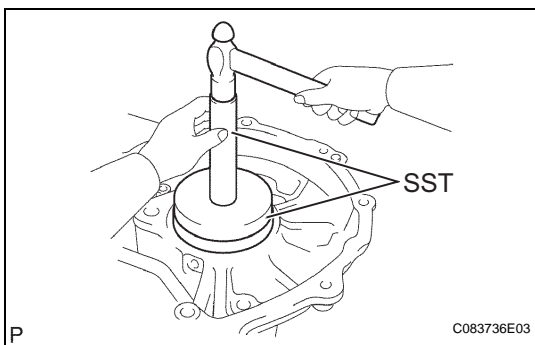

- (b) Using SST and a hammer, tap in the front differential case rear tapered roller bearing outer race to the transaxle housing.

SST 09550-60010, 09950-60020 (09951-00680), 09950-70010 (09951-07100, 09951-00890)

NOTICE:

When replacing the bearing, be sure to replace it together with the outer race.

AX

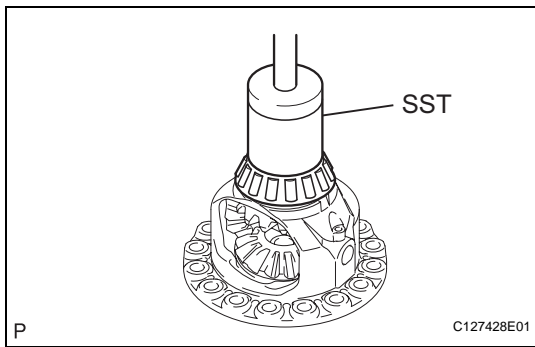

5. INSTALL FRONT DIFFERENTIAL CASE FRONT TAPERED ROLLER BEARING

- (a) Using SST and a press, press in the front differential case front tapered roller bearing to the differential case.

SST 09550-60010, 09950-60020 (09951-00680), 09950-70010 (09951-07100, 09951-00890)

NOTICE:

- When replacing the bearing, be sure to replace it together with the outer race.
- When replacing a bearing of the differential case, replace both the front and rear bearings together.

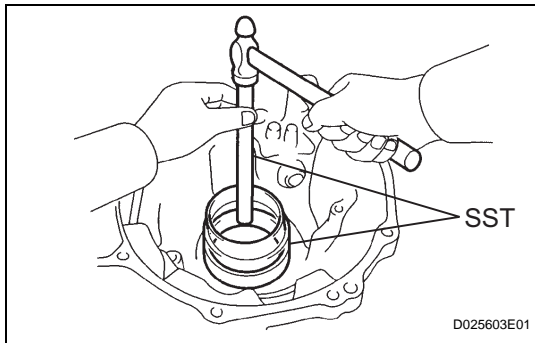

- (b) Using SST and a hammer, tap in the front differential case front tapered roller bearing outer race to the transaxle housing.

SST 09550-60010, 09950-60020 (09951-00680), 09950-70010 (09951-07100, 09951-00890)

NOTICE:

- When replacing the bearing, be sure to replace it together with the outer race.
- Clearance is not allowed between the bearing and transaxle housing.

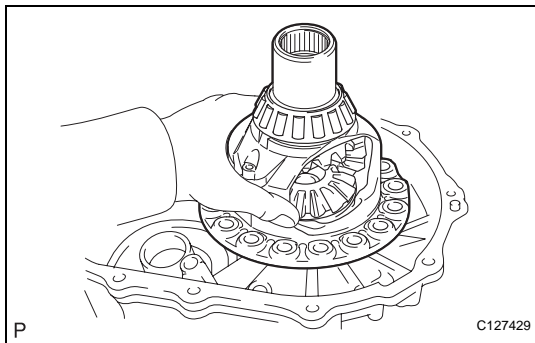

6. ADJUST DIFFERENTIAL SIDE BEARING PRELOAD

- (a) Install the differential assembly to the transaxle case.

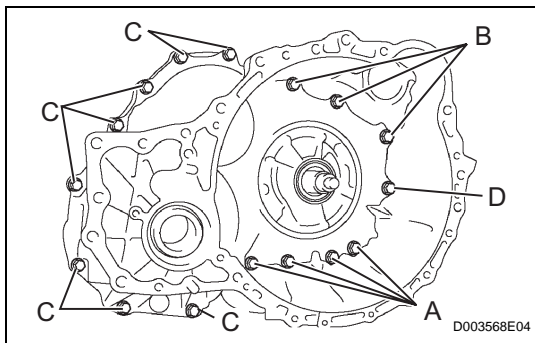

- (b) Clean the matching surfaces of the transaxle case and transaxle housing.

- (c) Install the transaxle housing to the transaxle case and tighten them with the 16 bolts.

**Torque: 22 N*m (224 kgf*cm, 16 ft.*lbf) for bolt A
 29 N*m (295 kgf*cm, 21 ft.*lbf) for bolt B
 29 N*m (295 kgf*cm, 21 ft.*lbf) for bolt C
 22 N*m (224 kgf*cm, 16 ft.*lbf) for bolt D**

HINT:

- Each bolt length is indicated below.

Bolt length:

- 50 mm (1.97 in.) for bolt A
- 50 mm (1.97 in.) for bolt B
- 42 mm (1.65 in.) for bolt C
- 72 mm (2.84 in.) for bolt D

- Usually, bolt A is a non-reusable bolt. In this case, however, it can be used after cleaning it.

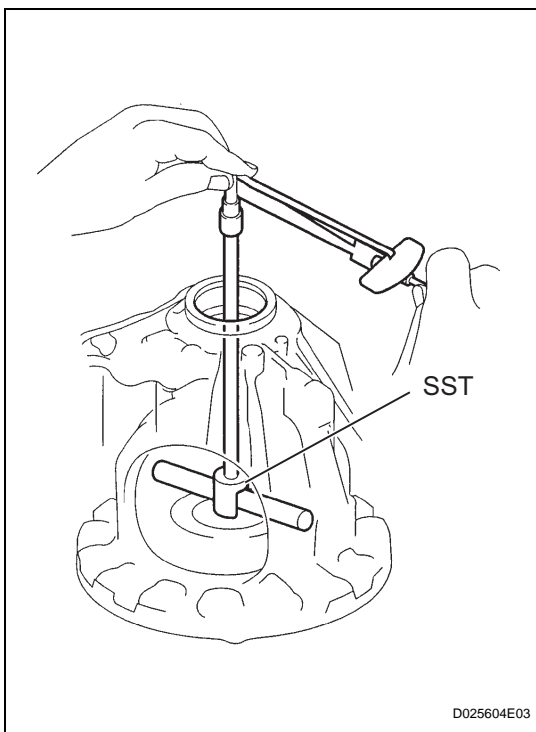

- (d) Using SST, turn the differential assembly right and left 2 or 3 times to allow the bearing to settle.

SST 09564-32011

- (e) Using SST and a torque wrench, measure the turning torque of the differential.

SST 09564-32011

**Torque: Standard turning torque at 60 rpm
0.20 to 0.69 N*m (2.0 to 7.0 kgf*cm, 1.8 to 6.1 in.*lbf)**

HINT:

If the turning torque is not within the specified value, refer to the table below and select a thrust washer so that the turning torque is within the specified value.

Flange thickness

Mark	Thickness	Mark	Thickness
0	2.00 mm (0.0787 in.)	J	2.025 mm (0.07972 in.)
1	2.05 mm (0.0807 in.)	K	2.075 mm (0.08169 in.)
2	2.10 mm (0.0827 in.)	L	2.125 mm (0.08366 in.)
3	2.15 mm (0.0846 in.)	M	2.175 mm (0.08563 in.)
4	2.20 mm (0.0866 in.)	N	2.225 mm (0.08760 in.)
5	2.25 mm (0.0886 in.)	P	2.275 mm (0.08957 in.)
6	2.30 mm (0.0906 in.)	Q	2.325 mm (0.09154 in.)
7	2.35 mm (0.0925 in.)	R	2.375 mm (0.09350 in.)
8	2.40 mm (0.0945 in.)	S	2.425 mm (0.09547 in.)
9	2.45 mm (0.0965 in.)	T	2.475 mm (0.09744 in.)
A	2.50 mm (0.0984 in.)	U	2.525 mm (0.09941 in.)
B	2.55 mm (0.1004 in.)	V	2.575 mm (0.10138 in.)
C	2.60 mm (0.1024 in.)	W	2.625 mm (0.10335 in.)
D	2.65 mm (1.1043 in.)	X	2.675 mm (0.10531 in.)
E	2.70 mm (0.1063 in.)	Y	2.725 mm (0.10728 in.)
F	2.75 mm (0.1083 in.)	AA	2.775 mm (0.10925 in.)
G	2.80 mm (0.1102 in.)	AB	2.825 mm (0.11122 in.)
H	2.85 mm (0.1122 in.)	-	-

AX

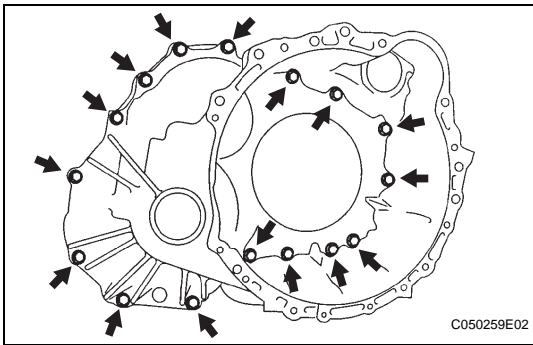

(f) Remove the 16 bolts and the transaxle housing.

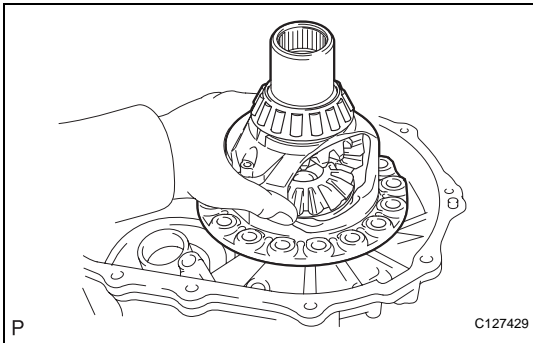

(g) Remove the differential assembly.

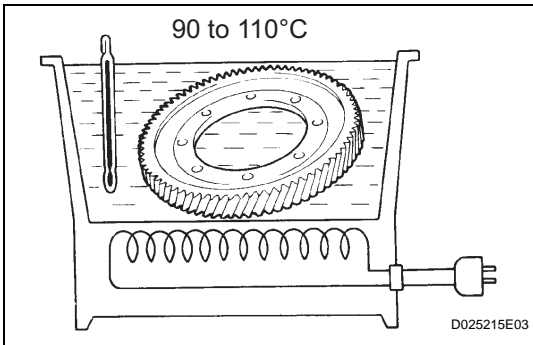

7. INSTALL FRONT DIFFERENTIAL RING GEAR

(a) Using ATF and a heater, heat the front differential ring gear to 90 to 110°C (194.0 to 230.0°F).

NOTICE:

Do not overheat the ring gear to 110°C (230.0°F) or more.

(b) Clean the contact surface of the front differential case.

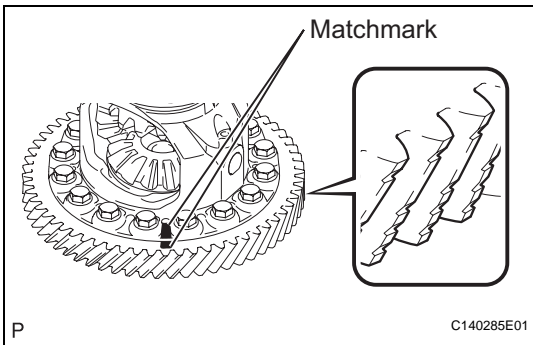

(c) Align the matchmarks, and install the front differential ring gear case quickly.

NOTICE:

- Check the position and number of the grooves on each end face of the differential ring gear.
- Do not install the bolts while the ring gear is hot.

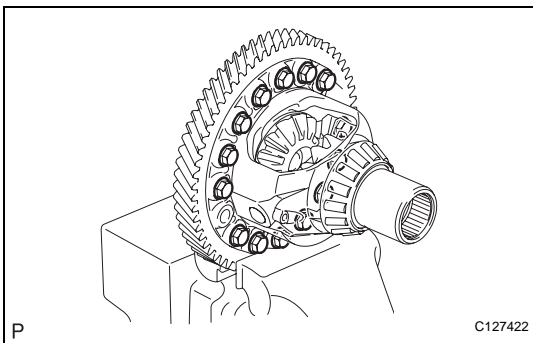

(d) Tighten the 14 bolts.

Torque: 95 N*m (969 kgf*cm, 70 ft.*lbf)

NOTICE:

Tighten the bolts a little at a time in diagonal order.

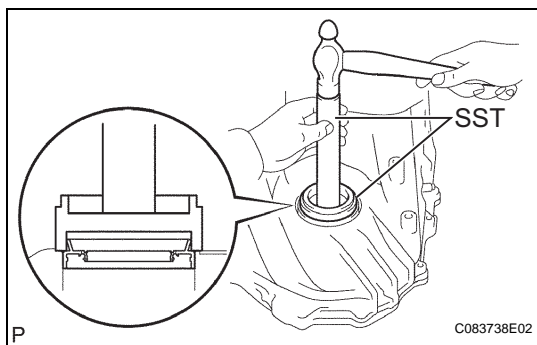

- 8. INSTALL DIFFERENTIAL SIDE BEARING RETAINER OIL SEAL**
- (a) Coat the lip of a new oil seal with a small amount of MP grease.
 - (b) Using SST and a hammer, tap in the oil seal.
SST 09223-15020, 09950-70010 (09951-07100)

AX

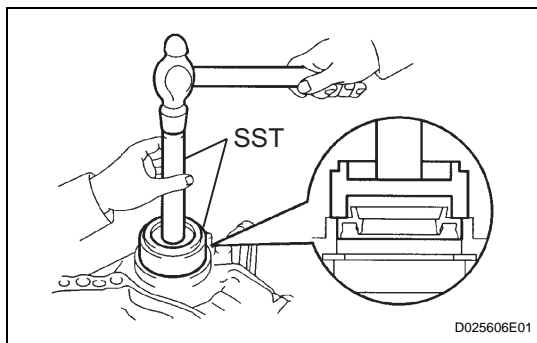

- 9. REMOVE TRANSAXLE HOUSING OIL SEAL**
- (a) Coat the lip of a new oil seal with a small amount of MP grease.
 - (b) Using SST and a hammer, tap in the oil seal.
SST 09710-30050, 09950-70010 (09951-07100)