

REASSEMBLY

1. INSTALL FRONT OIL PUMP OIL SEAL

- (a) Using SST and a hammer, tap in a new oil seal to the oil pump body.

SST 09350-32014 (09351-32140)

HINT:

The seal end should be flat with the outer edge of the oil pump.

- (b) Coat the lip of the oil seal with MP grease.

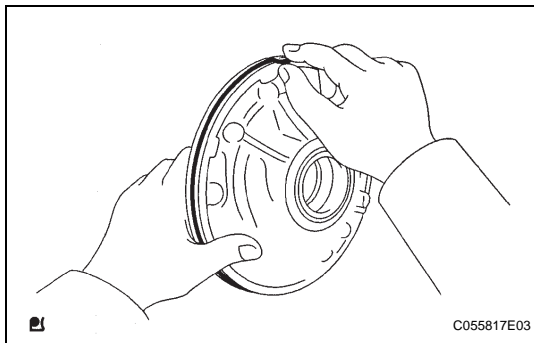
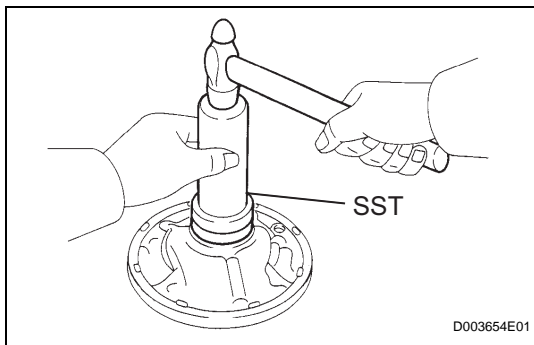

2. INSTALL FRONT OIL PUMP BODY O-RING

- (a) Coat a new O-ring with ATF, and install it to the oil pump body.

NOTICE:

- Make sure that the O-ring is not twisted or pinched.
- Apply enough ATF to the O-ring before installation.

3. INSTALL FRONT OIL PUMP DRIVEN GEAR

- (a) Coat the front oil pump driven gear with ATF, and install it to the oil pump body with the marked side facing upward.

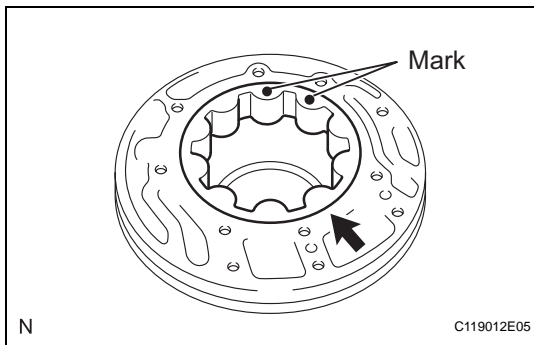

4. INSTALL FRONT OIL PUMP DRIVE GEAR

- (a) Coat the front oil pump drive gear with ATF, and install it to the oil pump body with the marked side facing upward.

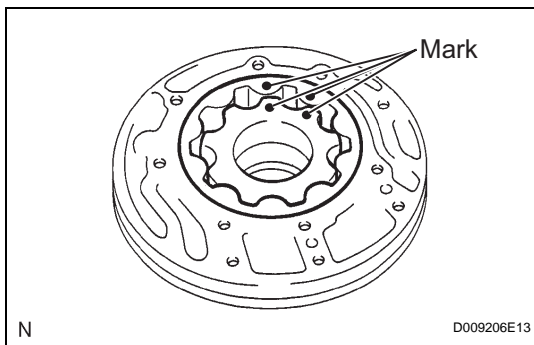

5. INSTALL STATOR SHAFT ASSEMBLY

- (a) Set the stator shaft and align it with each bolt hole.
 (b) Using a T30 "torx" socket, install the 11 bolts.

Torque: 9.8 N*m (100 kgf*cm, 87 in.*lbf)

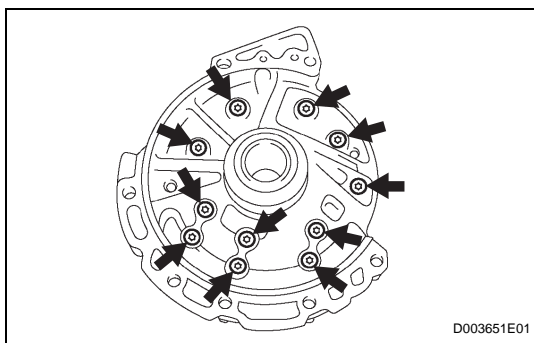

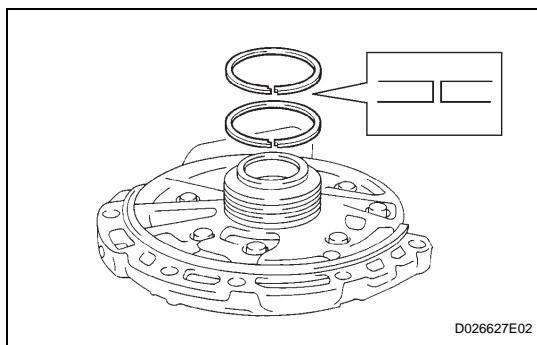
**6. INSTALL CLUTCH DRUM OIL SEAL RING**

- (a) Coat 2 new oil seal rings with ATF.
- (b) Install 2 new clutch drum oil seal rings.

NOTICE:

Do not expand the ring ends excessively.

7. INSPECT OIL PUMP ASSEMBLY (See page [AX-246](#))