

# AUTOMATIC TRANSAXLE ASSEMBLY

## COMPONENTS

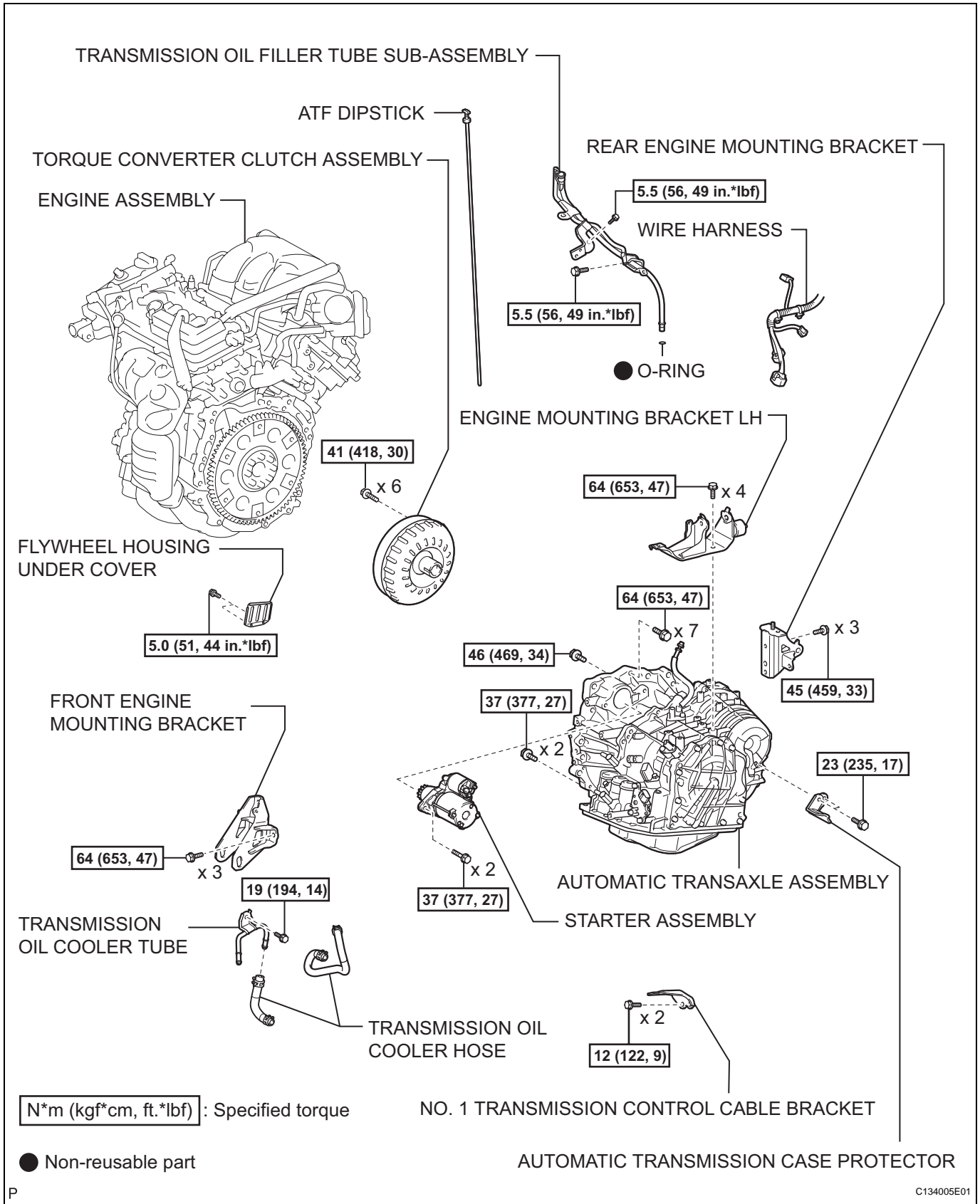

## REMOVAL

1. **REMOVE ENGINE ASSEMBLY WITH TRANSAXLE**
  - (a) Remove the engine with transaxle (see page [EM-21](#)).
2. **DRAIN AUTOMATIC TRANSAXLE FLUID**
  - (a) Remove the drain plug and gasket, and drain the ATF.
  - (b) Install a new gasket and the drain plug.  
**Torque: 47 N\*m (479 kgf\*cm, 35 ft.\*lbf)**
3. **REMOVE STARTER ASSEMBLY**
  - (a) Disconnect the starter connector.
  - (b) Open the terminal cap, and remove the nut and disconnect the starter wire.

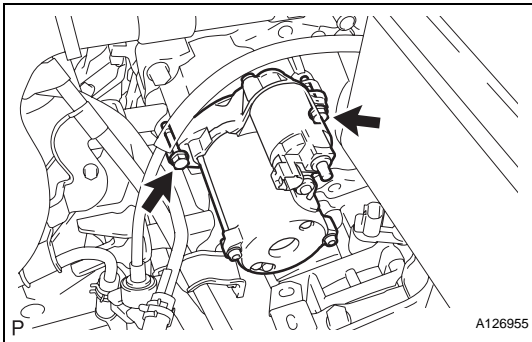
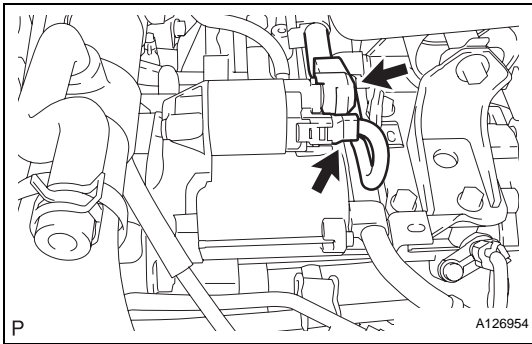

- (c) Remove the 2 bolts and starter.

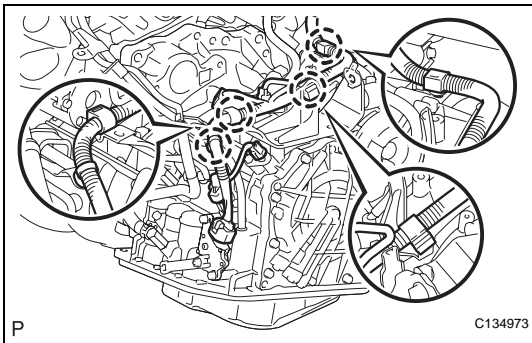

4. **DISCONNECT WIRE HARNESS**
  - (a) Disconnect the park/neutral position switch connector.
  - (b) Disconnect the transaxle wire connector.
  - (c) Disconnect the 2 speed sensor connectors.
  - (d) Disconnect the wire harness clamps.
5. **REMOVE TRANSMISSION OIL COOLER HOSE AND TUBE**
  - (a) Remove the oil cooler hoses and tube (see page [AX-151](#)).

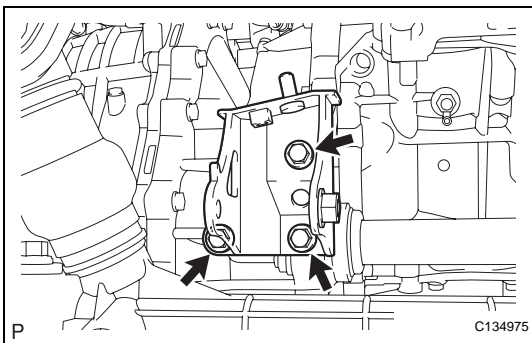

6. **REMOVE REAR ENGINE MOUNTING BRACKET**
  - (a) Remove the 3 bolts and mounting bracket.

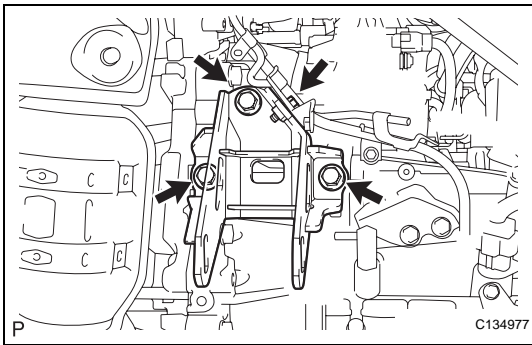

**7. REMOVE FRONT ENGINE MOUNTING BRACKET**

- (a) Remove the 4 bolts and mounting bracket.

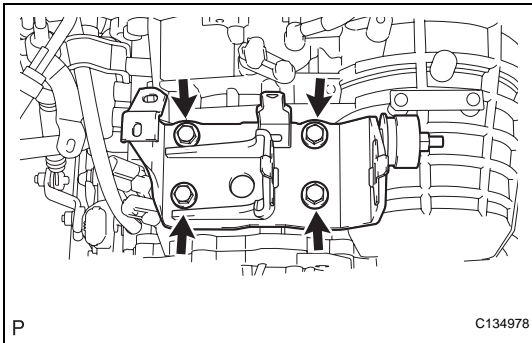

**8. REMOVE ENGINE MOUNTING BRACKET LH**

- (a) Remove the 4 bolts and mounting bracket.

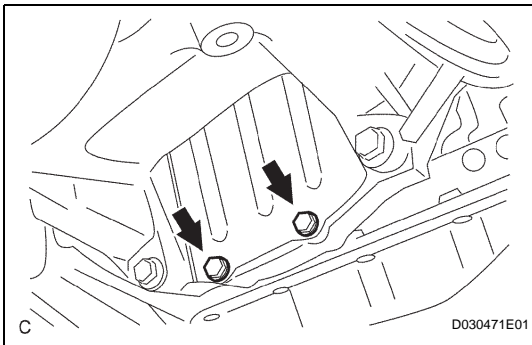

**9. REMOVE AUTOMATIC TRANSAXLE ASSEMBLY**

- (a) Remove the 2 bolts and flywheel housing under cover.

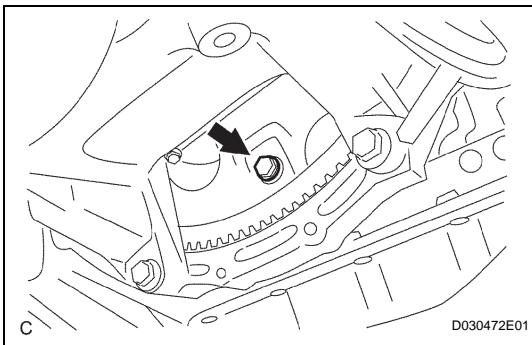

- (b) Turn the crankshaft to gain access and remove the 6 bolts while holding the crankshaft pulley bolt with a wrench.

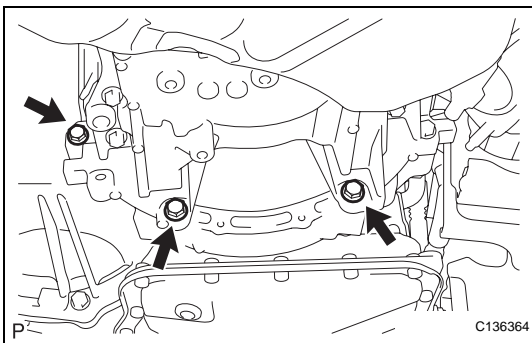

- (c) Remove the 3 lower side mounting bolts.

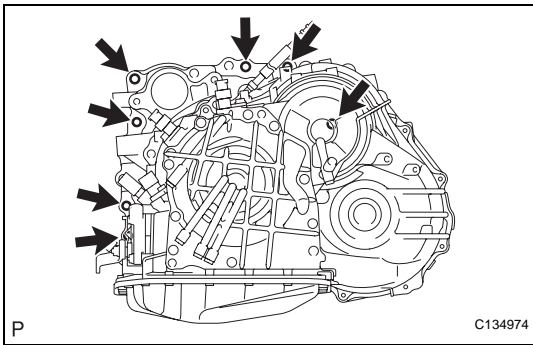

- (d) Remove the 7 upper side mounting bolts.
- (e) Separate and remove the automatic transaxle.

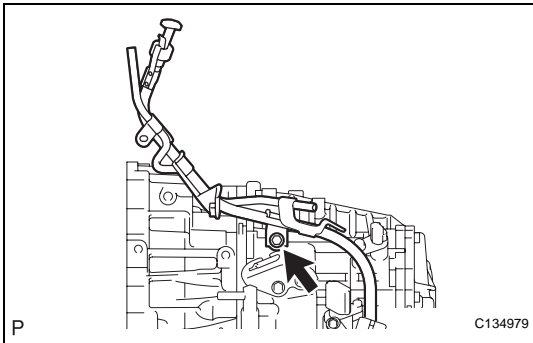

**10. REMOVE TRANSMISSION OIL FILLER TUBE SUB-ASSEMBLY**

- (a) Remove the ATF dipstick.
- (b) Remove the bolt and oil filler tube.

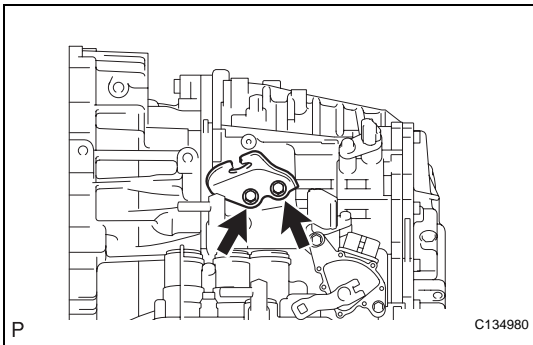

**11. REMOVE NO. 1 TRANSMISSION CONTROL CABLE BRACKET**

- (a) Remove the 2 bolts and cable bracket.

**12. REMOVE AUTOMATIC TRANSMISSION CASE PROTECTOR**

- (a) Remove the 2 bolts and protector.

**13. REMOVE TORQUE CONVERTER CLUTCH ASSEMBLY**