

REASSEMBLY

1. INSTALL MANUAL VALVE

- (a) Install the manual valve to the valve body.

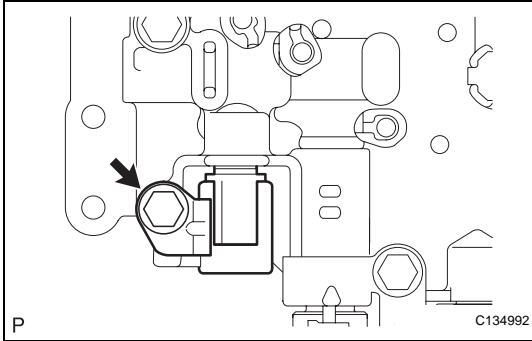

2. INSTALL SHIFT SOLENOID VALVE S4

- (a) Install the shift solenoid valve S4 to the valve body with the bolt.

Torque: 11 N*m (112 kgf*cm, 9 ft.*lbf)

3. INSTALL SHIFT SOLENOID VALVE SL2

- (a) Install the shift solenoid valve SL2 to the valve body with the bolt and plate.

Torque: 11 N*m (112 kgf*cm, 8 ft.*lbf)

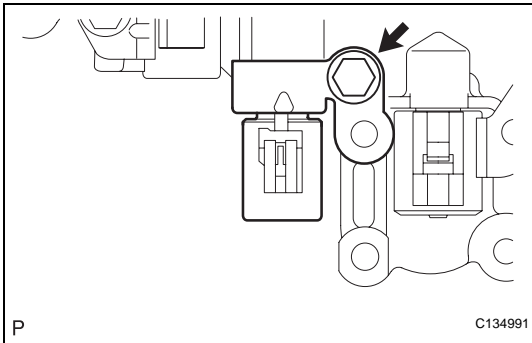

4. INSTALL SHIFT SOLENOID VALVE DSL

- (a) Install the shift solenoid valve DSL to the valve body with the bolt.

Torque: 11 N*m (112 kgf*cm, 8 ft.*lbf)

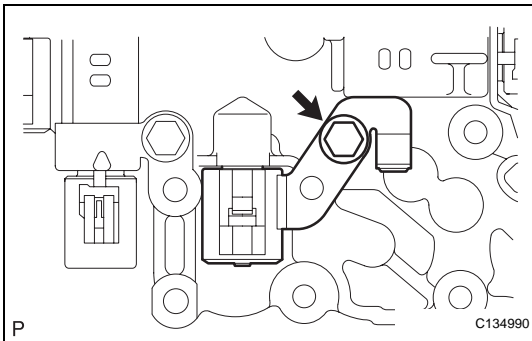

5. INSTALL SHIFT SOLENOID VALVE SL1

- (a) Install the shift solenoid valve SL1 to the valve body with the bolt and plate.

Torque: 6.6 N*m (67 kgf*cm, 58 in.*lbf)

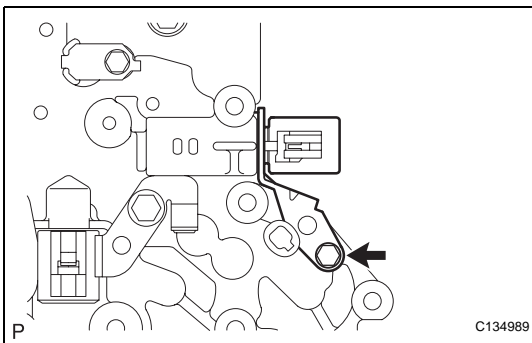

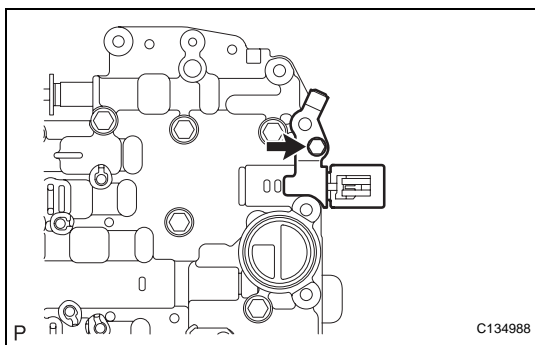
**6. INSTALL SHIFT SOLENOID VALVE SLT**

- (a) Install the shift solenoid valve SLT to the valve body with the bolt and plate.

Torque: 6.6 N*m (67 kgf*cm, 58 in.*lbf)