

## REPLACEMENT

### 1. REPLACE TRANSAXLE HOUSING OIL SEAL LH

- (a) Drain the automatic transaxle fluid.
  - (1) Remove the drain plug and gasket, and drain ATF.
  - (2) Install a new gasket and drain plug.  
**Torque: 47 N\*m (479 kgf\*cm, 35 ft.\*lbf)**
- (b) Remove the front drive shaft LH (see page [DS-41](#)).
- (c) Remove the transaxle housing oil seal LH.
  - (1) Using SST, tap out the oil seal.  
**SST 09308-0010**

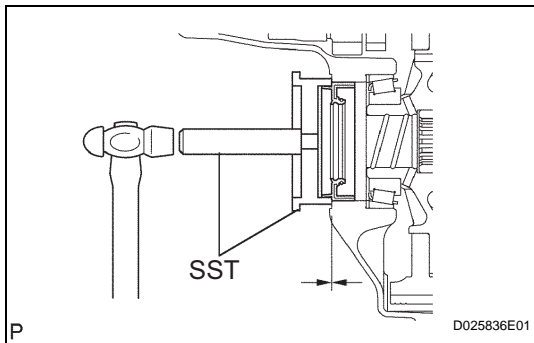
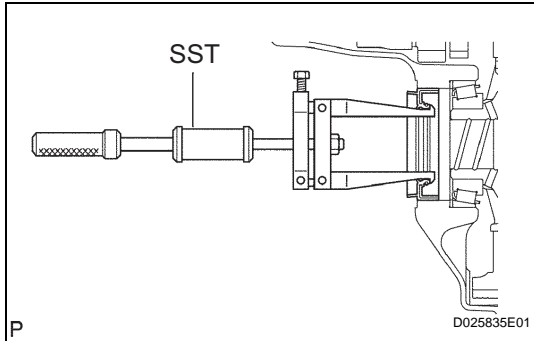

- (d) Install a new transaxle housing oil seal LH.
  - (1) Coat the lip of a new oil seal with MP grease.
  - (2) Using SST and a hammer, tap in the oil seal.  
**SST 09726-27012 (09726-02041), 09950-70010 (09951-07200, 09951-07200)**
- (e) Install the front drive shaft LH (see page [DS-65](#)).
- (f) Add automatic transaxle fluid.

**Standard depth:**

**0 +0.5 mm (0 +-0.020 in.)**

- (g) Inspect the transaxle fluid level (see page [AX-102](#)).

### 2. REPLACE TRANSAXLE HOUSING OIL SEAL RH

- (a) Remove the engine with transaxle (see page [EM-98](#)).
- (b) Drain the automatic transaxle fluid.
  - (1) Remove the drain plug and gasket, and drain ATF.
  - (2) Install a new gasket and the drain plug.  
**Torque: 47 N\*m (479 kgf\*cm, 35 ft.\*lbf)**
- (c) Remove the 3 bolts and drive shaft bearing bracket.
- (d) Remove the 3 bolts and engine mount bracket RR.
- (e) Remove the transfer assembly (see page [TF-59](#)).
- (f) Remove the transaxle housing oil seal RH.
  - (1) Using a screwdriver with vinyl tape wound around its tip, remove the oil seal.

**NOTICE:**

**Be careful not to damage the housing.**

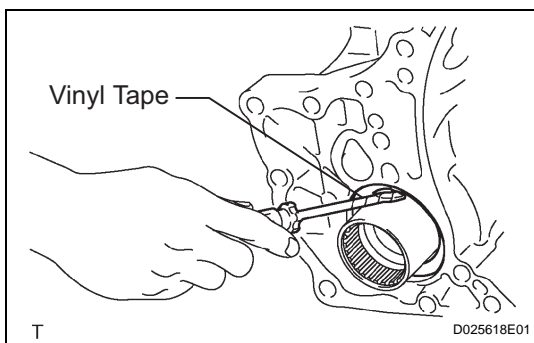

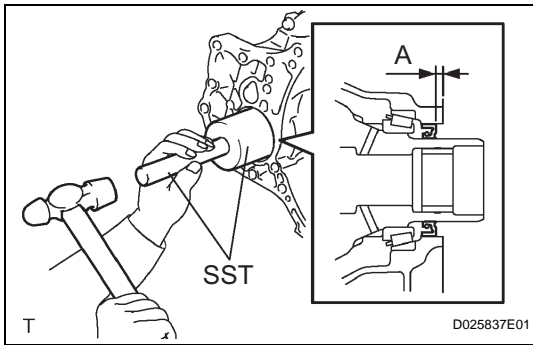

- (g) Install a new transaxle housing oil seal RH.
- (1) Coat the lip of a new oil seal with MP grease.
  - (2) Using SST and a hammer, tap in the oil seal.
- SST 09309-37010**  
**Standard depth:**  
**6.0 +-0.5 mm (0.236 +-0.020 in.)**
- (h) Install the transfer assembly (see page [TF-75](#)).
- (i) Install the engine mount bracket RR with the 3 bolts.  
**Torque: 64 N\*m (652 kgf\*cm, 47 ft.\*lbf)**
- (j) Install the drive shaft bearing bracket with the 3 bolts.  
**Torque: 64 N\*m (653 kgf\*cm, 47 ft.\*lbf)**
- (k) Install the engine with transaxle (see page [EM-105](#)).
- (l) Add automatic transaxle fluid.  
**Fluid type:**  
**Toyota Genuine ATF WS**
- (m) Inspect the fluid level (see page [AX-102](#)).