

DTC

B1781

Front Occupant Classification Sensor RH Circuit Malfunction**DESCRIPTION**

The front occupant classification sensor RH circuit consists of the occupant classification ECU and the front occupant classification sensor RH.

DTC B1781 is recorded when a malfunction is detected in the front occupant classification sensor RH circuit.

DTC No.	DTC Detection Condition	Trouble Area
B1781	When one of following conditions is met: <ul style="list-style-type: none"> Occupant classification ECU detects line short signal, open signal, short to ground signal or short to B+ signal in the front occupant classification sensor RH circuit for 2 seconds Front occupant classification sensor RH malfunction Occupant classification ECU malfunction 	<ul style="list-style-type: none"> Front seat wire RH Front seat RH (Front occupant classification sensor RH) Occupant classification ECU

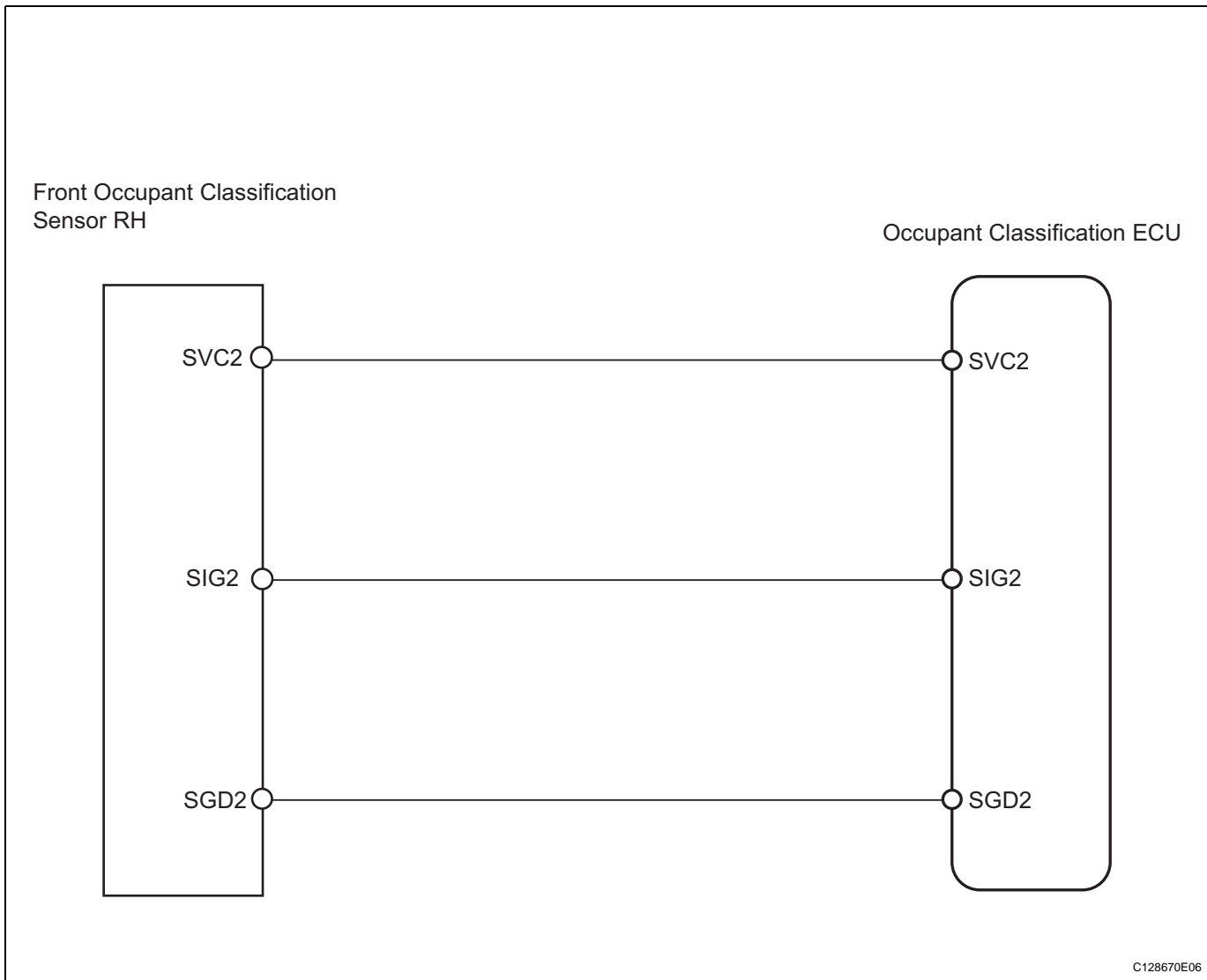
WIRING DIAGRAM

INSPECTION PROCEDURE

HINT:

- If troubleshooting (wire harness inspection) is difficult to perform, remove the front passenger seat installation bolts to see the undersurface of the seat cushion.
- In the above case, hold the seat so that it does not tip over. Holding the seat for a long period of time may cause a problem, such as seat rail deformation. Hold the seat up only for as long as necessary.

1**CHECK FOR DTC**

- Turn the ignition switch ON.
- Clear the DTCs (see page [RS-249](#)).

HINT:

First clear DTCs stored in the occupant classification ECU and then in the center airbag sensor.

- Turn the ignition switch OFF.
- Turn the ignition switch ON.
- Check the DTCs (see page [RS-249](#)).

OK:

DTC B1781 is not output.

HINT:

DTCs other than DTC B1781 may be output at this time, but they are not related to this check.

OK

USE SIMULATION METHOD TO CHECK

NG

2**CHECK CONNECTION OF CONNECTOR**

- Turn the ignition switch OFF.
- Disconnect the cable from the negative (-) battery terminal, and wait for at least 90 seconds.
- Check that the connectors are properly connected to the occupant classification ECU and the front occupant classification sensor RH.

OK:

The connectors are properly connected.

NG

CONNECT CONNECTOR

OK

RS

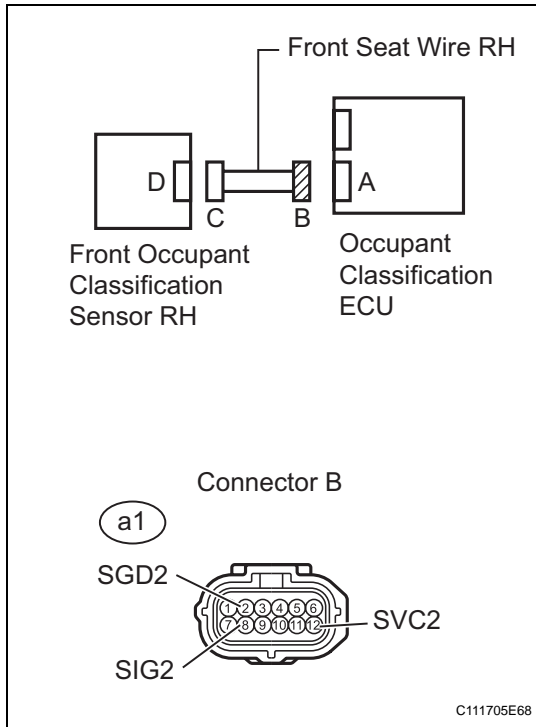
3 CHECK FRONT SEAT WIRE RH (TO B+)

- Disconnect the connectors from the occupant classification ECU and the front occupant classification sensor RH.
- Connect the cable to the negative (-) battery terminal, and wait for at least 2 seconds.
- Turn the ignition switch ON.
- Measure the voltage of the wire harness side connector.

Standard voltage

Tester Connection	Specified Condition
a1-2 (SGD2) - Body ground	Below 1 V
a1-8 (SIG2) - Body ground	Below 1 V
a1-12 (SVC2) - Body ground	Below 1 V

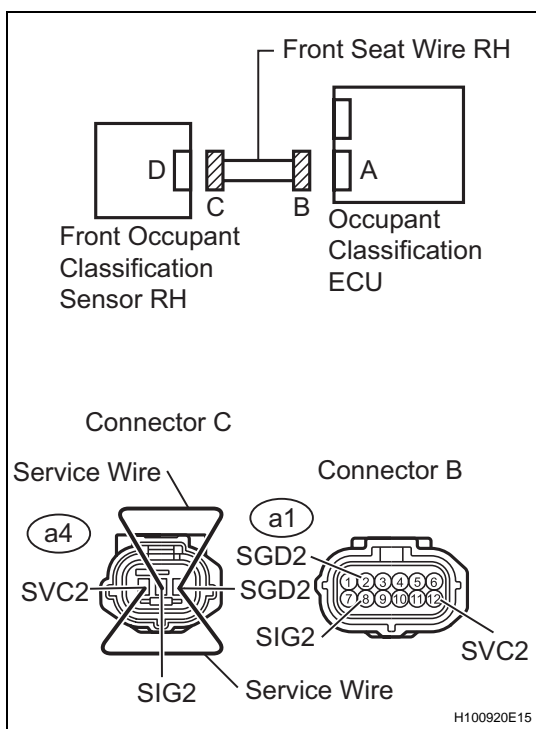
NG**REPAIR OR REPLACE FRONT SEAT WIRE RH****OK****4 CHECK FRONT SEAT WIRE RH (FOR OPEN)**

- Turn the ignition switch OFF.
- Disconnect the cable from the negative (-) battery terminal, and wait for at least 90 seconds.
- Using a service wire, connect terminals a4-1 (SVC2) and a4-3 (SGD2), and connect terminals a4-2 (SIG2) and a4-3 (SGD2) of connector C.

NOTICE:**Do not forcibly insert a service wire into the terminals of the connector when connecting them.**

- Measure the resistance of the wire harness side connector.

Standard resistance

Tester Connection	Specified Condition
a1-8 (SIG2) - a1-2 (SGD2)	Below 1 Ω
a1-12 (SVC2) - a1-2 (SGD2)	Below 1 Ω

NG**REPAIR OR REPLACE FRONT SEAT WIRE RH****OK**

5 CHECK FRONT SEAT WIRE RH (FOR SHORT)

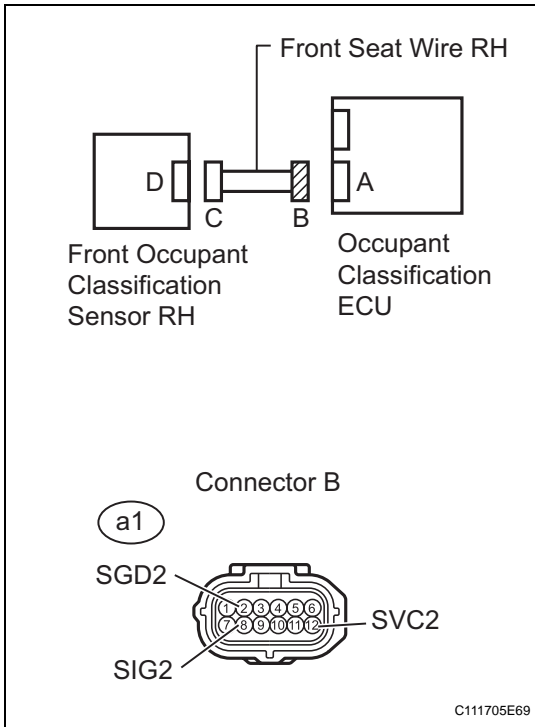

- (a) Disconnect the service wire from connector C.
- (b) Measure the resistance of the wire harness side connector.

Standard resistance

Tester Connection	Specified Condition
a1-8 (SIG2) - a1-2 (SGD2)	1 MΩ or higher
a1-12 (SVC2) - a1-2 (SGD2)	1 MΩ or higher
a1-8 (SIG2) - a1-12 (SVC2)	1 MΩ or higher

NG REPAIR OR REPLACE FRONT SEAT WIRE RH

OK

6 CHECK FRONT SEAT WIRE RH (TO GROUND)

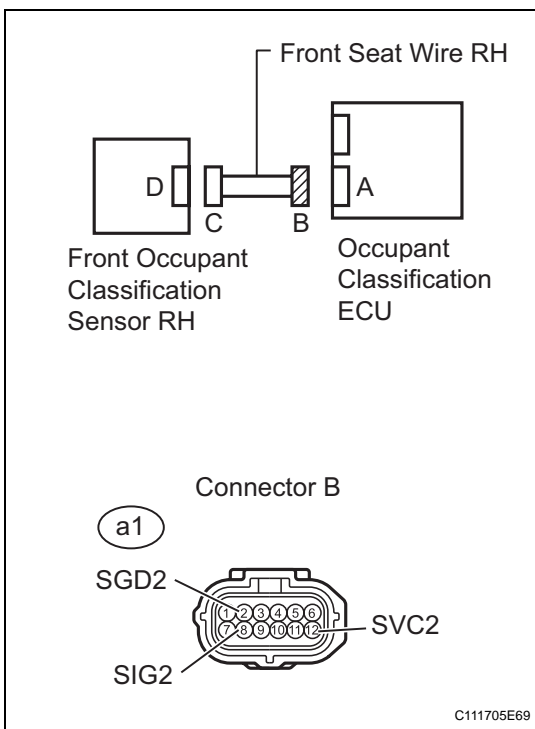

- (a) Measure the resistance of the wire harness side connector.

Standard resistance

Tester Connection	Specified Condition
a1-2 (SGD2) - Body ground	1 MΩ or higher
a1-8 (SIG2) - Body ground	1 MΩ or higher
a1-12 (SVC2) - Body ground	1 MΩ or higher

NG REPAIR OR REPLACE FRONT SEAT WIRE RH

OK

7 CHECK FOR DTC

- (a) Connect the connectors to the occupant classification ECU and the front occupant classification sensor RH.
- (b) Connect the cable to the negative (-) battery terminal, and wait for at least 2 seconds.
- (c) Turn the ignition switch ON.
- (d) Clear the DTCs (see page [RS-249](#)).

HINT:

First clear DTCs stored in the occupant classification ECU and then in the center airbag sensor.

- (e) Turn the ignition switch OFF.
- (f) Turn the ignition switch ON.
- (g) Check the DTCs (see page [RS-249](#)).

OK:

DTC B1781 is not output.

HINT:

DTCs other than DTC B1781 may be output at this time, but they are not related to this check.

OK**USE SIMULATION METHOD TO CHECK****NG****8 REPLACE OCCUPANT CLASSIFICATION ECU**

- (a) Turn the ignition switch OFF.
- (b) Disconnect the cable from the negative (-) battery terminal, and wait for at least 90 seconds.
- (c) Replace the occupant classification ECU (see page [RS-392](#)).

HINT:

Perform the inspection using parts from a normal vehicle if possible.

NEXT**9 PERFORM ZERO POINT CALIBRATION**

- (a) Connect the cable to the negative (-) battery terminal, and wait for at least 2 seconds.
- (b) Connect the intelligent tester to the DLC3.
- (c) Turn the ignition switch ON.
- (d) Using the intelligent tester, perform the zero point calibration (see page [RS-241](#)).

OK:

COMPLETED is displayed.

NG**Go to step 12****OK**

10 PERFORM SENSITIVITY CHECK

- (a) Using the intelligent tester, perform the sensitivity check (see page [RS-241](#)).

Standard value:

27 to 33 kg (59.52 to 72.75 lb)

NG

Go to step 12

OK

11 CHECK FOR DTC

- (a) Connect the cable to the negative (-) battery terminal, and wait for at least 2 seconds.
 (b) Turn the ignition switch ON.
 (c) Clear the DTCs (see page [RS-249](#)).

HINT:

First clear DTCs stored in the occupant classification ECU and then in the center airbag sensor assembly.

- (d) Turn the ignition switch OFF.
 (e) Turn the ignition switch ON.
 (f) Check the DTCs (see page [RS-249](#)).

OK:

DTC B1781 is not output.

HINT:

DTCs other than DTC B1781 may be output at this time, but they are not related to this check.

OK

END

NG

RS

12 REPLACE FRONT SEAT ASSEMBLY RH

- (a) Turn the ignition switch OFF.
 (b) Disconnect the cable from the negative (-) battery terminal, and wait for at least 90 seconds.
 (c) Replace the front seat RH (see page [SE-8](#)).

NEXT

13 PERFORM ZERO POINT CALIBRATION

- (a) Connect the cable to the negative (-) battery terminal, and wait for at least 2 seconds.
 (b) Connect the intelligent tester to the DLC3.
 (c) Turn the ignition switch ON.
 (d) Using the intelligent tester, perform the zero point calibration (see page [RS-241](#)).

OK:

COMPLETED is displayed.

NEXT

14 | **PERFORM SENSITIVITY CHECK**

- (a) Using the intelligent tester, perform the sensitivity check (see page [RS-241](#)).

Standard value:

27 to 33 kg (59.52 to 72.75 lb)

NEXT

END