

POWER SEAT SWITCH

INSPECTION

1. INSPECT FRONT POWER SEAT SWITCH

- (a) Measure the resistance between the terminals when each switch is operated.

Standard resistance

Slide switch

Tester Connection	Switch Condition	Specified Condition
1 (B) - 9 (SLDF)	FRONT	Below 1 Ω
4 (E) - 6 (SLDR)	FRONT	Below 1 Ω
4 (E) - 6 (SLDR)	OFF	Below 1 Ω
4 (E) - 9 (SLDF)	OFF	Below 1 Ω
1 (B) - 6 (SLDR)	REAR	Below 1 Ω
4 (E) - 9 (SLDF)	REAR	Below 1 Ω

Front vertical switch

Tester Connection	Switch Condition	Specified Condition
1 (B) - 10 (FUP)	UP	Below 1 Ω
4 (E) - 5 (FDWN)	UP	Below 1 Ω
4 (E) - 5 (FDWN)	OFF	Below 1 Ω
4 (E) - 10 (FUP)	OFF	Below 1 Ω
1 (B) - 5 (FDWN)	DOWN	Below 1 Ω
4 (E) - 10 (FUP)	DOWN	Below 1 Ω

Lifter switch

Tester Connection	Switch Condition	Specified Condition
1 (B) - 7 (RUP)	UP	Below 1 Ω
4 (E) - 8 (RDWN)	UP	Below 1 Ω
4 (E) - 7 (RUP)	OFF	Below 1 Ω
4 (E) - 8 (RDWN)	OFF	Below 1 Ω
1 (B) - 8 (RDWN)	DOWN	Below 1 Ω
4 (E) - 7 (RUP)	DOWN	Below 1 Ω

Reclining switch

Tester Connection	Switch Condition	Specified Condition
1 (B) - 3 (RCLF)	FRONT	Below 1 Ω
2 (RCLR) - 4 (E)	FRONT	Below 1 Ω
2 (RCLR) - 4 (E)	OFF	Below 1 Ω
3 (RCLF) - 4 (E)	OFF	Below 1 Ω
1 (B) - 2 (RCLR)	REAR	Below 1 Ω
3 (RCLF) - 4 (E)	REAR	Below 1 Ω

If the result is not as specified, replace the switch.

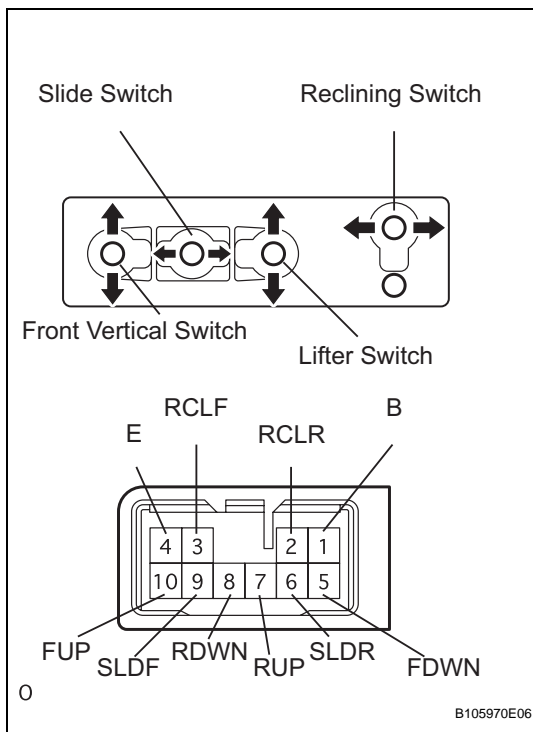

B105970E06