

# COMPONENTS

(2006/01- )

for 2AZ-FE

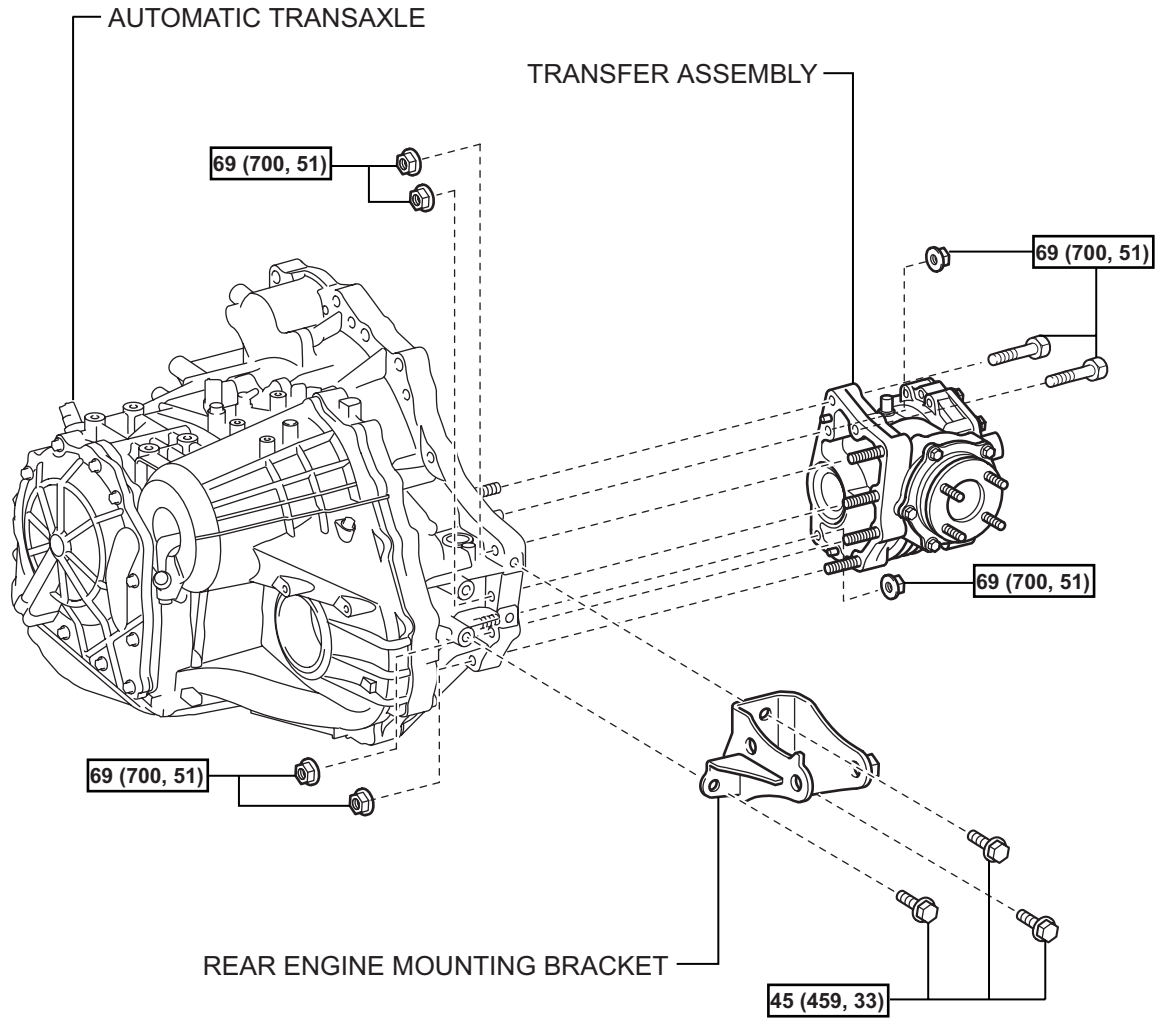

**N\*m (kgf\*cm, ft.\*lbf)** : Specified torque

TF

for 2GR-FE

TF

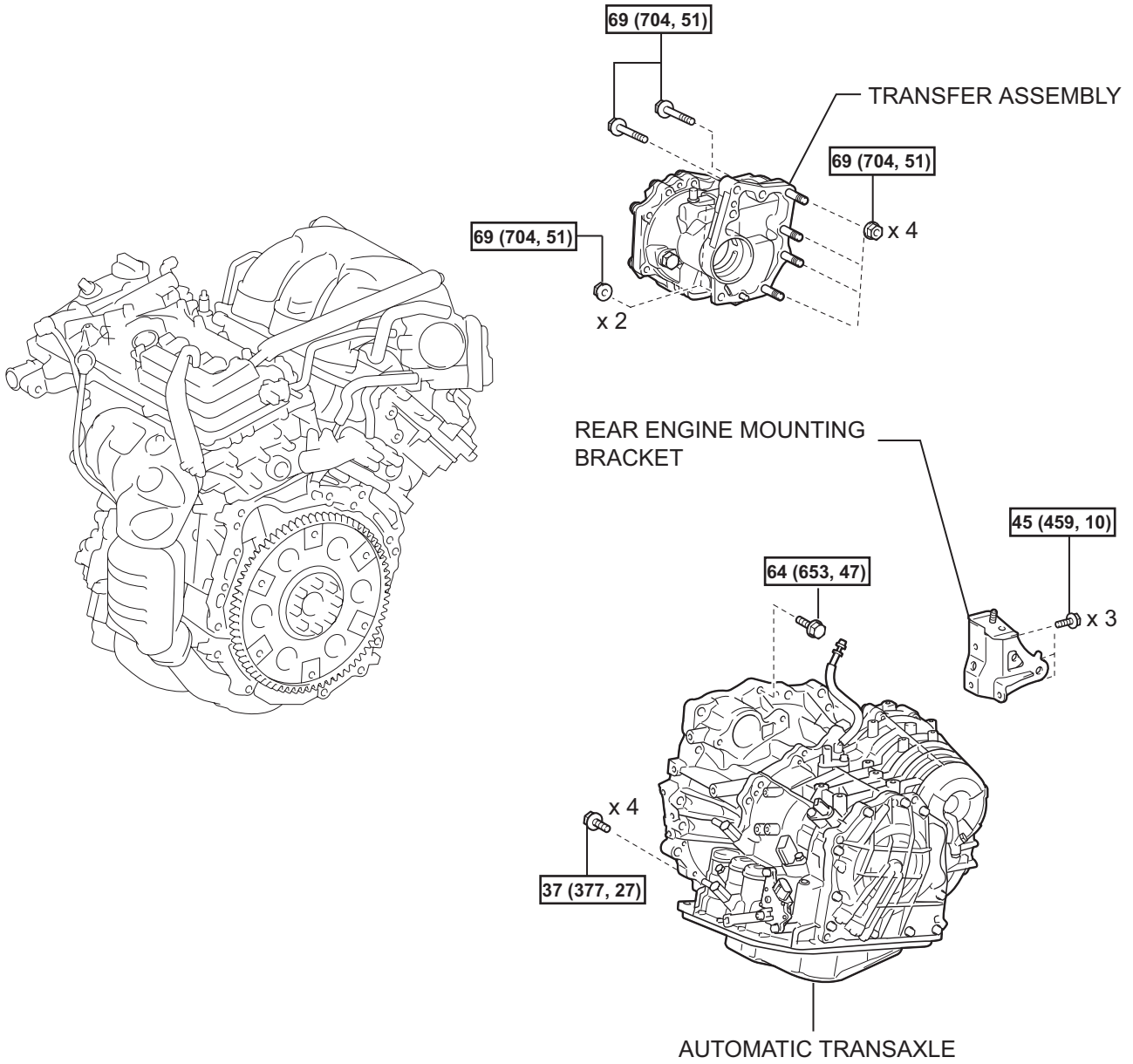

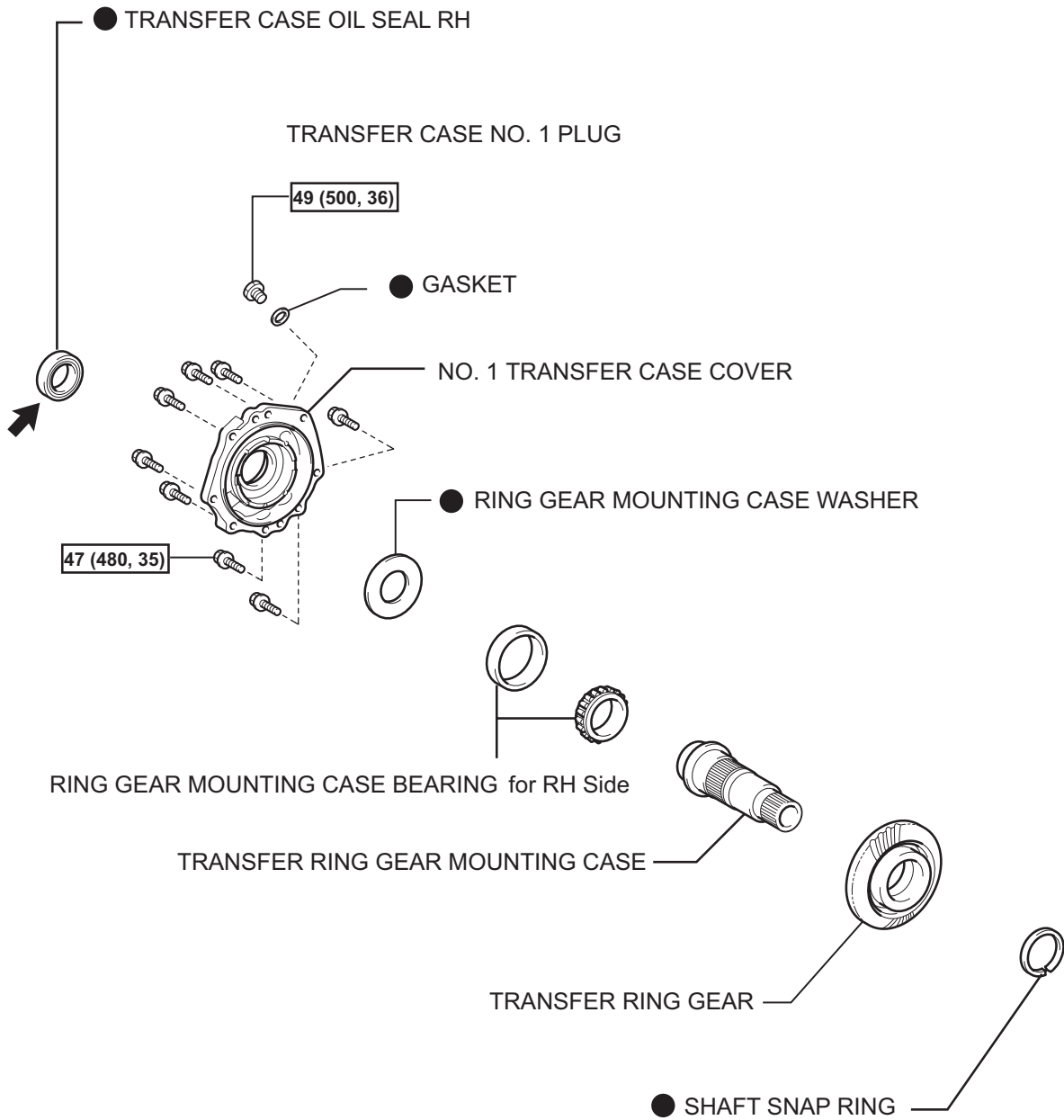

$\boxed{\text{N*m (kgf*cm, ft.*lbf)}}$  : Specified torque

● Non-reusable part

← Apply MP grease

TF

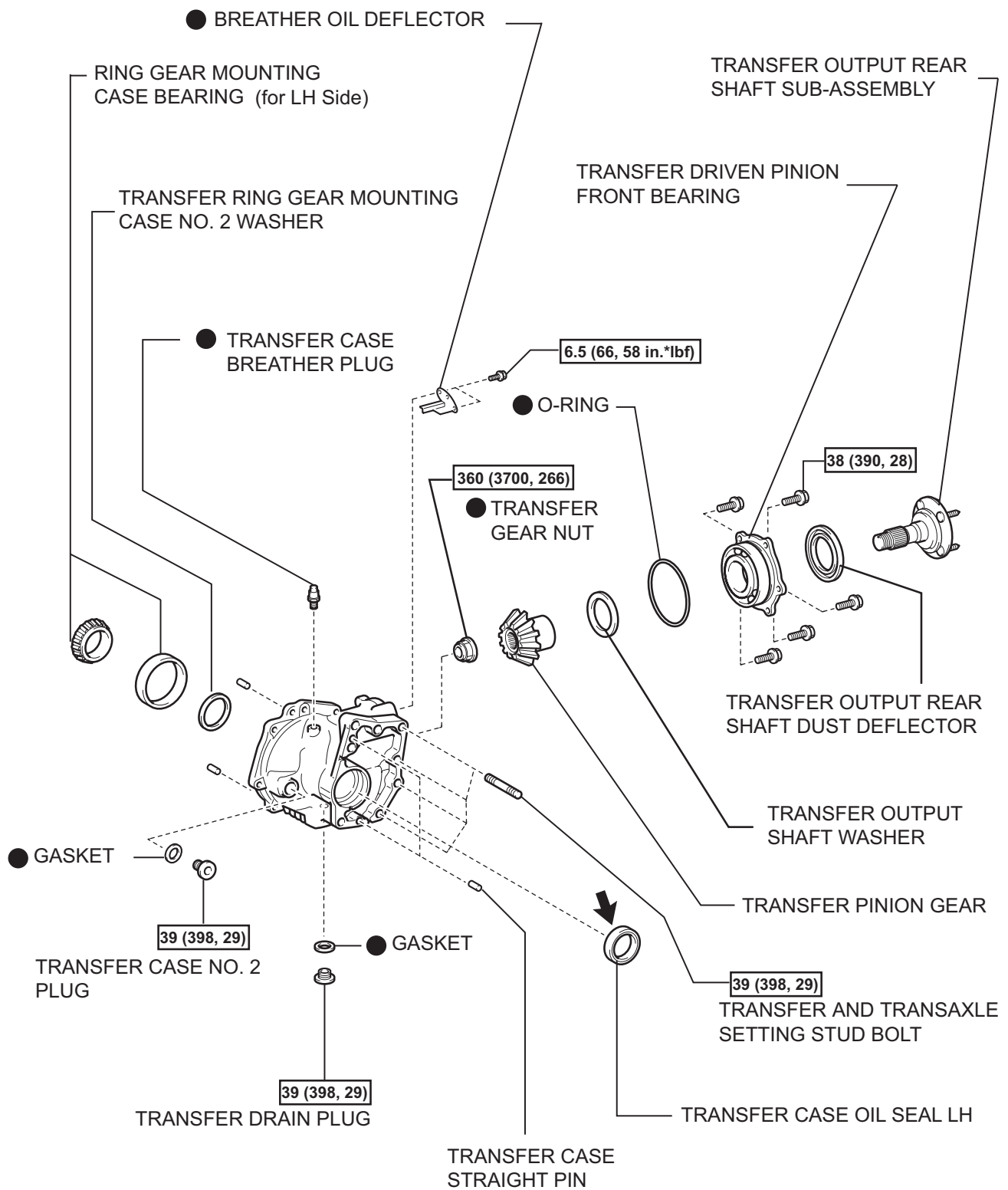

$N \cdot m$  (kgf $\cdot$ cm, ft. $\cdot$ lbf) : Specified torque

● Non-reusable part

← MP grease