

## ON-VEHICLE INSPECTION

### 1. CHECK BRAKE FLUID LEVEL WARNING SWITCH

- (a) Remove the reservoir filler cap and strainer.
- (b) Disconnect the brake fluid level warning switch connector.

- (c) Measure the resistance of the switch.

#### HINT:

There is a float inside the reservoir. Its position can be changed by increasing or decreasing the brake fluid level.

#### Standard resistance

Tester Connection	Condition	Specified Condition
1 - 2	Float up (Switch OFF)	10 k $\Omega$ or higher
1 - 2	Float down (Switch ON)	Below 1 $\Omega$

If the value is not as specified, replace the brake master cylinder reservoir sub-assembly.

- (d) Add brake fluid to the MAX level.

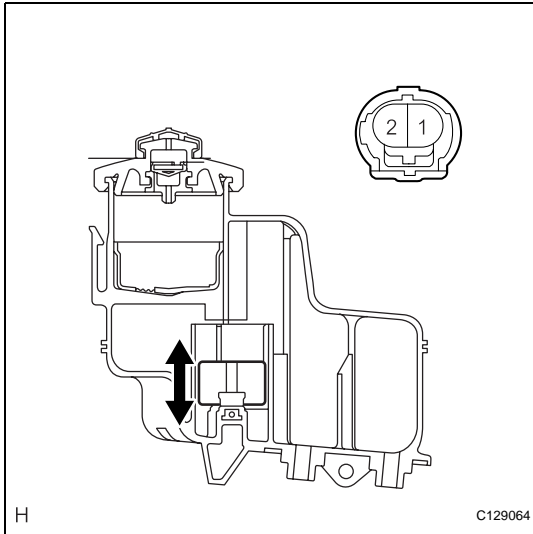

## REMOVAL

(2005/11-2006/01)

### NOTICE:

- The master cylinder and piston are designed so that the piston can easily fall out. Prevent this by making sure that the tip of the master cylinder points downward when handling the master cylinder.
- Make sure foreign matter does not attach to the master cylinder's piston. If foreign matter attaches, clean it off with a cloth. Then apply lithium soap base glycol grease to the entire outer circumference contact surface area of the piston.

### 1. REMOVE AIR CLEANER CASE SUB-ASSEMBLY

- (a) Remove the air cleaner case (see page [EM-98](#)).

#### HINT:

Refer to the procedures from the removal of the purge VSV up until the removal of the air cleaner case.

### 2. DRAIN BRAKE FLUID

#### NOTICE:

Wash off brake fluid immediately if it comes in contact with any painted surface.

### 3. REMOVE BRAKE MASTER CYLINDER SUB-ASSEMBLY

- (a) Release the vacuum pressure in the brake booster as follows.

- (1) Stop the engine.
- (2) Depress the brake pedal several times.

- (b) Disconnect the brake fluid level warning switch connector labeled A.

- (c) Using SST, disconnect the 2 brake lines labeled B from the master cylinder.

**SST 09023-00101**

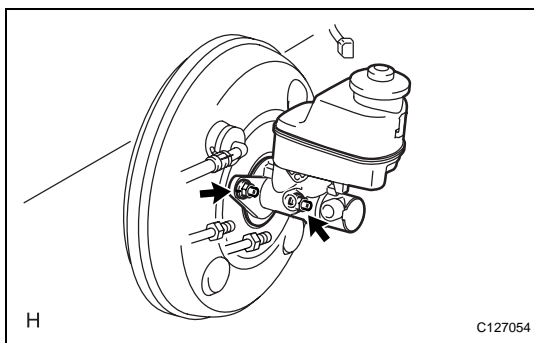
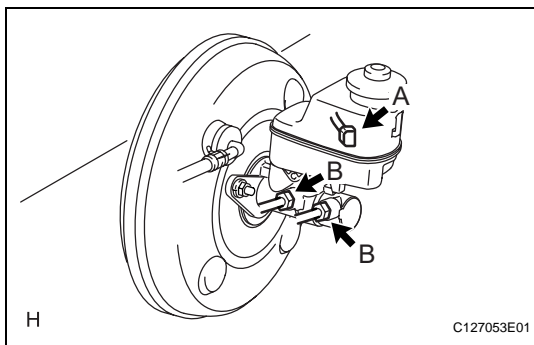

- (d) Remove the 2 nuts.

- (e) Pull out the master cylinder from the brake booster.

#### NOTICE:

- The master cylinder and piston are designed so that the piston can easily fall out. Prevent this by making sure that the tip of the master cylinder points downward when handling the master cylinder.

- **Make sure foreign matter does not attach to the master cylinder's piston. If foreign matter attaches, clean it off with a cloth. Then apply lithium soap base glycol grease to the entire outer circumference contact surface area of the piston.**
- (f) Remove the O-ring from the master cylinder.