

CONDENSER COMPONENTS

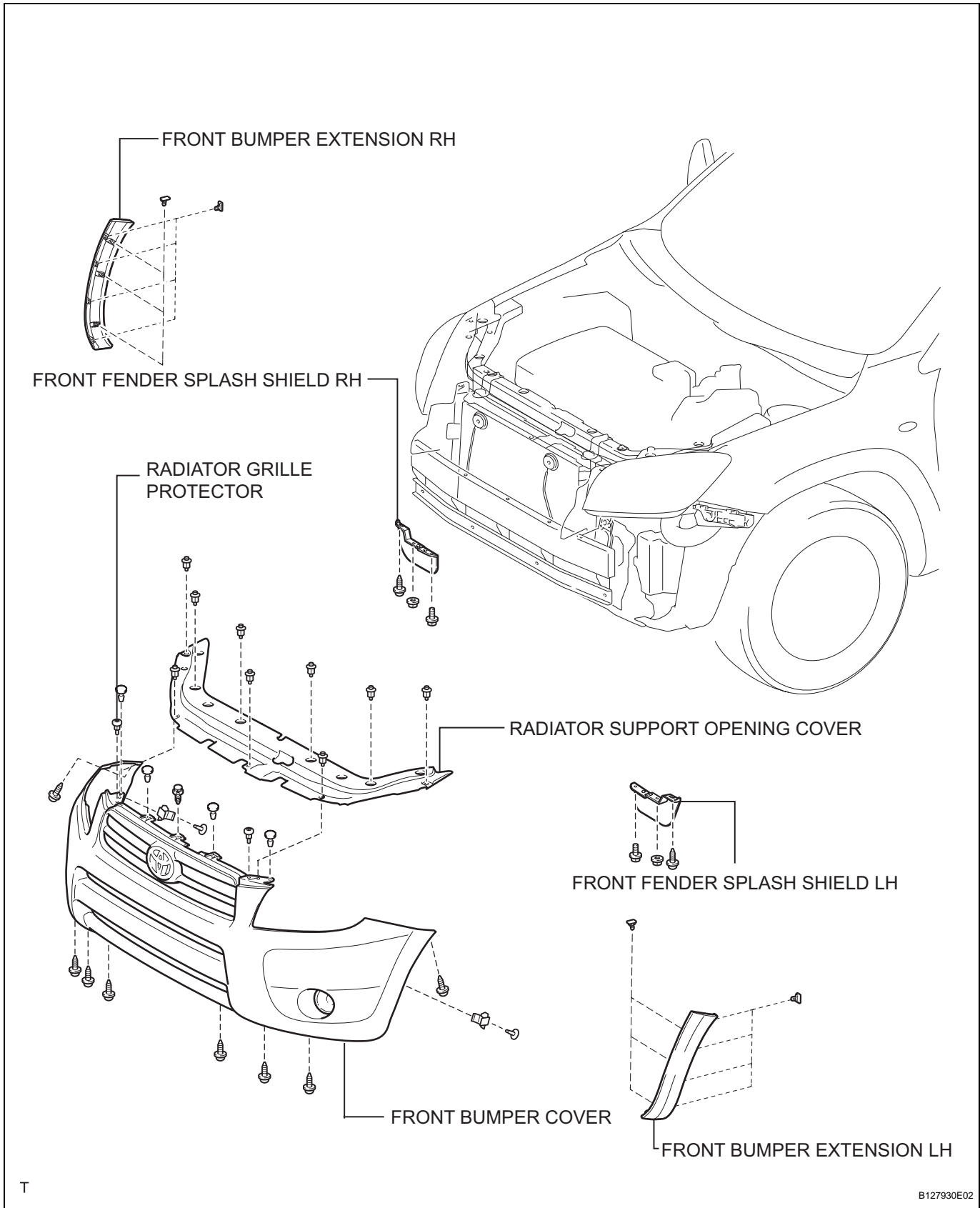

AC

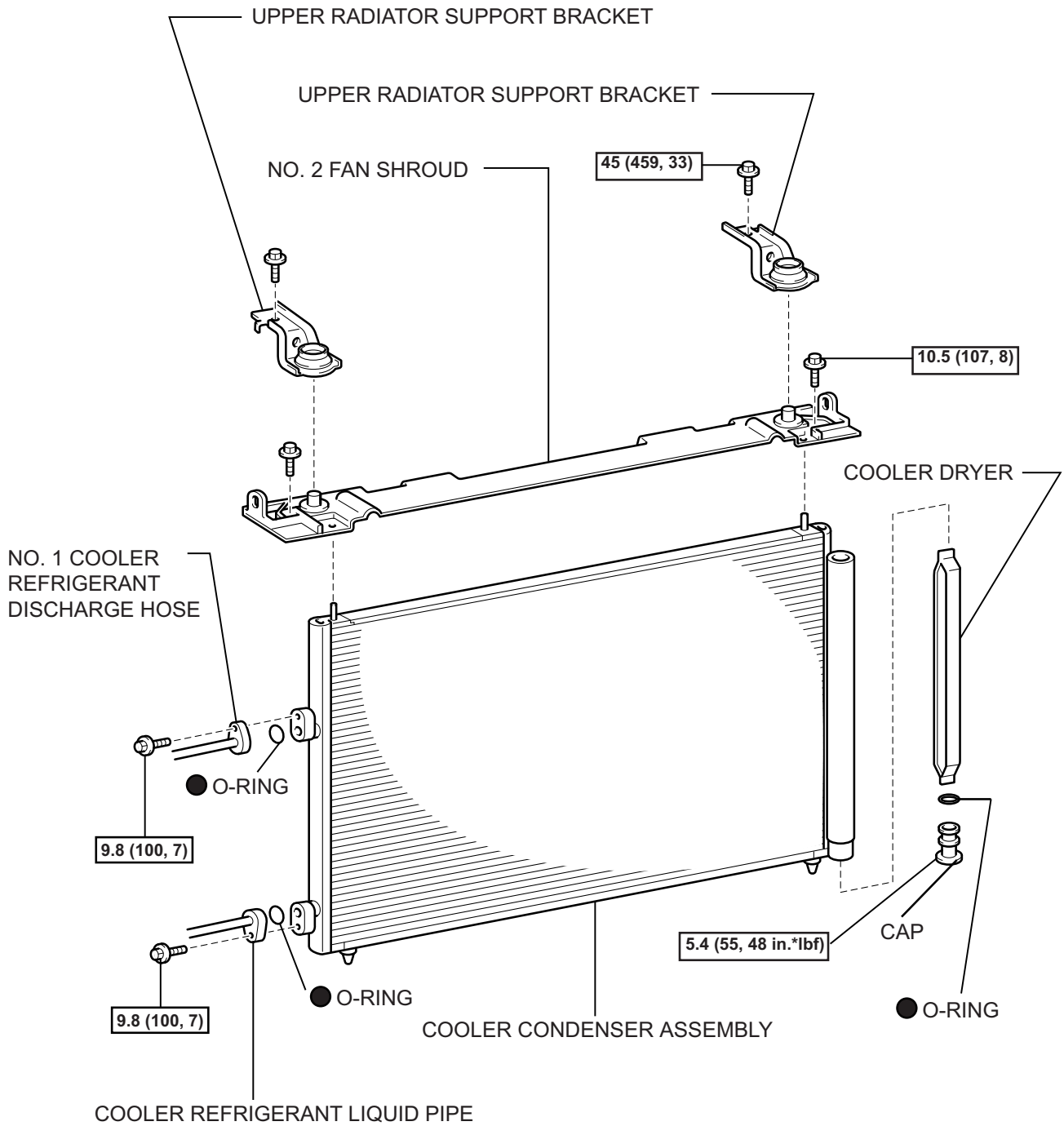

N*m (kgf*cm, ft.*lbf) : Specified torque

● Non-reusable part

← Compressor oil ND-OIL 8 or equivalent