

**MIL Circuit**

**DESCRIPTION**

The MIL (Malfunction Indicator Lamp) is used to indicate vehicle malfunction detections by the ECM. When the ignition switch is turned ON, power is supplied to the MIL circuit, and the ECM provides the circuit ground which illuminates the MIL.

The MIL operation can be checked visually: When the ignition switch is first turned ON, the MIL should be illuminated and should then turn off. If the MIL remains illuminated or is not illuminated, conduct the following troubleshooting procedure using the intelligent tester.

**WIRING DIAGRAM**

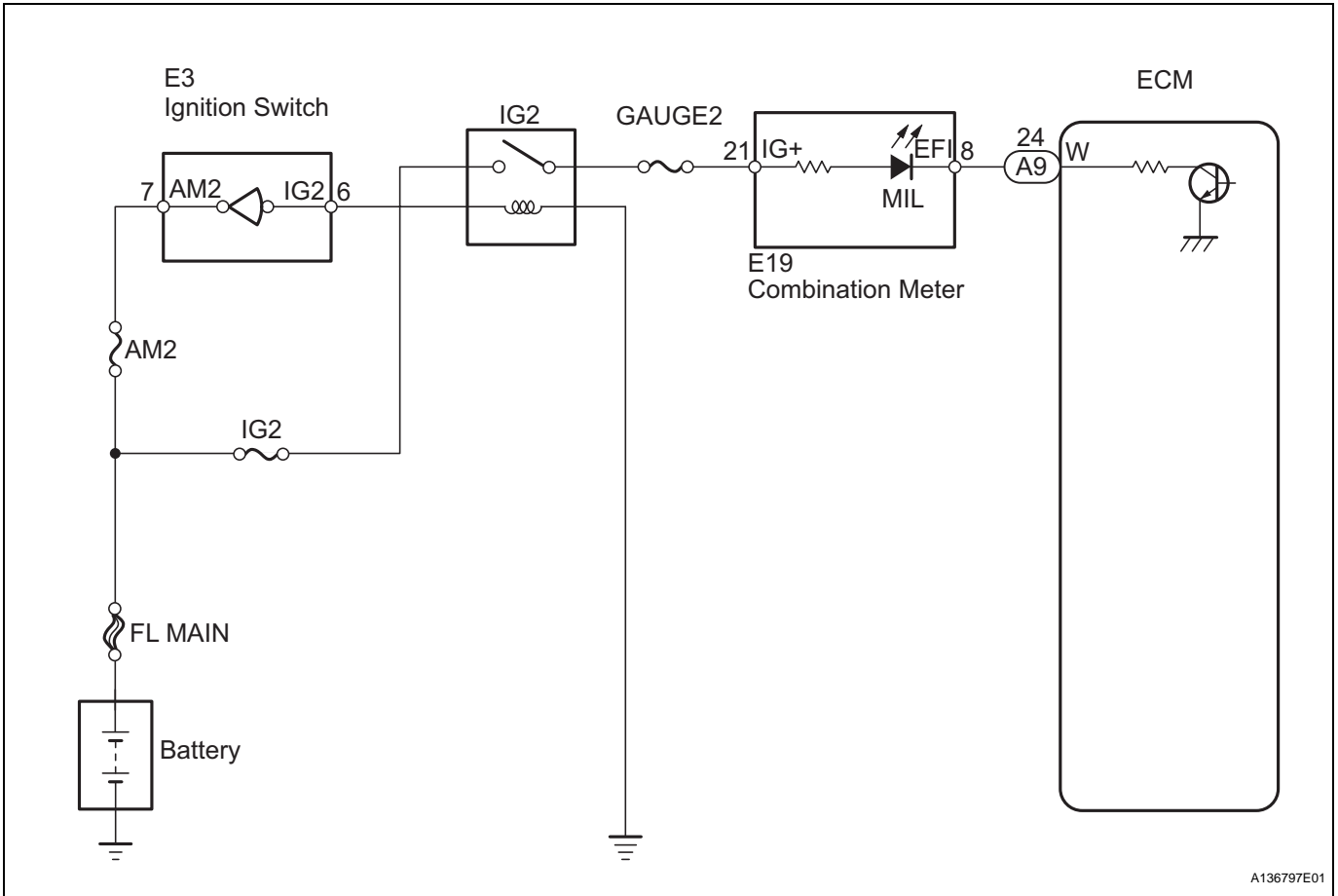

**ES**

**INSPECTION PROCEDURE**

**1 CHECK THAT MIL IS ILLUMINATED**

- (a) Perform troubleshooting in accordance with the table below.

Condition	Proceed to
MIL remains ON	A
MIL does not illuminate	B

**B** Go to step 5

A136797E01

A

**2 CHECK WHETHER MIL TURNS OFF**

- (a) Connect the intelligent tester to the DLC3.
- (b) Turn the ignition switch ON and turn the tester ON.
- (c) Select the following menu items: DIAGNOSIS / ENHANCED OBD II / DTC INFO / CURRENT CODES.
- (d) Check if any DTCs have been stored. Note down any DTCs.
- (e) Clear DTCs (see page [ES-39](#)).
- (f) Check if the MIL goes off.

**Standard:****MIL should go off.**

OK

**REPAIR CIRCUITS INDICATED BY OUTPUT DTCs**

NG

**3 CHECK WIRE HARNESS (CHECK FOR SHORT IN WIRE HARNESS)**

Wire Harness Side:

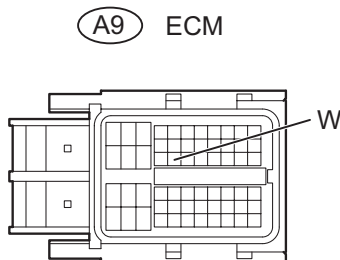

A115671E40

- (a) Disconnect the A9 ECM connector.
- (b) Turn the ignition switch ON.
- (c) Check that the MIL is not illuminated.

**OK:****MIL is not illuminated.**

- (d) Reconnect the ECM connector.

OK

**REPLACE ECM**

NG

**4 CHECK WIRE HARNESS (COMBINATION METER - ECM)**

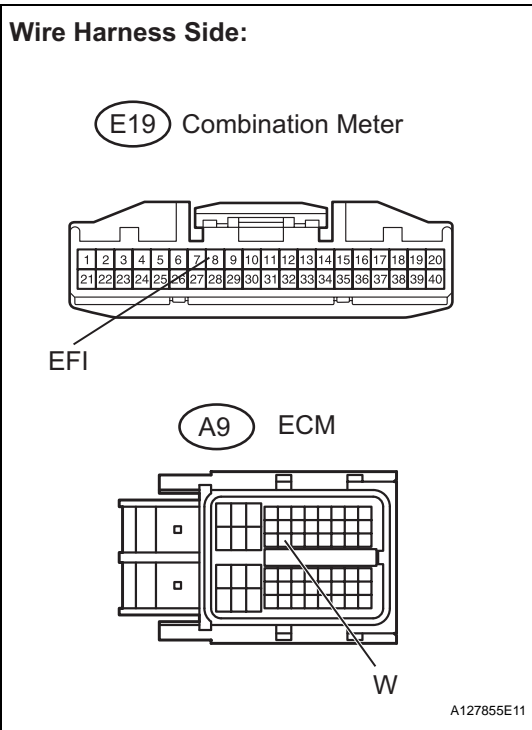

- (a) Disconnect the A9 ECM connector.
  - (b) Disconnect the E19 combination meter connector.
  - (c) Measure the resistance.
- Standard resistance**

Tester Connection	Specified Condition
A9-24 (W) or E19-8 (EFI) - Body ground	10 kΩ or higher

- (d) Reconnect the ECM connector.
- (e) Reconnect the combination meter connector.

**OK** → **REPAIR OR REPLACE COMBINATION METER ASSEMBLY**

**ES**

**NG**

**REPAIR OR REPLACE HARNESS AND CONNECTOR**

**5 CHECK THAT MIL IS ILLUMINATED**

- (a) Check if the MIL is illuminated when the ignition switch is turned ON.
- OK:**  
MIL should be illuminated.

**OK** → **SYSTEM OK**

**NG**

**6 CHECK THAT ENGINE STARTS**

- (a) Turn the ignition switch ON.
- (b) Start the engine.

Result	Proceed to
Engine starts	A
Engine does not start*	B

**HINT:**

\*: The intelligent tester cannot communicate with the ECM.

B

GO TO VC OUTPUT CIRCUIT

A

7

INSPECT COMBINATION METER ASSEMBLY (MIL CIRCUIT)

(a) Check the MIL circuit (see page [ME-17](#)).

NG

REPAIR OR REPLACE COMBINATION  
METER ASSEMBLY

OK

ES

CHECK AND REPLACE HARNESS AND CONNECTOR (COMBINATION METER - ECM)