

DTC	P2118	Throttle Actuator Control Motor Current Range / Performance
------------	--------------	--

DESCRIPTION

The ETCS (Electronic Throttle Control System) has a dedicated power supply circuit. The voltage (+BM) is monitored and when it is low (less than 4 V), the ECM determines that there is a malfunction in the ETCS and cuts off the current to the throttle actuator.

When the voltage becomes unstable, the ETCS itself becomes unstable. For this reason, when the voltage is low, the current to the throttle actuator is cut. If repairs are made and the system returns to normal, turn the ignition switch OFF. The ECM then allows the current to flow to the throttle actuator so that it can be restarted.

HINT:

The ETCS does not use a throttle cable.

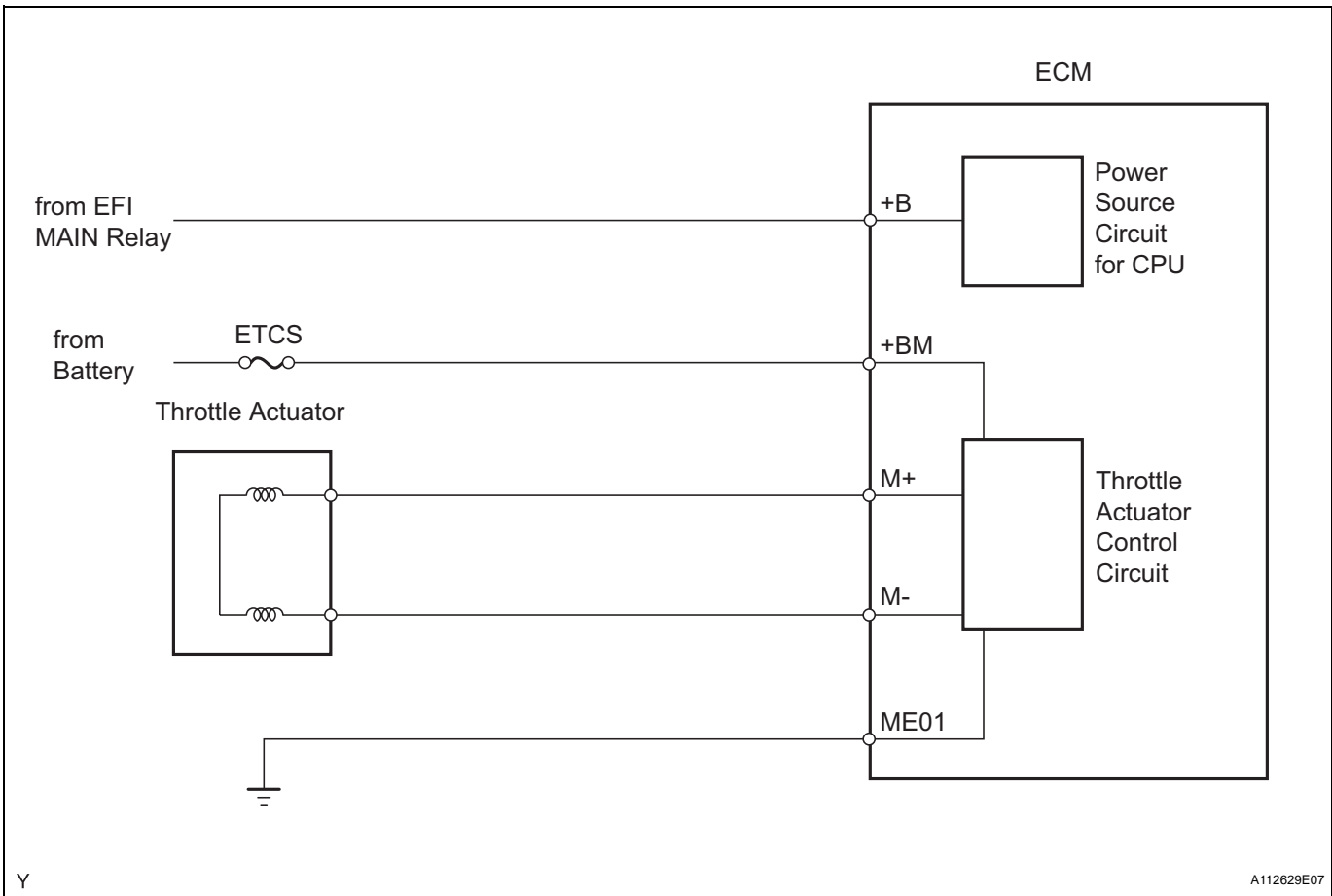

DTC No.	DTC Detection Condition	Trouble Area
P2118	Open in ETCS power source (+BM) circuit (1 trip detection logic)	<ul style="list-style-type: none"> Open in ETCS power source circuit Battery Battery terminals ETCS fuse ECM

MONITOR DESCRIPTION

The ECM monitors the battery supply voltage applied to the throttle actuator. When the power supply voltage (+BM) drops below 4 V for 0.8 seconds or more, the ECM interprets this as an open in the power supply circuit (+BM). The ECM illuminates the MIL and sets the DTC. If the malfunction is not repaired successfully, the DTC is set 5 seconds after the engine is next started.

MONITOR STRATEGY

Related DTCs	P2118: Throttle actuator power supply
Required Sensors/Components (Main)	Throttle actuator, throttle valve, ETCS fuse
Required Sensors/Components (Related)	None
Frequency of Operation	Continuous
Duration	0.8 seconds
MIL Operation	Immediate
Sequence of Operation	None

TYPICAL ENABLING CONDITIONS

Monitor runs whenever following DTCs not present	None
Battery voltage	8 V or more
Electronic throttle actuator power	ON

TYPICAL MALFUNCTION THRESHOLDS

Throttle actuator power supply voltage (+BM)	Less than 4 V
--	---------------

COMPONENT OPERATING RANGE

Throttle actuator power supply voltage (+BM)	9 to 14 V
--	-----------

FAIL-SAFE

When this DTC, or other DTCs relating to ETCS (Electronic Throttle Control System) malfunctions, are set, the ECM enters fail-safe mode. During fail-safe mode, the ECM cuts the current to the throttle actuator off, and the throttle valve is returned to a 6° throttle angle by the return spring. The ECM then adjusts the engine output by controlling the fuel injection (intermittent fuel-cut) and ignition timing, in accordance with the accelerator pedal opening angle, to allow the vehicle to continue at a minimal speed. If the accelerator pedal is depressed firmly and gently, the vehicle can be driven slowly. Fail-safe mode continues until a pass condition is detected, and the ignition switch is then turned OFF.

WIRING DIAGRAM

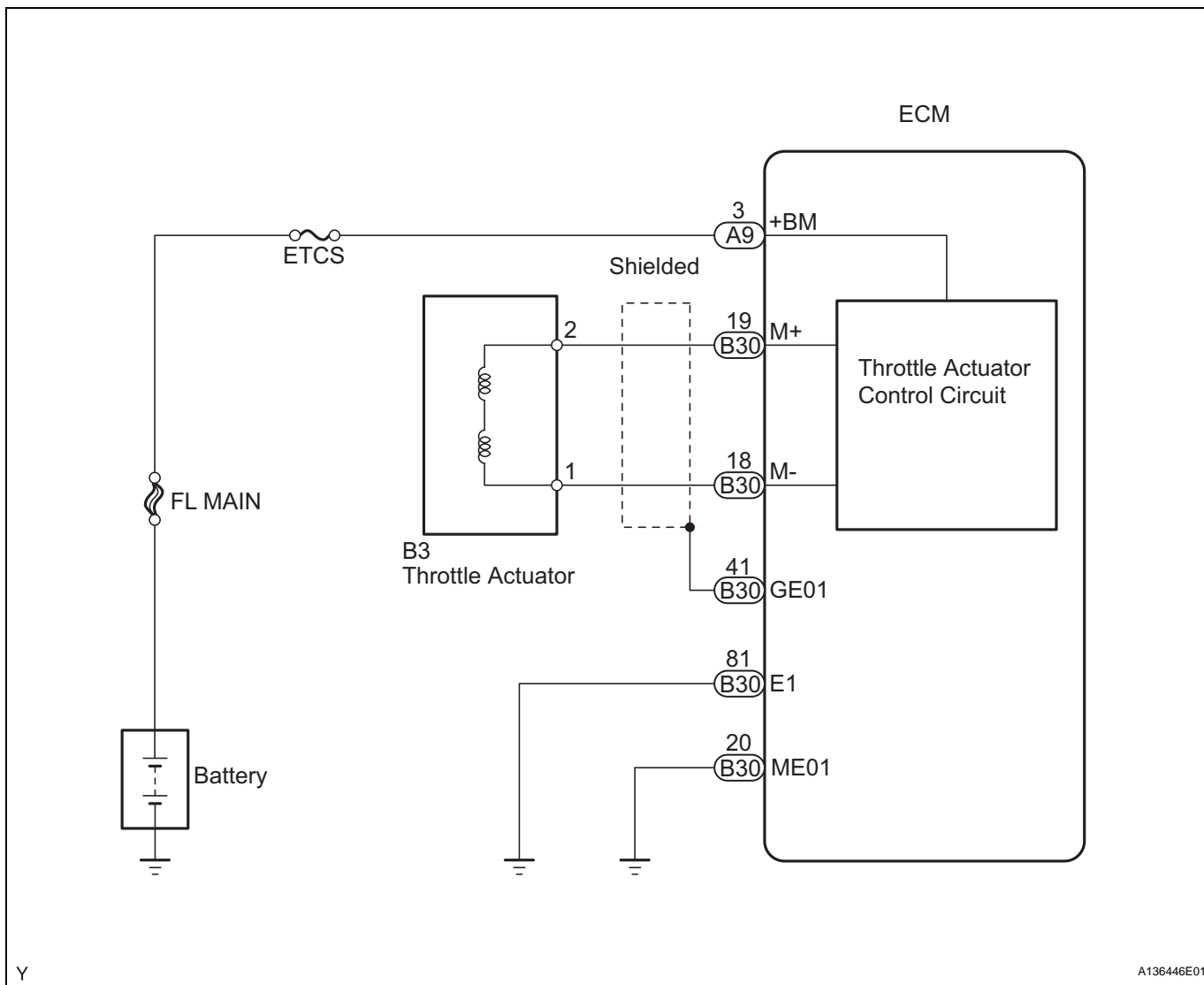

INSPECTION PROCEDURE

HINT:

Read freeze frame data using the intelligent tester. Freeze frame data records the engine condition when malfunctions are detected. When troubleshooting, freeze frame data can help determine if the vehicle was moving or stationary, if the engine was warmed up or not, if the air-fuel ratio was lean or rich, and other data from the time the malfunction occurred.

1

READ VALUE USING INTELLIGENT TESTER (+BM VOLTAGE)

- (a) Connect the intelligent tester to the DLC3.
- (b) Turn the ignition switch ON.
- (c) Turn the tester ON.
- (d) Select the following menu items: DIAGNOSIS / ENHANCED OBD II / DATA LIST / +BM VOLTAGE.
- (e) Read the value displayed on the tester.

Standard voltage:

9 to 14 V

OK

Go to step 5

NG

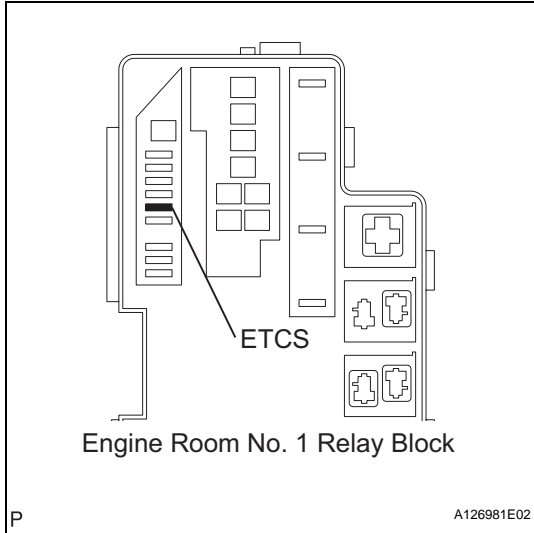
2 CHECK FUSE (ETCS FUSE)

- (a) Remove the ETCS fuse from the engine room No. 1 relay block.
- (b) Measure the ETCS fuse resistance.
Standard resistance:
Below 1 Ω
- (c) Reinstall the ETCS fuse.

NG

CHECK FOR SHORTS IN ALL HARNESSSES AND CONNECTORS CONNECTED TO FUSE AND REPLACE FUSE

ES

OK

3 CHECK WIRE HARNESS (ECM - ETCS FUSE, ETCS FUSE - BATTERY)

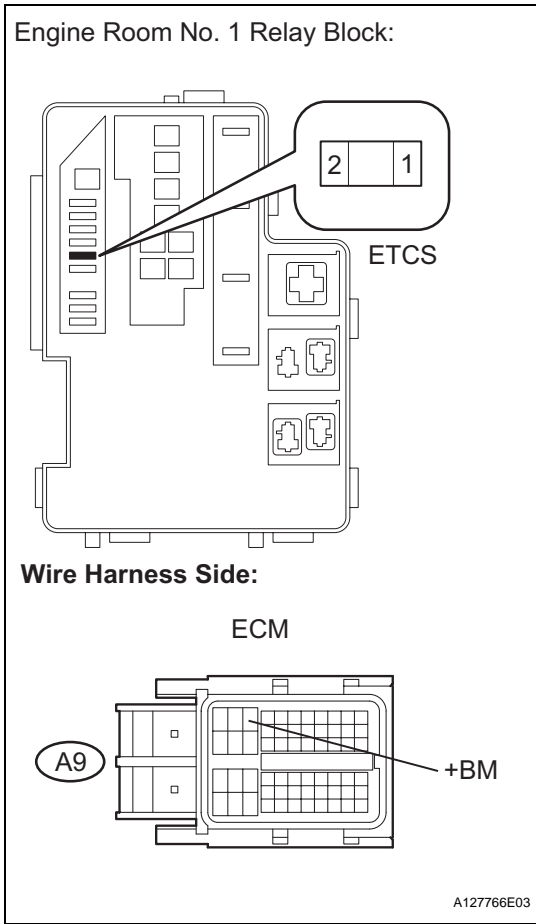

- (a) Check the harness and connector between the ETCS fuse and ECM.
- (1) Remove the ETCS fuse from the engine room No. 1 relay block.
 - (2) Disconnect the A9 ECM connector.
 - (3) Measure the resistance.

Standard resistance

Tester Connection	Specified Condition
ETCS fuse terminal 2 - A9-3 (+BM)	Below 1 Ω
ETCS fuse terminal 2 or A9-3 (+BM) - Body ground	10 kΩ or higher

- (4) Reinstall the ETCS fuse.
 - (5) Reconnect the ECM connector.
- (b) Check the harness and connector between the ETCS fuse and positive battery cable.
- (1) Remove the ETCS fuse from the engine room No. 1 relay block.
 - (2) Disconnect the cable from the positive (+) battery terminal.
 - (3) Check the resistance.

Standard resistance

Tester Connection	Specified Condition
Positive battery cable - ETCS fuse terminal 1	Below 1 Ω
Positive battery cable or ETCS fuse terminal 1 - Body ground	10 kΩ or higher

- (4) Reinstall the ETCS fuse.
- (5) Reconnect the cable to the positive (+) battery terminal.

NG **REPAIR OR REPLACE HARNESS AND CONNECTOR**

OK

ES

4 INSPECT ECM (+BM VOLTAGE)

Wire Harness Side:

(B30) ECM

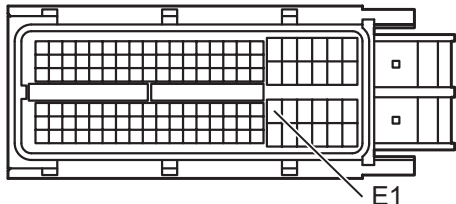

(A9) ECM

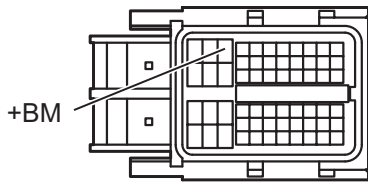

A106902E08

- (a) Disconnect the A9 and B30 ECM connectors.
- (b) Measure the voltage between the terminals of the A9 and B30 ECM connectors.

Standard voltage

Tester Connection	Specified Condition
A9-3 (+BM) - B30-81 (E1)	9 to 14 V

- (c) Reconnect the ECM connectors.

NG

REPAIR OR REPLACE HARNESS AND CONNECTOR (TERMINAL E1 - BODY GROUND)

ES

OK

REPLACE ECM

5 INSPECT BATTERY

- (a) Check that the battery is not depleted.

OK:

Battery is not depleted

NG

REPLACE BATTERY

OK

6 CHECK BATTERY TERMINAL

- (a) Check that the battery terminals and ECM ground are not loose or corroded.

OK:

Battery terminals and ECM ground are not loose or corroded

NG

REPAIR OR REPLACE BATTERY TERMINAL

OK

CHECK FOR INTERMITTENT PROBLEMS