

<b>DTC</b>	<b>P0450</b>	<b>Evaporative Emission Control System Pressure Sensor / Switch</b>
<b>DTC</b>	<b>P0451</b>	<b>Evaporative Emission Control System Pressure Sensor Range / Performance</b>
<b>DTC</b>	<b>P0452</b>	<b>Evaporative Emission Control System Pressure Sensor / Switch Low Input</b>
<b>DTC</b>	<b>P0453</b>	<b>Evaporative Emission Control System Pressure Sensor / Switch High Input</b>

ES

**DTC SUMMARY**

<b>DTC</b>	<b>Monitoring Item</b>	<b>Malfunction Detection Condition</b>	<b>Trouble Area</b>	<b>Detection Timing</b>	<b>Detection Logic</b>
P0450	Canister pressure sensor voltage fluctuation abnormal	Sensor output voltage rapidly fluctuates beyond upper and lower malfunction thresholds for 0.5 seconds.	<ul style="list-style-type: none"> <li>• Canister pump module</li> <li>• EVAP system hose (pipe from air inlet port to canister pump module, canister filter, fuel tank vent hose)</li> <li>• ECM</li> </ul>	<ul style="list-style-type: none"> <li>• EVAP monitoring (ignition switch OFF)</li> <li>• Ignition switch ON</li> </ul>	1 trip
P0451	Canister pressure sensor noise	Sensor output voltage fluctuates frequently within certain time period.	<ul style="list-style-type: none"> <li>• Canister pump module</li> <li>• Connector/wire harness (Canister pump module - ECM)</li> <li>• EVAP system hose (pipe from air inlet port to canister pump module, canister filter, fuel tank vent hose)</li> <li>• ECM</li> </ul>	<ul style="list-style-type: none"> <li>• EVAP monitoring (ignition switch OFF)</li> <li>• Engine running</li> </ul>	2 trip
	Canister pressure sensor signal becomes fixed/flat	Sensor output voltage does not vary within certain time period.	<ul style="list-style-type: none"> <li>• Canister pump module</li> <li>• Connector/wire harness (Canister pump module - ECM)</li> <li>• EVAP system hose (pipe from air inlet port to canister pump module, canister filter, fuel tank vent hose)</li> <li>• ECM</li> </ul>	<ul style="list-style-type: none"> <li>• EVAP monitoring (ignition switch OFF)</li> </ul>	2 trip
P0452	Canister pressure sensor low input	EVAP pressure less than 42.1 kPa for 0.5 seconds.	<ul style="list-style-type: none"> <li>• Canister pump module</li> <li>• Connector/wire harness (Canister pump module - ECM)</li> <li>• EVAP system hose (pipe from air inlet port to canister pump module, canister filter, fuel tank vent hose)</li> <li>• ECM</li> </ul>	<ul style="list-style-type: none"> <li>• Ignition switch ON</li> <li>• EVAP monitoring (ignition switch OFF)</li> </ul>	1 trip

DTC	Monitoring Item	Malfunction Detection Condition	Trouble Area	Detection Timing	Detection Logic
P0453	Canister pressure sensor high input	EVAP pressure more than 123.8 kPa for 0.5 seconds.	<ul style="list-style-type: none"> <li>• Canister pump module</li> <li>• Connector/wire harness (Canister pump module - ECM)</li> <li>• EVAP system hose (pipe from air inlet port to canister pump module, canister filter, fuel tank vent hose)</li> <li>• ECM</li> </ul>	<ul style="list-style-type: none"> <li>• Ignition switch ON</li> <li>• EVAP monitoring (ignition switch OFF)</li> </ul>	1 trip

**HINT:**

The canister pressure sensor is built into the canister pump module.

**ES**

**DESCRIPTION**

The description can be found in the EVAP (Evaporative Emission) System (see page [ES-371](#)).

**MONITOR DESCRIPTION**

**Canister Pressure Sensor Specification:**

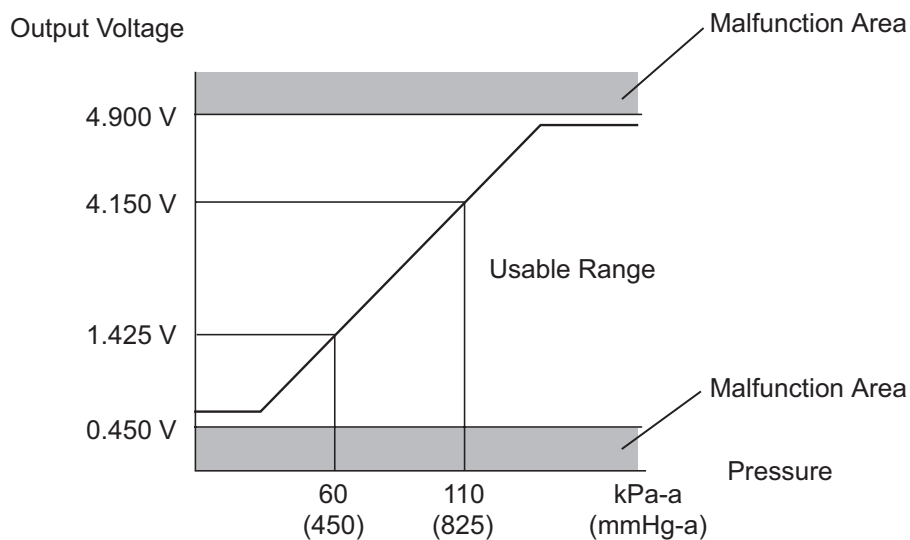

**HINT:**

Standard atmospheric pressure is 101.3 kPa-a (760 mmHg-a)

A115543E05

**1. DTC P0450: Canister pressure sensor abnormal fluctuation**

If the canister pressure sensor output [pressure] rapidly fluctuates between less than 42.1 kPa-a (315.9 mmHg-a) and more than 123.8 kPa-a (928.4 mmHg-a), the ECM interprets this as an open or short circuit malfunction in the canister pressure sensor or its circuit, and stops the EVAP (Evaporative Emission) system monitor. The ECM then illuminates the MIL and sets the DTC (1 trip detection logic).

2. DTC P0451: Canister pressure sensor noise or fixed/flat  
If the canister pressure sensor voltage output fluctuates rapidly for 10 seconds, the ECM stops the EVAP system monitor. The ECM interprets this as noise from the canister pressure sensor, and stops the EVAP system monitor. The ECM then illuminates the MIL and sets the DTC.  
Alternatively, if the sensor voltage output does not change for 10 seconds, the ECM interprets this as the sensor being fixed/flat, and stops the monitor. The ECM then illuminates the MIL and sets the DTC. (Both the malfunctions are detected by 2 trip detection logic.)
3. DTC P0452: Canister pressure sensor voltage low  
If the canister pressure sensor output [pressure] is below 42.1 kPa-a (315.9 mmHg-a), the ECM interprets this as an open or short circuit malfunction in the canister pressure sensor or its circuit, and stops the EVAP system monitor. The ECM then illuminates the MIL and sets the DTC (1 trip detection logic).
4. DTC P0453: Canister pressure sensor voltage high  
If the canister pressure sensor output [pressure] is 123.8 kPa-a (928.4 mmHg-a) or more, the ECM interprets this as an open or short circuit malfunction in the canister pressure sensor or its circuit, and stops the EVAP system monitor. The ECM then illuminates the MIL and sets the DTC (1 trip detection logic).

## MONITOR STRATEGY

Required Sensors/Components	Canister pump module
Frequency of Operation	Once per driving cycle: P0451 sensor fixed/flat Continuous: P0451 sensor noise, P0450, P0452 and P0453
Duration	0.5 seconds: P0450, P0452 and P0453 2 minutes: P0451
MIL Operation	Immediate: P0450, P0452 and P0453 2 driving cycles: P0451
Sequence of Operation	None

## TYPICAL ENABLING CONDITIONS

### P0451 (Noise monitor):

Monitor runs whenever following DTCs not present	None
Atmospheric pressure (absolute pressure)	70 to 110 kPa-a (525 to 825 mmHg-a)
Battery voltage	10.5 V or more
Intake air temperature	4.4 to 35°C (40 to 95°F)
Canister pressure sensor malfunction (P0450, P0452, 0453)	Not detected
Either of following conditions met	A or B
A. Engine condition	Running
B. Time after key off	5 or 7 or 9.5 hours

### P0451 (Fixed/flat monitor):

Monitor runs whenever following DTCs not present	None
Battery voltage	10.5 V or more
Intake air temperature	4.4 to 35°C (40 to 95°F)
Canister pressure sensor malfunction (P0450, P0452, 0453)	Not detected
Atmospheric pressure (absolute pressure)	70 to 110 kPa-a (525 to 825 mmHg-a)
Time after key off	5 or 7 or 9.5 hours

### P0450, P0452 and P0453:

Monitor runs whenever following DTCs not present	None
Either of following conditions met	(a) or (b)
(a) Ignition switch	ON
(b) Soak timer	ON

**TYPICAL MALFUNCTION THRESHOLDS****P0450: Canister pressure sensor chattering**

EVAP pressure	Less than 42.1 kPa-a (315.9 mmHg-a), or more than 123.8 kPa-a (928.4 mmHg-a)
---------------	--

**P0451: Canister pressure sensor noise**

Frequency that EVAP pressure change 0.3 kPa-g (2.25 mmHg-g) or more	10 times or more in 10 seconds
---	--------------------------------

**P0451: Canister pressure sensor fixed/flat**

EVAP pressure change during reference pressure	Less than 0.65 kPa-g (4.87 mmHg-g)
--	------------------------------------

**P0452: Canister pressure sensor low voltage**

EVAP pressure	Less than 42.1 kPa-a (315.9 mmHg-a)
---------------	-------------------------------------

**ES****P0453: Canister pressure sensor high voltage**

EVAP pressure	More than 123.8 kPa-a (928.4 mmHg-a)
---------------	--------------------------------------

**WIRING DIAGRAM**

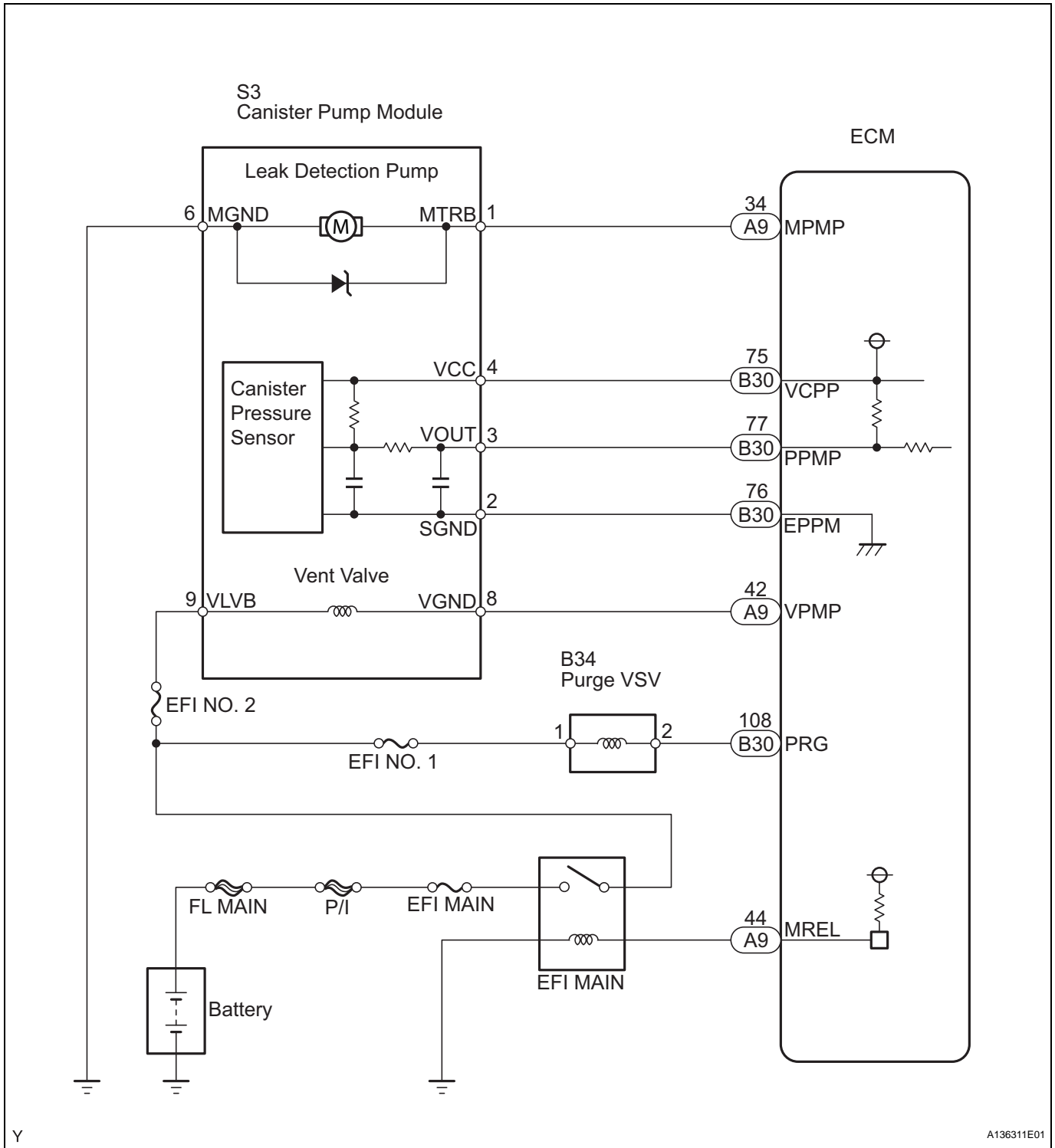

**ES**

**INSPECTION PROCEDURE**

**NOTICE:**

- When a vehicle is brought into the workshop, leave it as it is. Do not change the vehicle condition. For example, do not tighten the fuel cap.
- Do not disassemble the canister pump module.
- The intelligent tester is required to conduct the following diagnostic troubleshooting procedure.

Y

A136311E01

**1 CONFIRM DTC AND EVAP PRESSURE**

- (a) Connect the intelligent tester to the DLC3.
- (b) Turn the ignition switch ON (do not start the engine).
- (c) Turn the tester ON.
- (d) Select the following menu items: DIAGNOSIS / ENHANCED OBD II / DTC INFO / CURRENT CODES.
- (e) Read DTCs.
- (f) Select the following menu items: DIAGNOSIS / ENHANCED OBD II / DATA LIST / EVAP / EVAP VAPOR PRESS.
- (g) Read the EVAP (Evaporative Emission) pressure displayed on the tester.

**ES Result**

Display (DTC Output)	Test Result	Suspected Trouble Area	Proceed to
P0451	-	Canister pressure sensor	C
P0452	Less than 45 kPa-a (430 mmHg-a)	<ul style="list-style-type: none"> <li>• Wire harness/connector (ECM - Canister pressure sensor)</li> <li>• Canister pressure sensor</li> <li>• Short in ECM circuit</li> </ul>	A
P0453	More than 120 kPa-a (900 mmHg-a)	<ul style="list-style-type: none"> <li>• Wire harness/connector (ECM - Canister pressure sensor)</li> <li>• Canister pressure sensor</li> <li>• Open in ECM circuit</li> </ul>	B

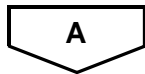
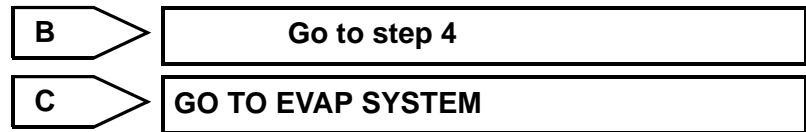

**2 CHECK WIRE HARNESS (CANISTER PUMP MODULE - ECM)**

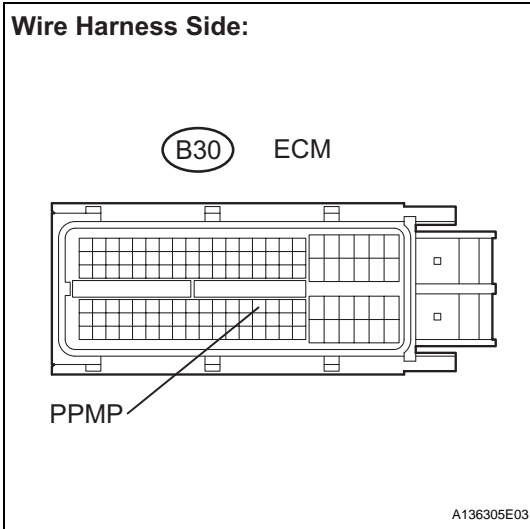

- (a) Turn the ignition switch OFF.
- (b) Disconnect the B30 ECM connector.
- (c) Measure the resistance between PPMP terminal of the ECM connector and the body ground.

**Result**

Test Result	Suspected Trouble Area	Proceed to
10 Ω or less	<ul style="list-style-type: none"> <li>• Wire harness/connector (ECM - Canister pressure sensor)</li> <li>• Short in canister pressure sensor circuit</li> </ul>	A
10 kΩ or more	<ul style="list-style-type: none"> <li>• Wire harness/connector (ECM - Canister pressure sensor)</li> <li>• Short in ECM circuit</li> </ul>	B

(d) Reconnect the ECM connector.



**3 CHECK WIRE HARNESS (CANISTER PUMP MODULE - ECM)**

**ES**

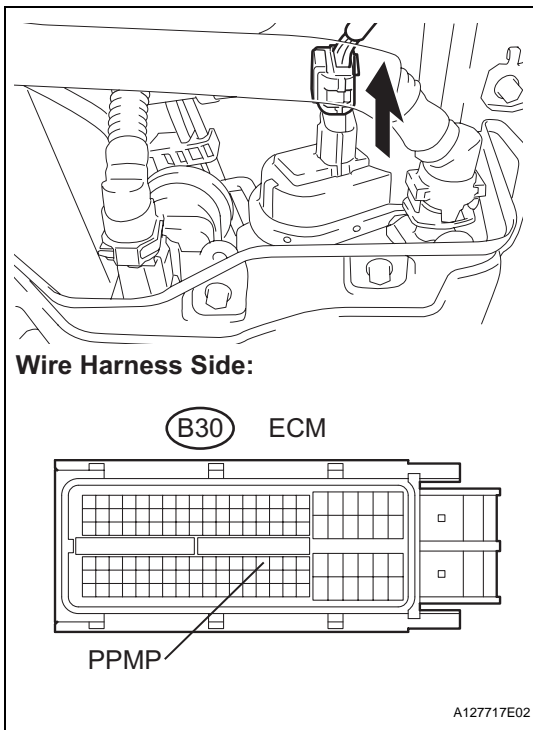

- (a) Disconnect the S3 canister pump module connector.
- (b) Disconnect the B30 ECM connector.
- (c) Measure the resistance between PPMP terminal of the ECM connector and the body ground.

**Result**

Test Result	Suspected Trouble Area	Proceed to
10 kΩ or more	Short in canister pressure sensor circuit	A
10 Ω or less	Short in wire harness/connector (ECM - Canister pressure sensor)	B

- (d) Reconnect the canister pump module connector.
- (e) Reconnect the ECM connector.



**4 CHECK WIRE HARNESS (CANISTER PUMP MODULE - ECM)**

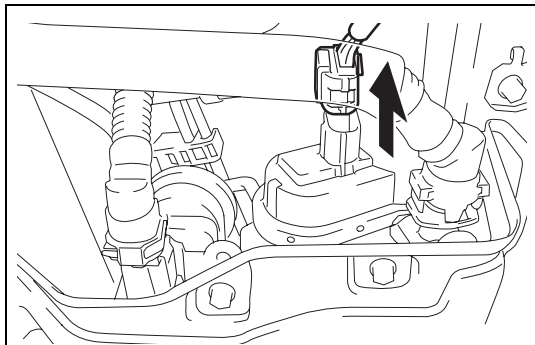

- (a) Disconnect the S3 canister pump module connector.
- (b) Turn the ignition switch ON.
- (c) Measure the voltage and resistance of the canister connector.

**Standard**

Tester Connection	Specified Condition
S3-4 (VCC) - Body ground	4.5 to 5.5 V
S3-3 (VOUT) - Body ground	4.5 to 5.5 V
S3-2 (SGND) - Body ground	100 Ω or less

Wire Harness Side:

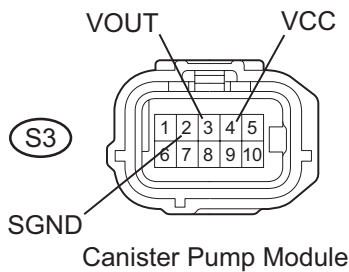

A127718E05

**Result**

Test Result	Suspected Trouble Area	Proceed to
Voltage and resistance within standard ranges	Open in canister pressure sensor circuit	A
Voltage and resistance outside standard ranges	Open in wire harness/connector (ECM - Canister pressure sensor)	B

- (d) Reconnect the canister pump module connector.

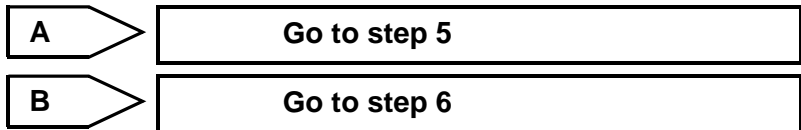

**5 REPLACE CHARCOAL CANISTER ASSEMBLY**

- (a) Replace the canister assembly (see page [EC-10](#)).  
**NOTICE:**  
 When replacing the canister, check the canister pump module interior and related pipes for water, fuel and other liquids. If liquids are present, check for disconnections and/or cracks in the following: 1) the pipe from the air inlet port to the canister pump module; 2) the canister filter; and 3) the fuel tank vent hose.



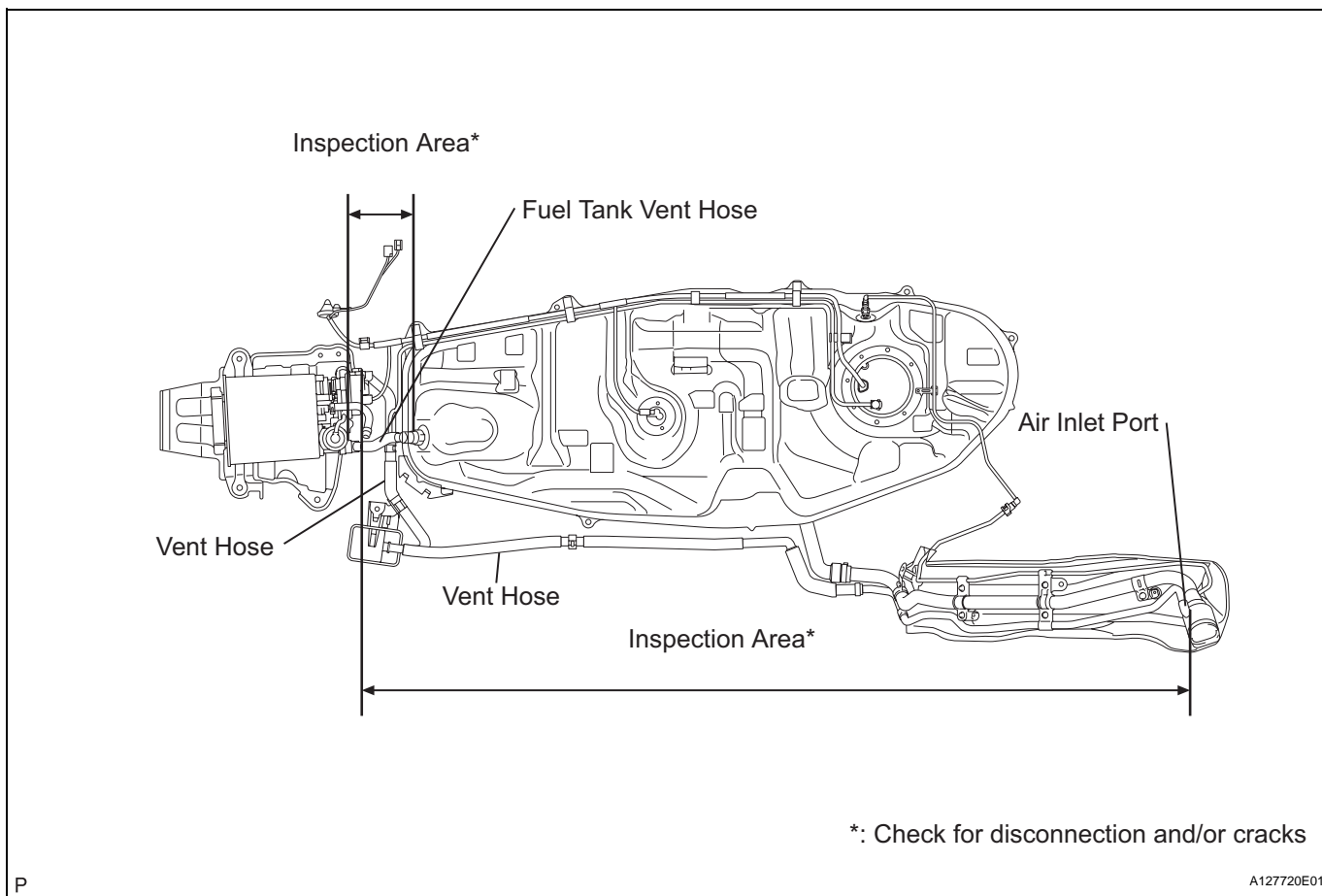

ES

NEXT

Go to step 8

6

REPAIR OR REPLACE HARNESS AND CONNECTOR

HINT:

If the exhaust tailpipe has been removed, go to the next step before reinstalling it.

NEXT

Go to step 8

7

REPLACE ECM

(a) Replace the ECM (see page [ES-429](#)).

NEXT

Go to step 8

8

CHECK WHETHER DTC OUTPUT RECURS (AFTER REPAIR)

- Connect the intelligent tester to the DLC3.
- Turn the ignition switch ON and turn the tester ON.
- Wait for at least 60 seconds.
- On the tester, select the following menu items:  
DIAGNOSIS / ENHANCED OBD II / DTC INFO / PENDING CODES.

**HINT:**

If no pending DTCs are displayed on the tester, the repair has been successfully completed.

A button with a downward-pointing arrow shape and the word "NEXT" inside.

**NEXT**

A rectangular button with the word "COMPLETED" inside.

**COMPLETED**