

<b>DTC</b>	<b>P0115</b>	<b>Engine Coolant Temperature Circuit Malfunction</b>
<b>DTC</b>	<b>P0117</b>	<b>Engine Coolant Temperature Circuit Low Input</b>
<b>DTC</b>	<b>P0118</b>	<b>Engine Coolant Temperature Circuit High Input</b>

## DESCRIPTION

A thermistor, whose resistance value varies according to the ECT, is built into the Engine Coolant Temperature (ECT) sensor.

The structure of the sensor and its connection to the ECM are the same as those of the Intake Air Temperature (IAT) sensor.

HINT:

When any of DTCs P0115, P0117 and P0118 are set, the ECM enters fail-safe mode. During fail-safe mode, the ECT is estimated to be 80°C (176°F) by the ECM. Fail-safe mode continues until a pass condition is detected.

DTC No.	DTC Detection Condition	Trouble Area
P0115	Open or short in ECT sensor circuit for 0.5 seconds (1 trip detection logic)	<ul style="list-style-type: none"> <li>Open or short in ECT sensor circuit</li> <li>ECT sensor</li> <li>ECM</li> </ul>
P0117	Short in ECT sensor circuit for 0.5 seconds (1 trip detection logic)	<ul style="list-style-type: none"> <li>Short in ECT sensor</li> <li>ECT sensor</li> <li>ECM</li> </ul>
P0118	Open in ECT sensor circuit for 0.5 seconds (1 trip detection logic)	<ul style="list-style-type: none"> <li>Open in ECT sensor circuit</li> <li>ECT sensor</li> <li>ECM</li> </ul>

HINT:

When any of these DTCs are set, check the ECT by selecting the following menu items on the intelligent tester: DIAGNOSIS / ENHANCED OBD II / DATA LIST / PRIMARY / COOLANT TEMP.

Temperature Displayed	Malfunction
-40°C (-40°F)	Open circuit
140°C (284°F) or higher	Short circuit

## MONITOR DESCRIPTION

The Engine Coolant Temperature (ECT) sensor is used to monitor the ECT. The ECT sensor has a thermistor with a resistance that varies according to the temperature of the engine coolant. When the coolant temperature is low, the resistance in the thermistor increases. When the temperature is high, the resistance drops. These variations in resistance are reflected in the output voltage from the sensor. The ECM monitors the sensor voltage and uses this value to calculate the ECT. When the sensor output voltage deviates from the normal operating range, the ECM interprets this as a fault in the ECT sensor and sets a DTC.

Example:

If the sensor output voltage is more than 4.91 V for 0.5 seconds or more, the ECM determines that there is an open in the ECT sensor circuit, and sets DTC P0118. Conversely, if the voltage output is less than 0.14 V for 0.5 seconds or more, the ECM determines that there is a short in the sensor circuit, and sets DTC P0117.

If the malfunction is not repaired successfully, a DTC is set 0.5 seconds after the engine is next started.

### MONITOR STRATEGY

Related DTCs	P0115: ECT sensor range check (Fluctuating) P0117: ECT sensor range check (Low voltage) P0118: ECT sensor range check (High voltage)
Required Sensors/Components (Main)	ECT sensor
Required Sensors/Components (Related)	-
Frequency of Operation	Continuous
Duration	0.5 seconds
MIL Operation	Immediate
Sequence of Operation	None

### TYPICAL ENABLING CONDITIONS

Monitor runs whenever following DTCs not present	None
--	------

ES

### TYPICAL MALFUNCTION THRESHOLDS

**P0115:**

ECT sensor voltage	Less than 0.14 V, or more than 4.91 V
--------------------	---------------------------------------

**P0117:**

ECT sensor voltage [ECT]	Less than 0.14 V [More than 140°C (284°F)]
--------------------------	--

**P0118:**

ECT sensor voltage [ECT]	More than 4.91 V [Less than -40°C (-40°F)]
--------------------------	--

### COMPONENT OPERATING RANGE

ECT sensor voltage [ECT]	0.14 to 4.91 V [-40°C to 140°C (-40°F to 284°F)]
--------------------------	--

### WIRING DIAGRAM

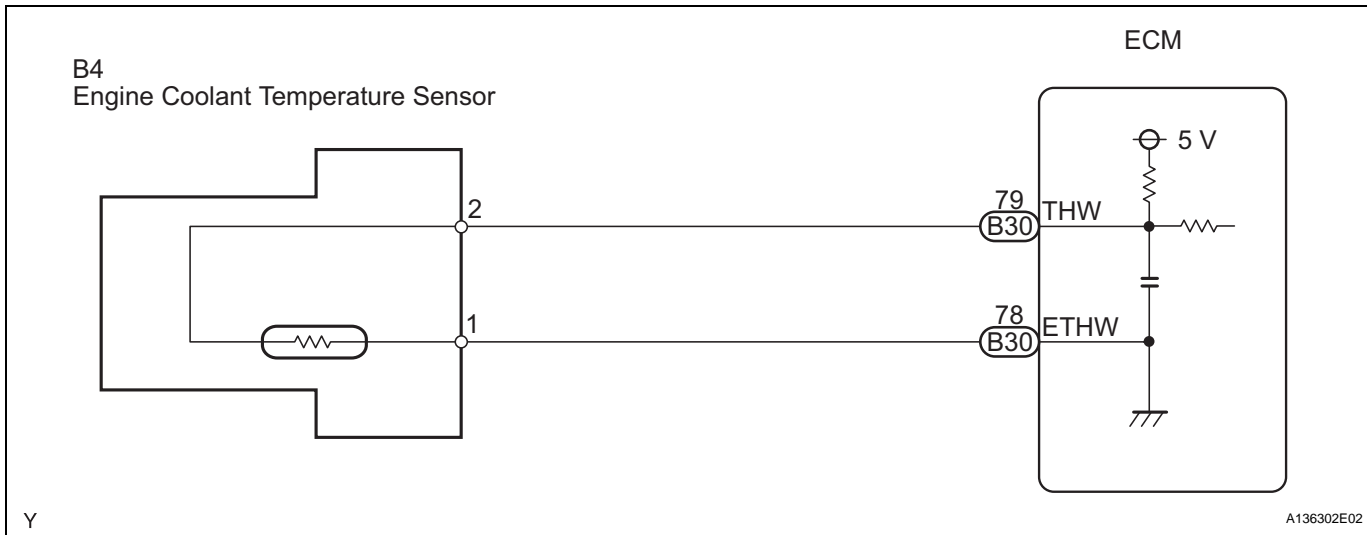

Y

## INSPECTION PROCEDURE

**HINT:**

Read freeze frame data using the intelligent tester. Freeze frame data records the engine condition when malfunctions are detected. When troubleshooting, freeze frame data can help determine if the vehicle was moving or stationary, if the engine was warmed up or not, if the air-fuel ratio was lean or rich, and other data from the time the malfunction occurred.

<b>1</b>	<b>READ OUTPUT DTC</b>
----------	------------------------

- (a) Connect the intelligent tester to the DLC3.
- (b) Turn the ignition switch ON and turn the intelligent tester ON.
- (c) Select the following menu items: DIAGNOSIS / ENHANCED OBD II / DTC INFO / CURRENT CODES.
- (d) Read DTCs.

**Result**

Display (DTC Output)	Proceed to
P0115	A
P0117	B
P0118	C

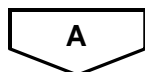
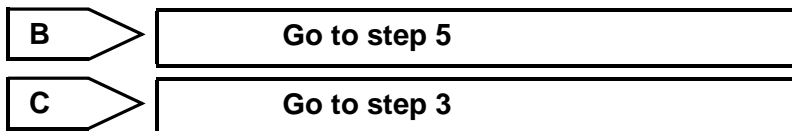

<b>2</b>	<b>READ VALUE USING INTELLIGENT TESTER (ENGINE COOLANT TEMPERATURE)</b>
----------	---

- (a) Connect the intelligent tester to the DLC3.
- (b) Turn the ignition switch ON.
- (c) Turn the tester ON.
- (d) Select the following menu items: DIAGNOSIS / ENHANCED OBD II / DATA LIST / PRIMARY / COOLANT TEMP.
- (e) Read the value displayed on the tester.

**Standard value:**

**Between 80°C and 100°C (167°F and 212°F) with warm engine.**

**Result**

Temperature Displayed	Proceed to
-40°C (-40°F)	A
140°C (284°F) or higher	B
Between 80°C and 100°C (176°F and 212°F)	C

**HINT:**

- If there is an open circuit, the intelligent tester indicates -40°C (-40°F).
- If there is a short circuit, the intelligent tester indicates 140°C (284°F) or higher.



**C** CHECK FOR INTERMITTENT PROBLEMS

**A**

**3** READ VALUE USING INTELLIGENT TESTER (CHECK FOR OPEN IN WIRE HARNESS)

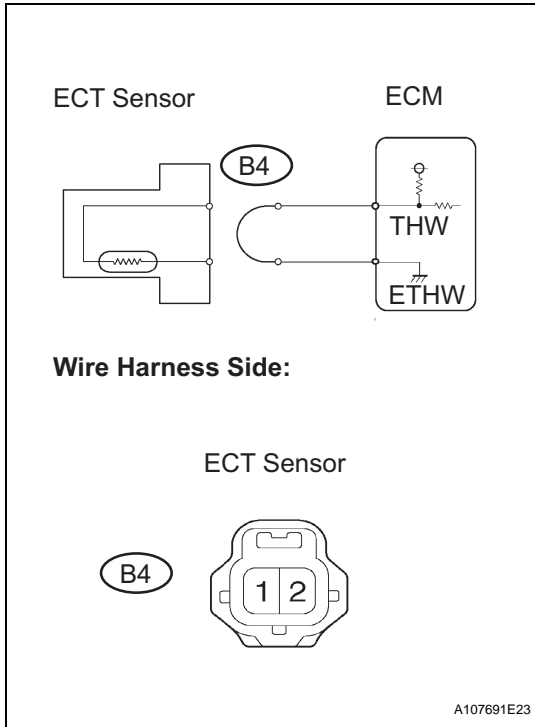

- (a) Disconnect the B4 Engine Coolant Temperature (ECT) sensor connector.
- (b) Connect terminals 1 and 2 of the ECT sensor connector on the wire harness side.
- (c) Connect the intelligent tester to the DLC3.
- (d) Turn the ignition switch ON.
- (e) Turn the tester ON.
- (f) Select the following menu items: DIAGNOSIS / ENHANCED OBD II / DATA LIST / PRIMARY / COOLANT TEMP.
- (g) Read the value displayed on the tester.  
**Standard value:**  
**140°C (284°F) or higher.**
- (h) Reconnect the ECT sensor connector.

**OK** CONFIRM GOOD CONNECTION TO SENSOR. IF OK, REPLACE ENGINE COOLANT TEMPERATURE SENSOR

**NG**

**ES**

**4 CHECK WIRE HARNESS (ENGINE COOLANT TEMPERATURE SENSOR - ECM)**

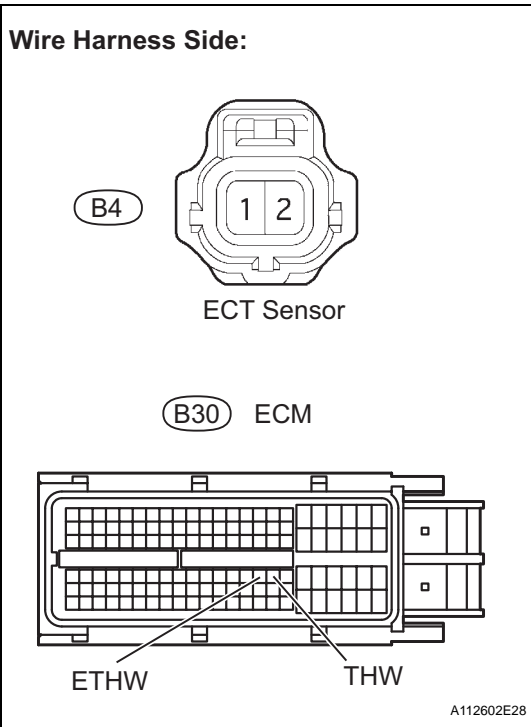

- (a) Disconnect the B4 ECT sensor connector.
- (b) Disconnect the B30 ECM connector.
- (c) Measure the resistance.

**Standard resistance**

Tester Connection	Specified Condition
B4-2 - B30-79 (THW)	Below 1 Ω
B4-1 - B30-78 (ETHW)	Below 1 Ω

- (d) Reconnect the ECT sensor connector.
- (e) Reconnect the ECM connector.

**NG** REPAIR OR REPLACE HARNESS AND CONNECTOR

**ES**

**OK**

**GOOD CONNECTION TO ECM. IF OK, REPLACE ECM**

**5 READ VALUE USING INTELLIGENT TESTER (CHECK FOR SHORT IN WIRE HARNESS)**

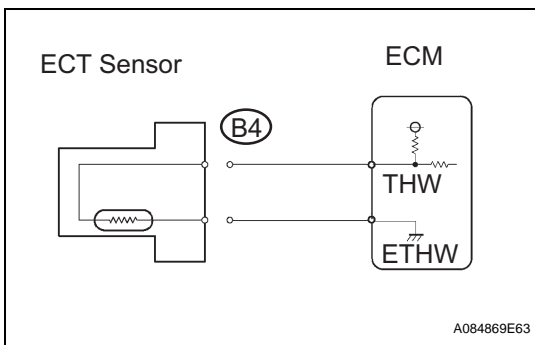

- (a) Disconnect the B4 ECT sensor connector.
- (b) Connect the intelligent tester to the DLC3.
- (c) Turn the ignition switch ON.
- (d) Turn the tester ON.
- (e) Select the following menu items: DIAGNOSIS / ENHANCED OBD II / DATA LIST / PRIMARY / COOLANT TEMP.
- (f) Read the value displayed on the tester.

**Standard value:**

**-40°C (-40°F)**

- (g) Reconnect the ECT sensor connector.

**OK** REPLACE ENGINE COOLANT TEMPERATURE SENSOR

**NG**

**6 CHECK WIRE HARNESS (ENGINE COOLANT TEMPERATURE SENSOR - ECM)**

Wire Harness Side:

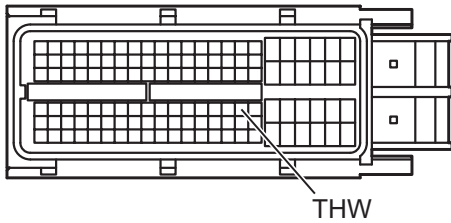
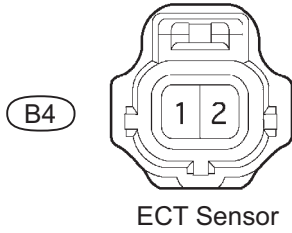

A112602E29

- (a) Disconnect the B4 ECT sensor connector.
- (b) Disconnect the B30 ECM connector.
- (c) Measure the resistance.

**Standard resistance**

Tester Connection	Specified Condition
B4-2 or B30-79 (THW) - Body ground	10 kΩ or higher

- (d) Reconnect the ECT sensor connector.
- (e) Reconnect the ECM connector.

**NG** **REPAIR OR REPLACE HARNESS AND CONNECTOR**

**ES**

**OK**

**REPLACE ECM**