

DTC	P0100	Mass or Volume Air Flow Circuit
DTC	P0102	Mass or Volume Air Flow Circuit Low Input
DTC	P0103	Mass or Volume Air Flow Circuit High Input

DESCRIPTION

The Mass Air Flow (MAF) meter is a sensor that measures the amount of air flowing through the throttle valve.

The ECM uses this information to determine the fuel injection time and to provide the appropriate air-fuel ratio.

Inside the MAF meter, there is a heated platinum wire which is exposed to the flow of intake air.

By applying a specific electrical current to the wire, the ECM heats it to a given temperature. The flow of incoming air cools both the wire and an internal thermistor, affecting their resistance. To maintain a constant current value, the ECM varies the voltage applied to these components in the MAF meter. The voltage level is proportional to the airflow through the sensor, and the ECM uses it to calculate the intake air volume.

The circuit is constructed so that the platinum hot wire and the temperature sensor create a bridge circuit, and the power transistor is controlled so that the potentials of A and B remain equal to maintain the predetermined temperature.

HINT:

When any of these DTCs are set, the ECM enters fail-safe mode. During fail-safe mode, the ignition timing is calculated by the ECM, according to the engine RPM and throttle valve position. Fail-safe mode continues until a pass condition is detected.

ES

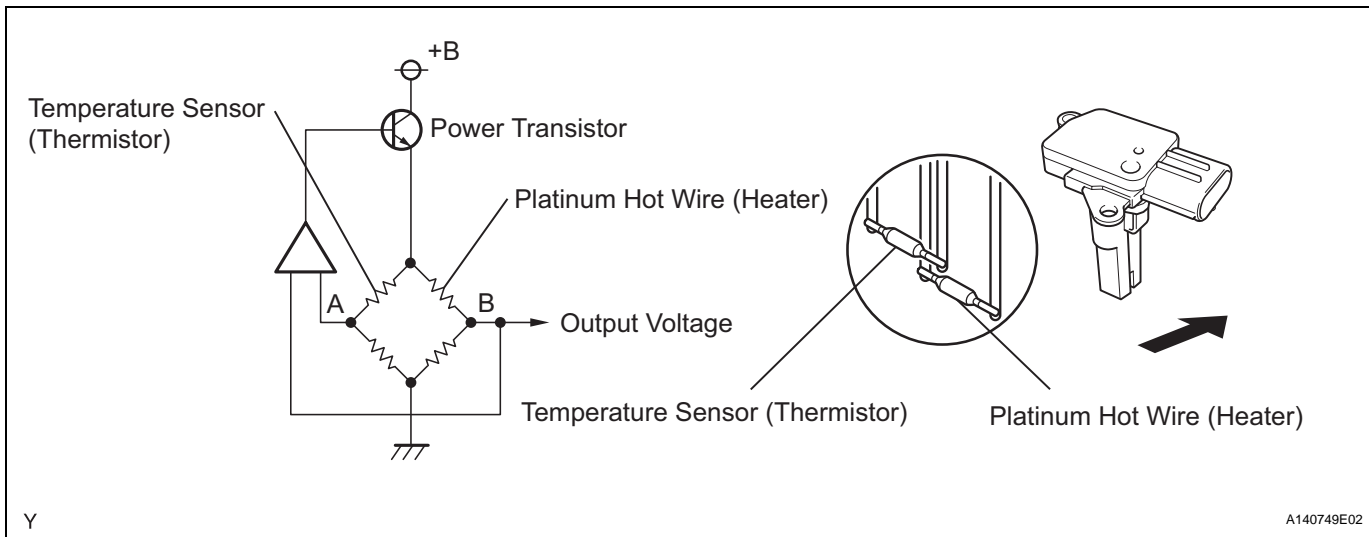

DTC No.	DTC Detection Condition	Trouble Area
P0100	MAF meter voltage less than 0.2 V, or more than 4.9 V for 3 seconds (1 trip detection logic)	<ul style="list-style-type: none"> Open or short in MAF meter circuit MAF meter ECM
P0102	MAF meter voltage less than 0.2 V for 3 seconds (1 trip detection logic)	<ul style="list-style-type: none"> Open or short in MAF meter circuit MAF meter ECM
P0103	MAF meter voltage more than 4.9 V for 3 seconds (1 trip detection logic)	<ul style="list-style-type: none"> Open or short in MAF meter circuit MAF meter ECM

HINT:

When any of these DTCs are set, check the air-flow rate by selecting the following menu items on the intelligent tester: DIAGNOSIS / ENHANCED OBD II / DATA LIST / PRIMARY / MAF.

Mass Air Flow Rate (g/sec.)	Malfunction
Approximately 0.0	<ul style="list-style-type: none"> • Open in Mass Air Flow (MAF) meter power source circuit • Open or short in VG circuit
271.0 or more	<ul style="list-style-type: none"> • Open in E2G circuit

MONITOR DESCRIPTION

If there is a defect in the MAF meter or an open or short circuit, the voltage level deviates from the normal operating range. The ECM interprets this deviation as a malfunction in the MAF meter and sets a DTC.

Example:

When the sensor output voltage remains less than 0.2 V, or more than 4.9 V, for more than 3 seconds, the ECM sets a DTC.

If the malfunction is not repaired successfully, a DTC is set 3 seconds after the engine is next started.

ES**MONITOR STRATEGY**

Related DTCs	P0100: MAF meter range check (Fluctuating) P0102: MAF meter range check (Low voltage) P0103: MAF meter range check (High voltage)
Required Sensors/Components (Main)	MAF meter
Required Sensors/Components (Related)	Crankshaft position sensor
Frequency of Operation	Continuous
Duration	3 seconds
MIL Operation	Immediate: Engine RPM less than 4,000 rpm 2 driving cycles: Engine RPM 4,000 rpm or more
Sequence of Operation	None

TYPICAL ENABLING CONDITIONS

Monitor runs whenever following DTCs not present	None
--	------

TYPICAL MALFUNCTION THRESHOLDS**P0100:**

MAF meter voltage	Less than 0.2 V, or more than 4.9 V
-------------------	-------------------------------------

P0102:

MAF meter voltage	Less than 0.2 V
-------------------	-----------------

P0103:

MAF meter voltage	More than 4.9 V
-------------------	-----------------

COMPONENT OPERATING RANGE

MAF meter voltage	0.4 V to 2.2 V
-------------------	----------------

WIRING DIAGRAM

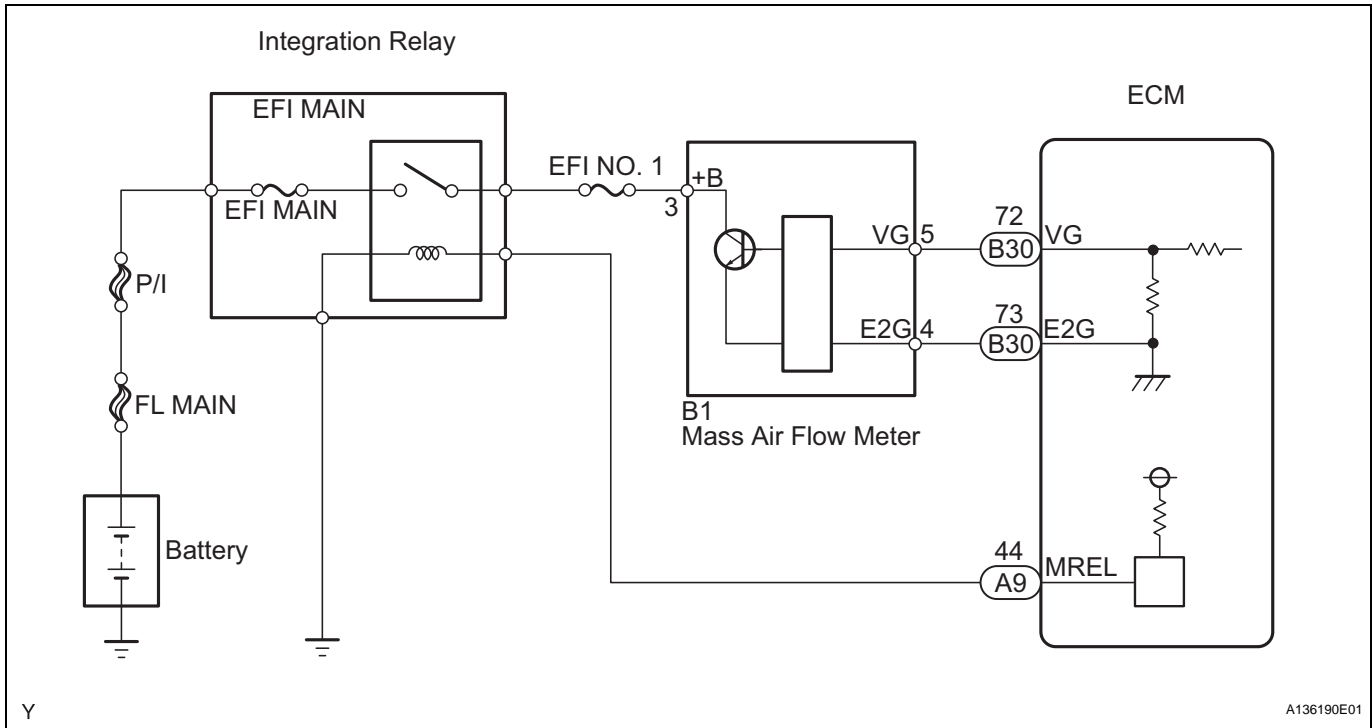

ES

INSPECTION PROCEDURE

HINT:

Read freeze frame data using the intelligent tester. Freeze frame data records the engine condition when malfunctions are detected. When troubleshooting, freeze frame data can help determine if the vehicle was moving or stationary, if the engine was warmed up or not, if the air-fuel ratio was lean or rich, and other data from the time the malfunction occurred.

1 READ VALUE USING INTELLIGENT TESTER (MASS AIR FLOW RATE)

- (a) Connect the intelligent tester to the DLC3.
- (b) Start the engine.
- (c) Turn the tester ON.
- (d) Select the following menu items: DIAGNOSIS / ENHANCED OBD II / DATA LIST / PRIMARY / MAF.
- (e) Read the values displayed on the tester.

Result

Mass Air Flow Rate (g/sec.)	Proceed to
0.0	A
271.0 or more	B
Between 1.0 and 270.0 (*1)	C

HINT:

*1: The value must change when the throttle valve is open or closed with the engine running.

B → **Go to step 6**

C → **CHECK FOR INTERMITTENT PROBLEMS**

A

2 INSPECT MASS AIR FLOW METER (POWER SOURCE VOLTAGE)

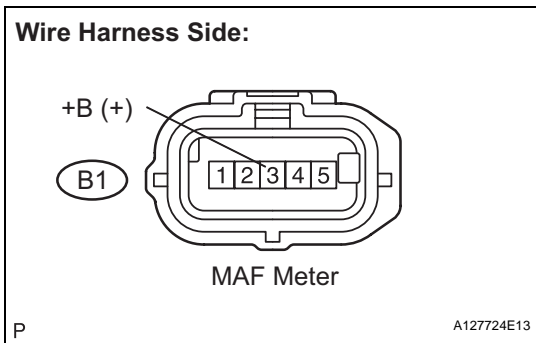

- (a) Disconnect the B1 Mass Air Flow (MAF) meter connector.
- (b) Turn the ignition switch ON.
- (c) Measure the voltage between the terminal of the wire harness side connector and body ground.

Standard voltage

Tester Connection	Specified Condition
B1-3 (+B) - Body ground	9 to 14 V

- (d) Reconnect the MAF meter connector.

NG

Go to step 5

ES

OK

3 INSPECT MASS AIR FLOW METER (VG VOLTAGE)

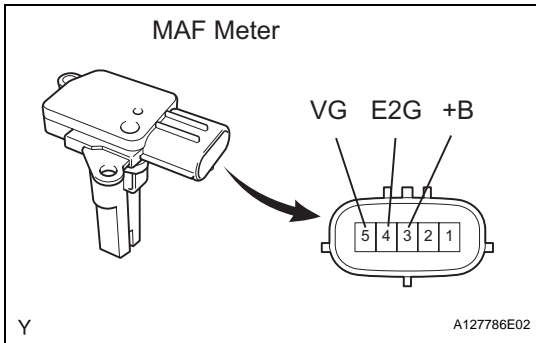

- (a) Output voltage inspection.
 - (1) Apply battery voltage across terminals +B and E2G.
 - (2) Connect the positive (+) tester probe to terminal VG, and negative (-) tester probe to terminal E2G.
 - (3) Measure the voltage.

Standard voltage

Tester Connection	Specified Condition
5 (VG) - 4 (E2G)	0.2 to 4.9 V

NG

REPLACE MASS AIR FLOW METER

OK

4 CHECK WIRE HARNESS (MASS AIR FLOW METER - ECM)

Wire Harness Side:

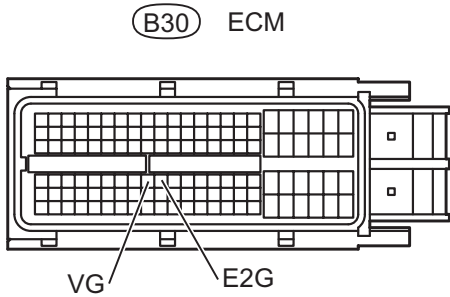
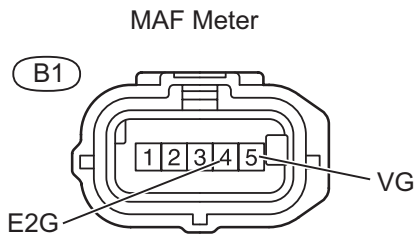

A127959E19

- (a) Disconnect the B1 MAF meter connector.
- (b) Disconnect the B30 ECM connector.
- (c) Measure the resistance.

Standard resistance

Tester Connection	Specified Condition
B1-5 (VG) - B30-72 (VG)	Below 1 Ω
B1-4 (E2G) - B30-73 (E2G)	Below 1 Ω

B1-5 (VG) or B30-72 (VG) - Body ground	10 kΩ or higher
--	-----------------

- (d) Reconnect the MAF meter connector.
- (e) Reconnect the ECM connector.

NG → **REPAIR OR REPLACE HARNESS AND CONNECTOR**

ES

OK

REPLACE ECM

5 CHECK WIRE HARNESS (MASS AIR FLOW METER - INTEGRATION RELAY)

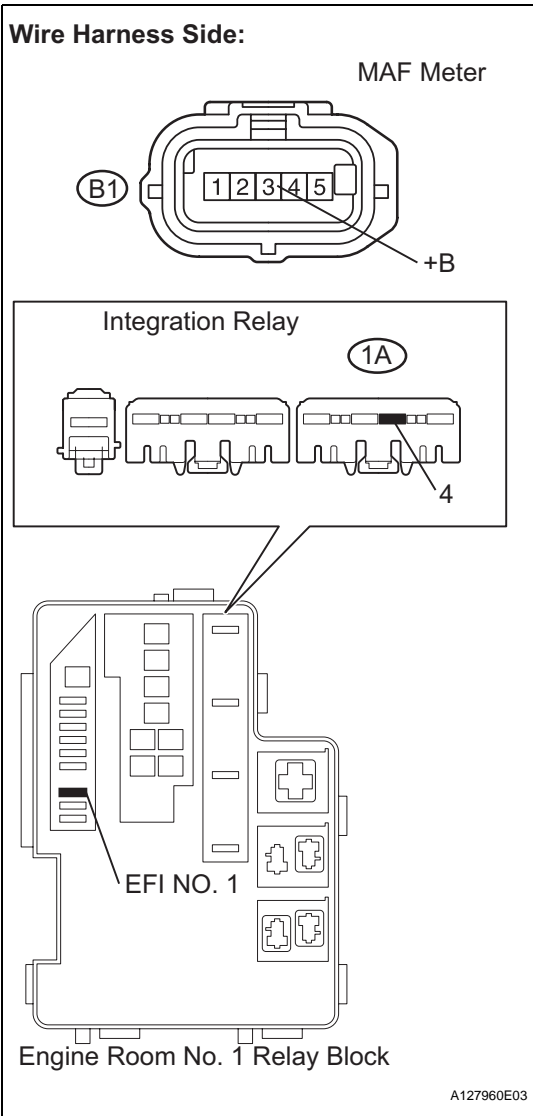

- (a) Check the EFI NO. 1 fuse.
- (b) Disconnect the B1 MAF meter connector.
- (c) Remove the integration relay from the engine room No. 1 relay block.
- (d) Measure the resistance.

Standard resistance

Tester Connection	Specified Condition
B1-3 (+B) - 1A-4	Below 1 Ω
B1-3 (+B) or 1A-4 - Body ground	10 kΩ or higher

- (e) Reconnect the MAF meter connector.
- (f) Reinstall the integration relay.

NG **REPAIR OR REPLACE HARNESS AND CONNECTOR**

ES

OK

CHECK ECM POWER SOURCE CIRCUIT

6 CHECK WIRE HARNESS (SENSOR GROUND)

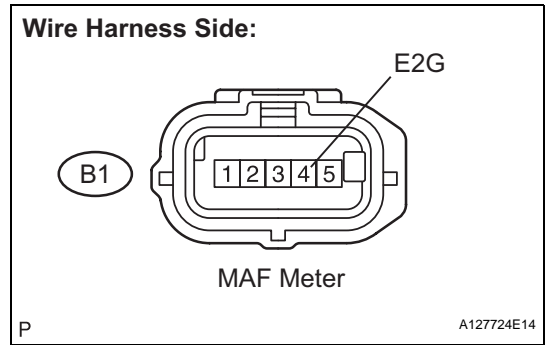

- (a) Disconnect the B1 MAF meter connector.
- (b) Measure the resistance.

Standard resistance

Tester Connection	Specified Condition
B1-4 (E2G) - Body ground	Below 1 Ω

OK → **REPLACE MASS AIR FLOW METER**

ES **NG**

7 CHECK WIRE HARNESS (MASS AIR FLOW METER - ECM)

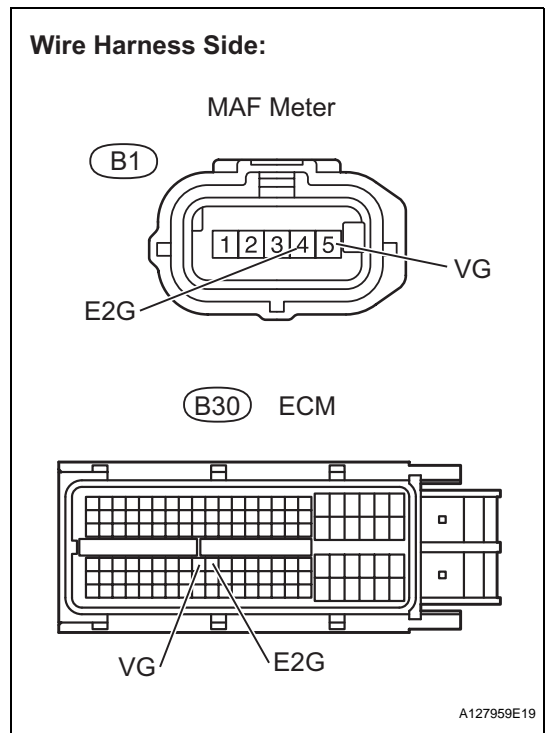

- (a) Disconnect the B1 MAF meter connector.
- (b) Disconnect the B30 ECM connector.
- (c) Measure the resistance.

Standard resistance

Tester Connection	Specified Condition
B1-5 (VG) - B30-72 (VG)	Below 1 Ω
B1-4 (E2G) - B30-73 (E2G)	Below 1 Ω
B1-5 (VG) or B30-72 (VG) - Body ground	10 kΩ or higher

- (d) Reconnect the MAF meter connector.
- (e) Reconnect the ECM connector.

NG → **REPAIR OR REPLACE HARNESS AND CONNECTOR**

OK

REPLACE ECM