

GENERATOR COMPONENTS

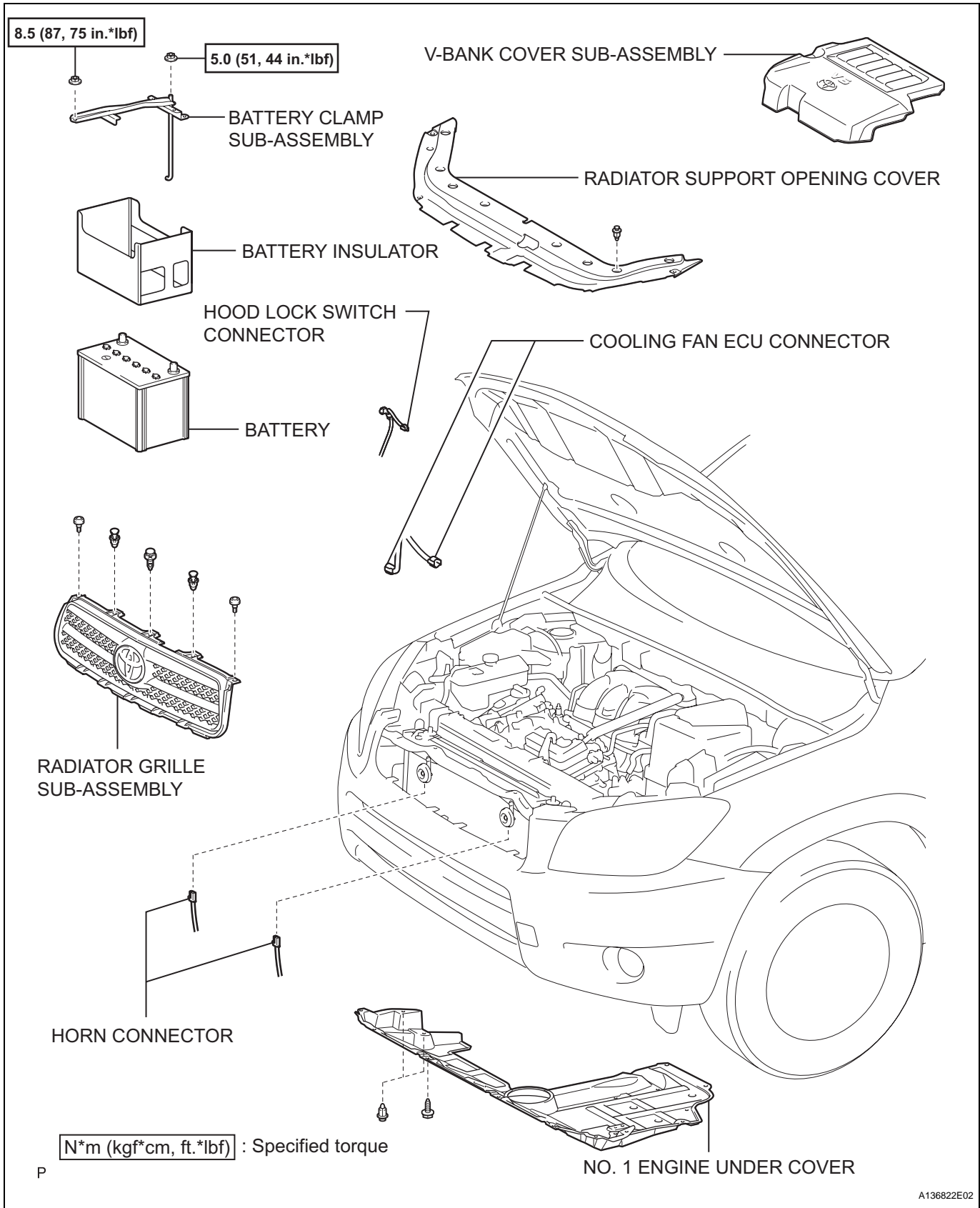

CH

P

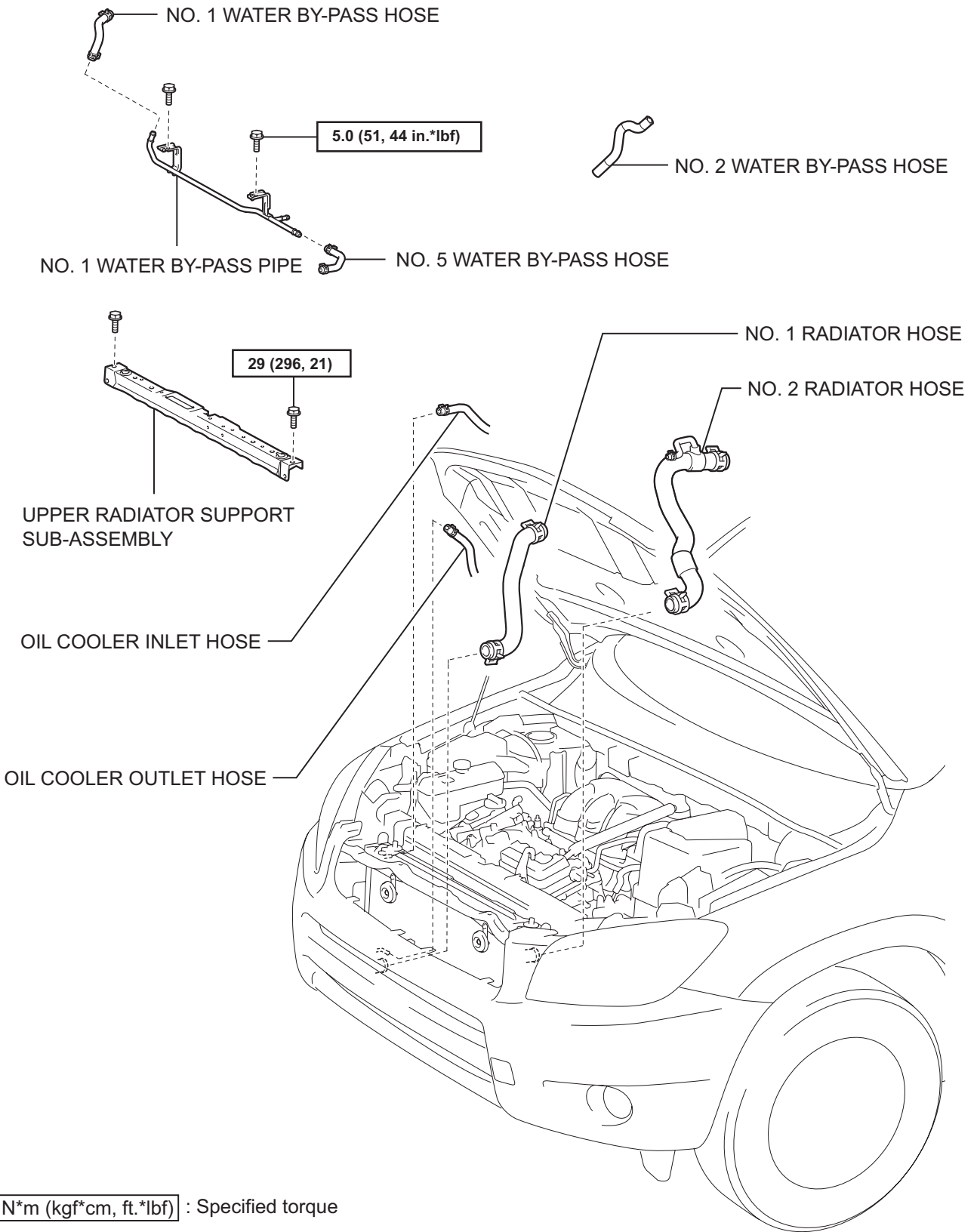

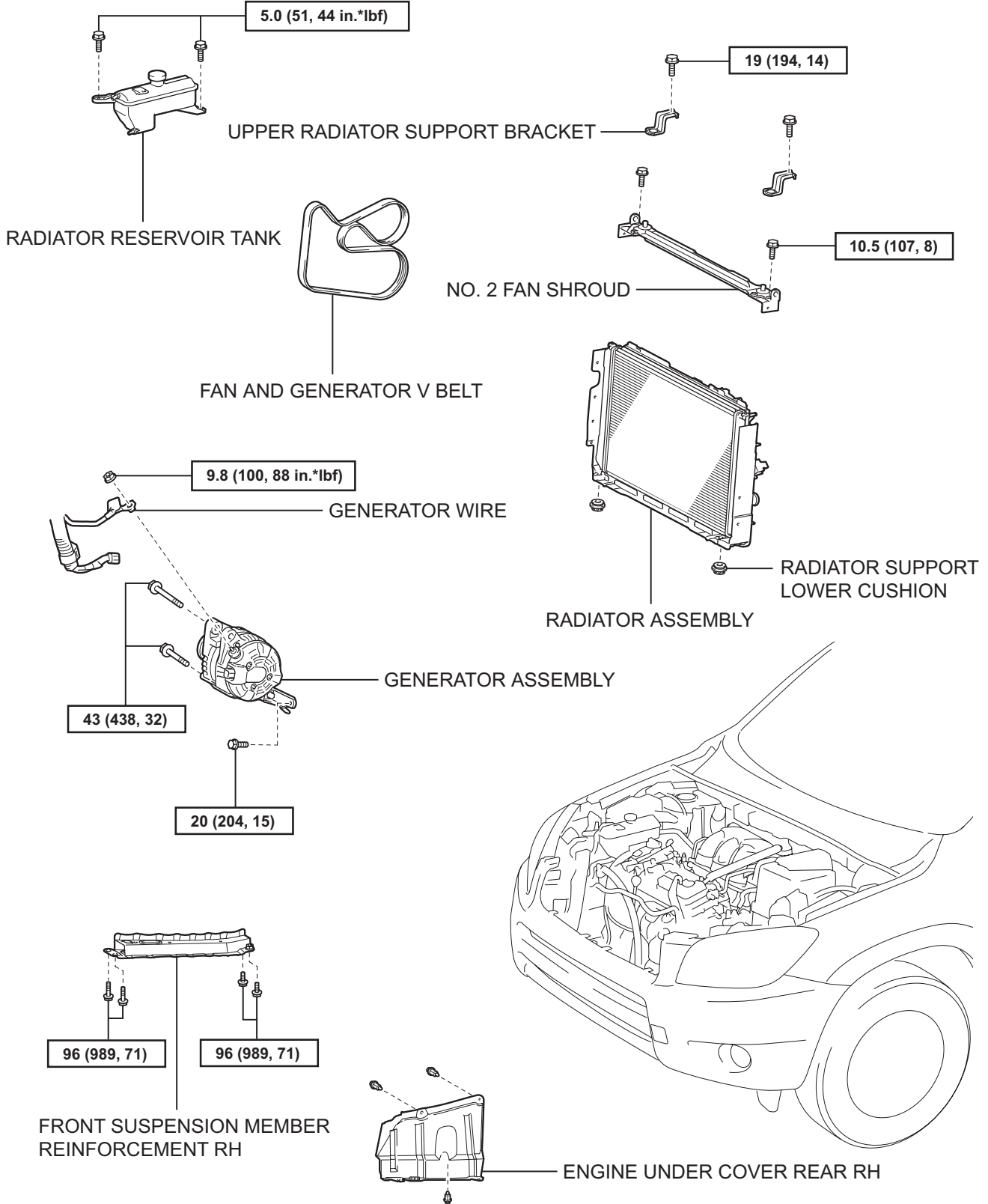

N*m (kgf*cm, ft.*lbf) : Specified torque

