

REMOVAL

1. REMOVE FUEL TANK ASSEMBLY

- (a) Remove the fuel tank (see page [FU-39](#)).

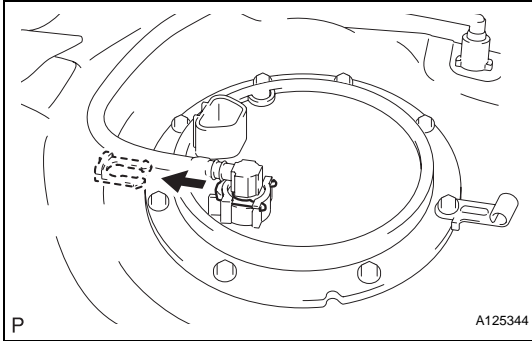

2. REMOVE FUEL TANK MAIN TUBE SUB-ASSEMBLY

- (a) Remove the joint clip and fuel tank main tube.

CAUTION:

- Before removing the tube joint clip, check for foreign matter around the clip. Clean if necessary.
- Keep the O-ring free of foreign matter, as it becomes contaminated easily.
- Do not use any tools in this procedure.
- Do not forcefully bend or twist the tube.
- Put the tube in a plastic bag to prevent damage and contamination.
- If the fuel suction plate and tube are stuck together, pinch the tube and turn it carefully to disconnect it.
- Be careful not to damage the clip. If the clip is damaged, replace it.

3. REMOVE FUEL TANK VENT TUBE SET PLATE

- (a) Remove the 8 bolts and set plate.

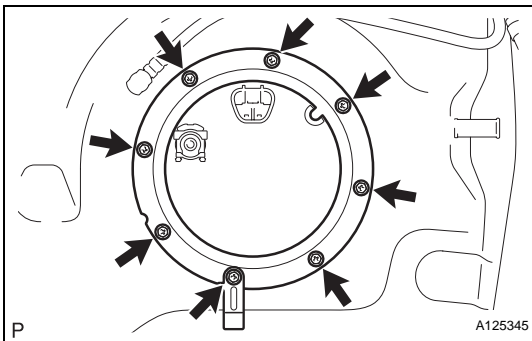

4. REMOVE FUEL SUCTION WITH PUMP ASSEMBLY

- (a) Disconnect the fuel hose and remove the fuel pump from the fuel tank.

NOTICE:

Do not damage the fuel pump.

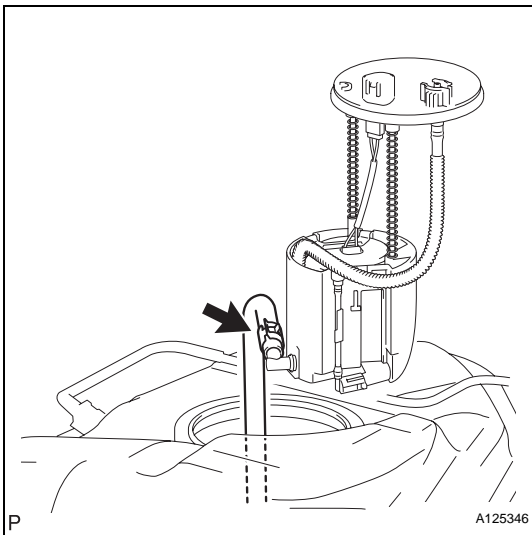

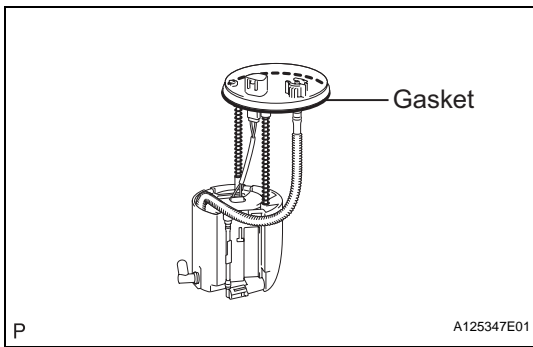

(b) Remove the gasket from the fuel pump.

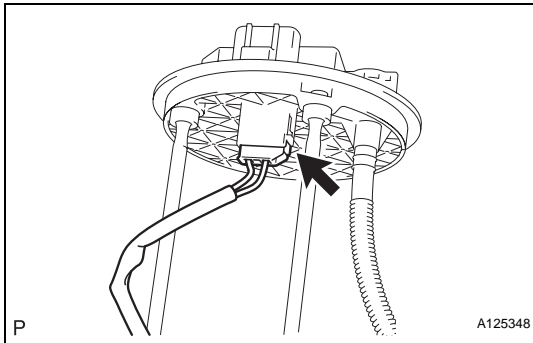

5. REMOVE FUEL SUB-TANK ASSEMBLY

(a) Disconnect the wire harness.

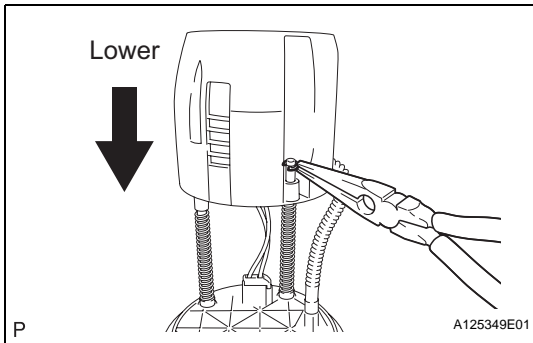

(b) Using needle nose pliers, remove the E-ring.
HINT:
Slightly lower the sub-tank to remove the E-ring.

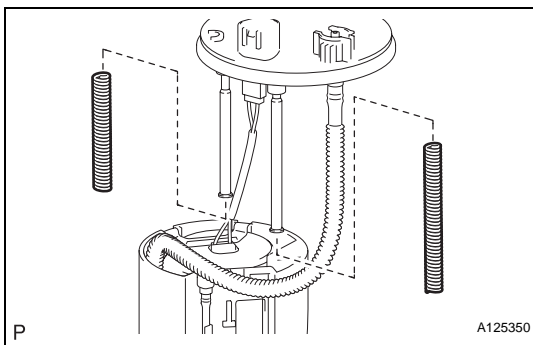

(c) Remove the 2 springs from the 2 shaft.

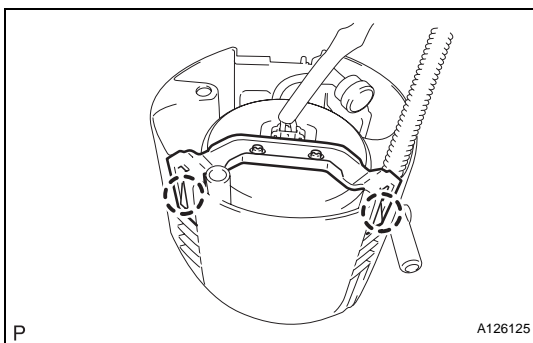

(d) Detach the 2 claws and remove the sub-tank.

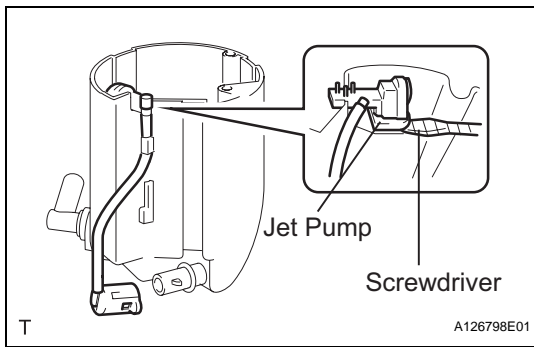

- (e) Disengage the claw of the jet pump nozzle.
- (f) Using a screwdriver with the tip taped, remove the jet pump.

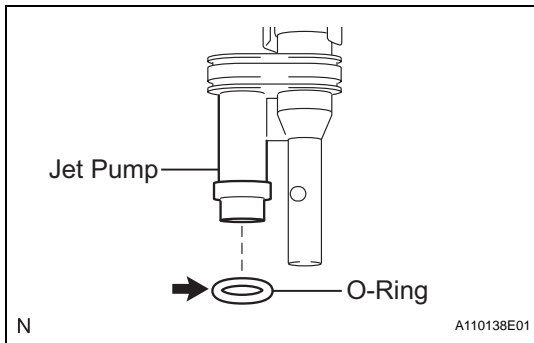

- (g) Remove the O-ring from the jet pump.

FU

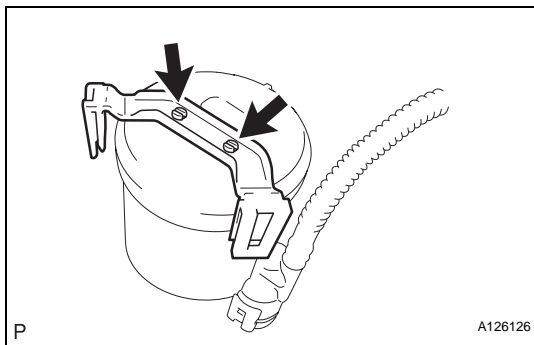

6. REMOVE BRACKET

- (a) Using a screwdriver, detach the 2 claws and remove the bracket.
HINT:
Tape the screwdriver tip before use.

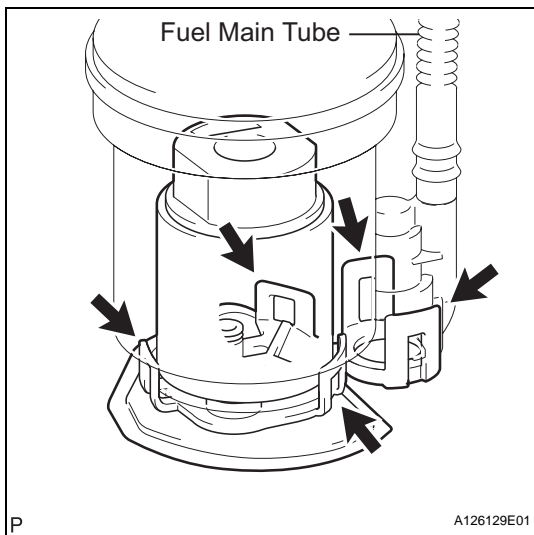

7. REMOVE FUEL PUMP ASSEMBLY

- (a) Detach the 5 claws on the filter and remove the fuel pump from the fuel filter.
HINT:
When removing the claw, do not disconnect the fuel main tube.