

TIMING CHAIN

COMPONENTS

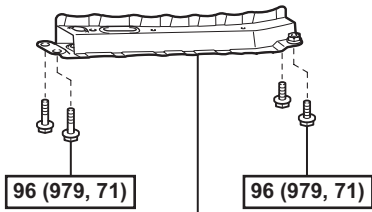

FRONT SUSPENSION MEMBER REINFORCEMENT RH

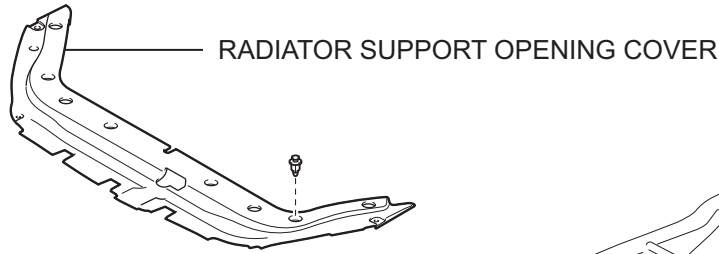
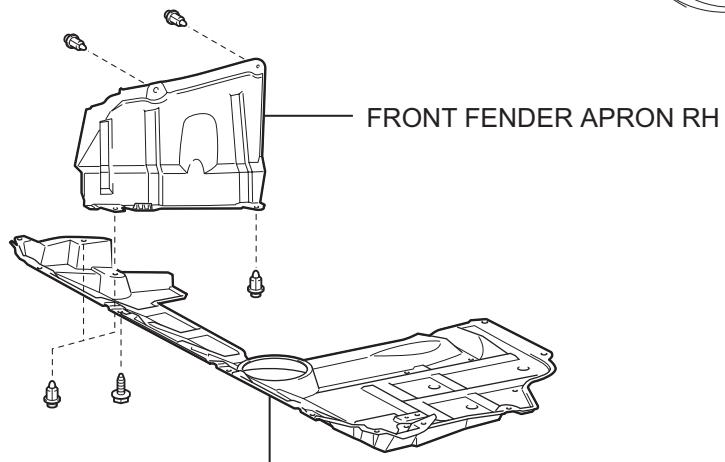

N*m (kgf*cm, ft.*lbf) : Specified torque

EM

EM

5.0 (51, 44 in.*lbf)

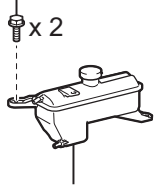

RADIATOR RESERVOIR

FAN AND GENERATOR V BELT

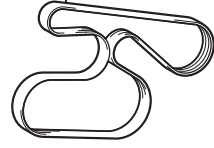

7.0 (71, 62 in.*lbf)

x 2

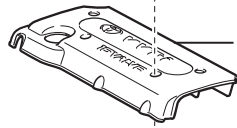

NO. 1 ENGINE COVER

60 (612, 44)

x 2



IDLER PULLEY

95 (969, 70)

x 4

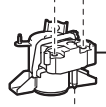

ENGINE MOUNTING INSULATOR RH

52 (530, 38)



8.4 (86, 74 in.*lbf)



HEATED OXYGEN SENSOR CONNECTOR

9.8 (100, 7)

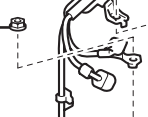

52 (530, 38)

21 (215, 15)

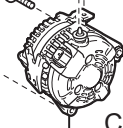

COMPRESSION SPRING

GENERATOR ASSEMBLY

GASKET



43 (438, 32)

GASKET



43 (438, 32)

43 (438, 32)

FRONT EXHAUST PIPE

N*m (kgf*cm, ft.*lbf) : Specified torque

● Non-reusable part

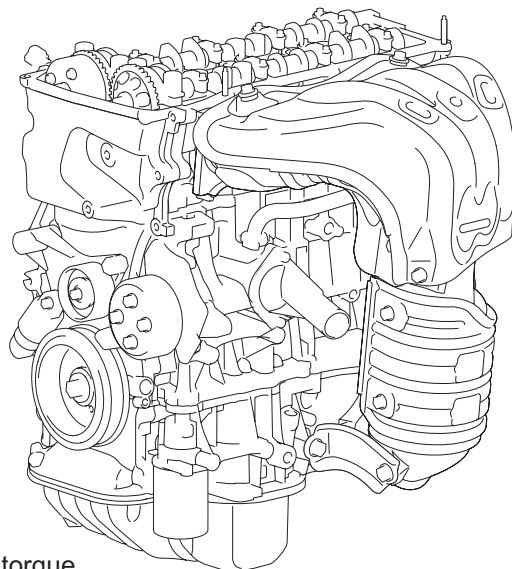
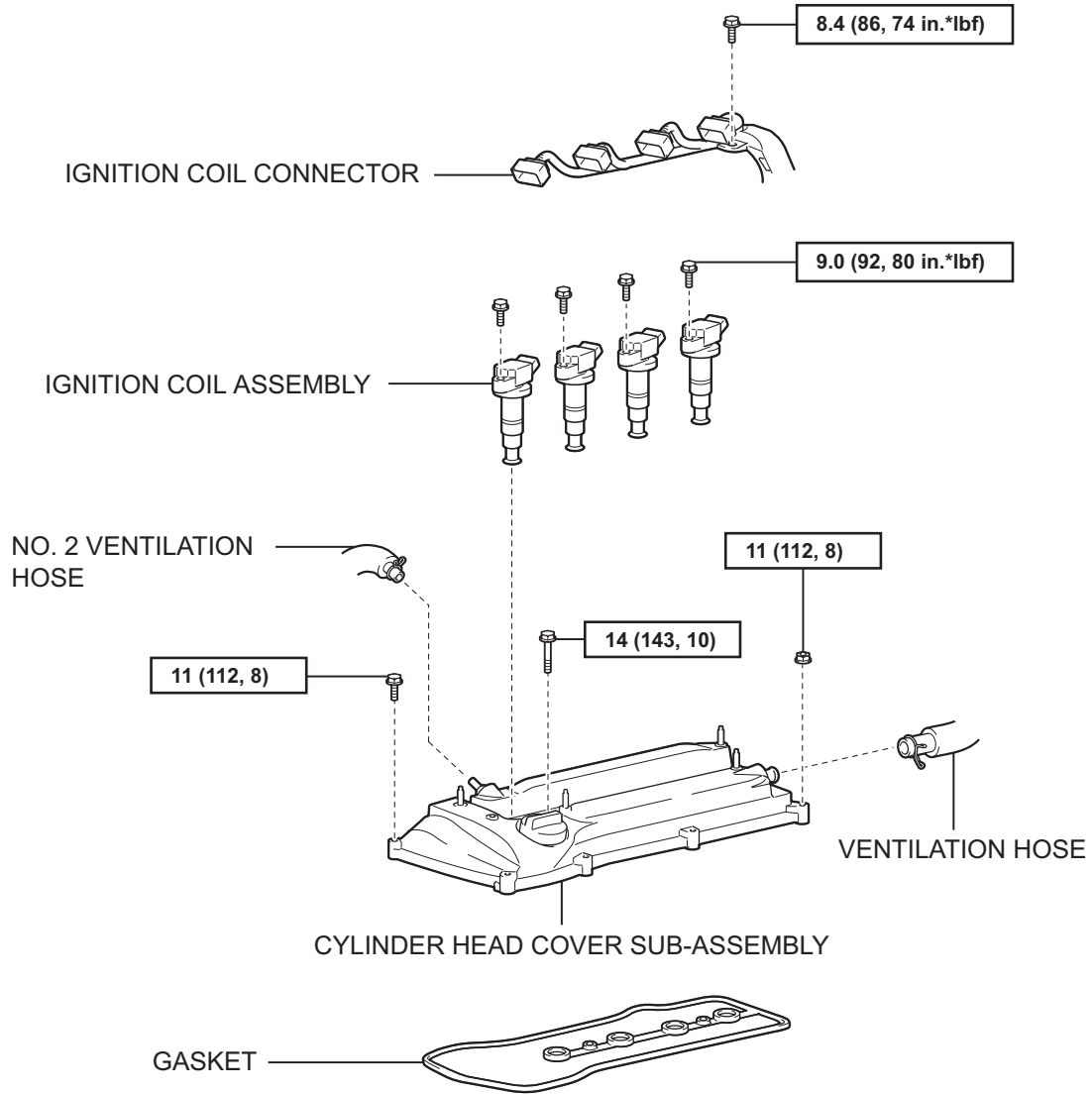

N*m (kgf*cm, ft.*lbf) : Specified torque

EM

EM

NO. 1 CHAIN TENSIONER ASSEMBLY

GASKET

9.0 (92, 80 in.*lbf)

11 (112, 8)

ENGINE MOUNTING BRACKET RH

11 (112, 8)

55 (561, 41)

55 (561,41)

55 (561,41)

59.5 (607, 44)

59.5 (607, 44)

9.0 (92, 80 in.*lbf)

21.5 (219, 16)

TIMING CHAIN COVER SUB-ASSEMBLY

V-RIBBED BELT TENSIONER ASSEMBLY

180 (1,835, 133)

CRANKSHAFT PULLEY

25 (255, 18)

TIMING CHAIN COVER OIL SEAL

CRANKSHAFT POSITION SENSOR

9.0 (92, 80 in.*lbf)

9.0 (92, 80 in.*lbf)

N*m (kgf*cm, ft.*lbf) : Specified torque

● Non-reusable part

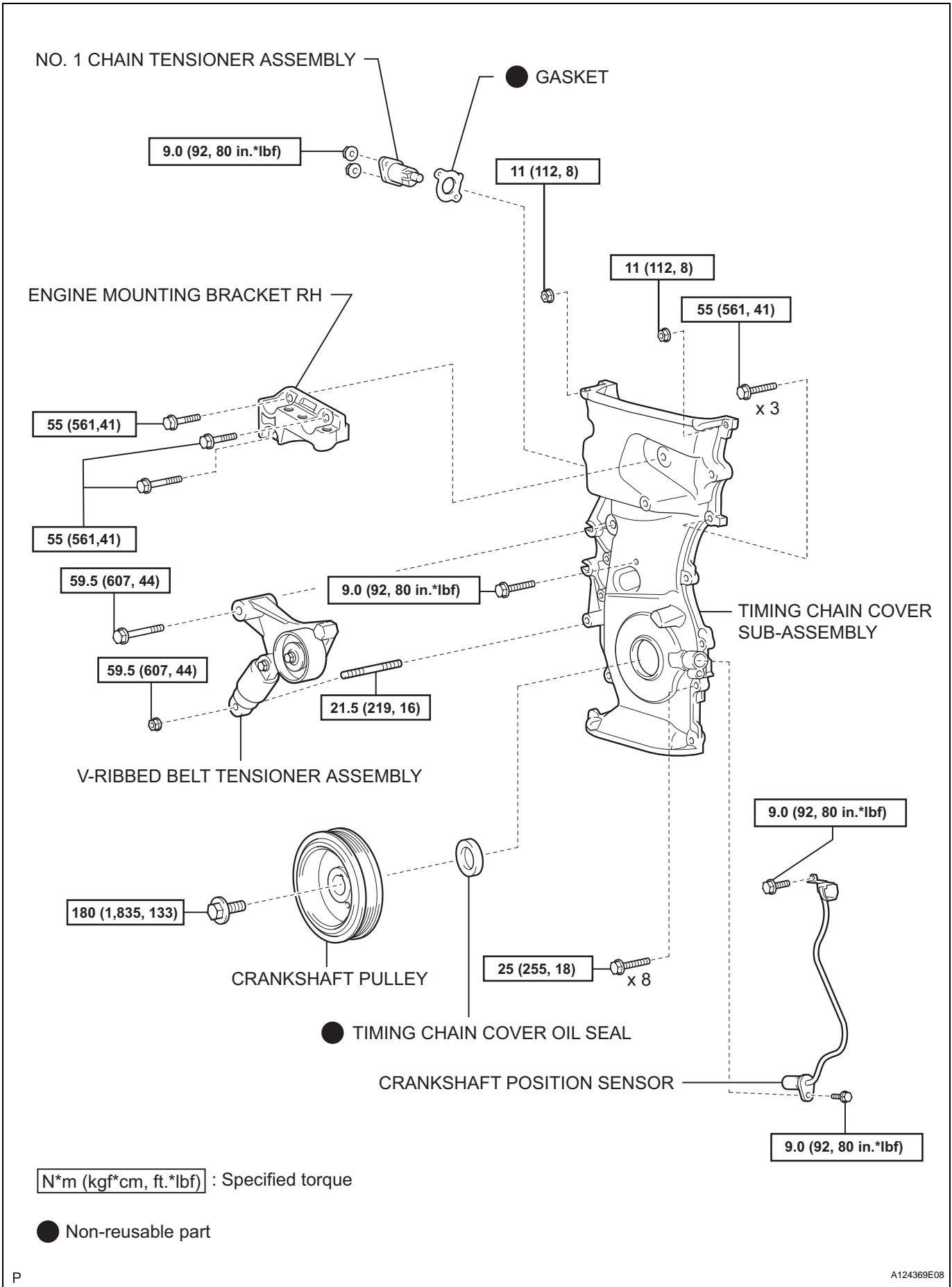

EM

