

INSTALLATION

1. INSTALL VENTILATION VALVE SUB-ASSEMBLY

- (a) Apply adhesive to 2 or 3 threads of the ventilation valve.

Adhesive:

Toyota genuine adhesive 1324, three bond 1324 or equivalent

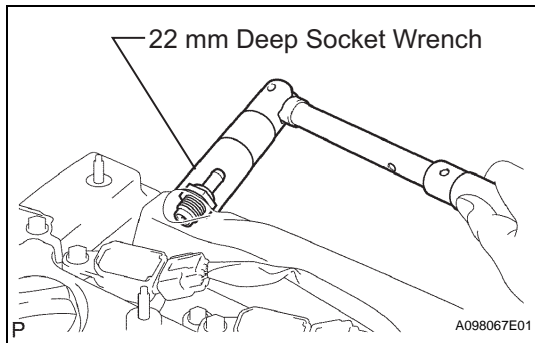

- (b) Using a 22 mm deep socket wrench, install the ventilation valve.

Torque: 19 N*m (194 kgf*cm, 14 ft.*lbf)

- (c) Connect the ventilation hose.

2. INSTALL NO. 1 ENGINE COVER (See page [EM-43](#))

3. CHECK FOR ENGINE OIL LEAKS