

RADIATOR COMPONENTS

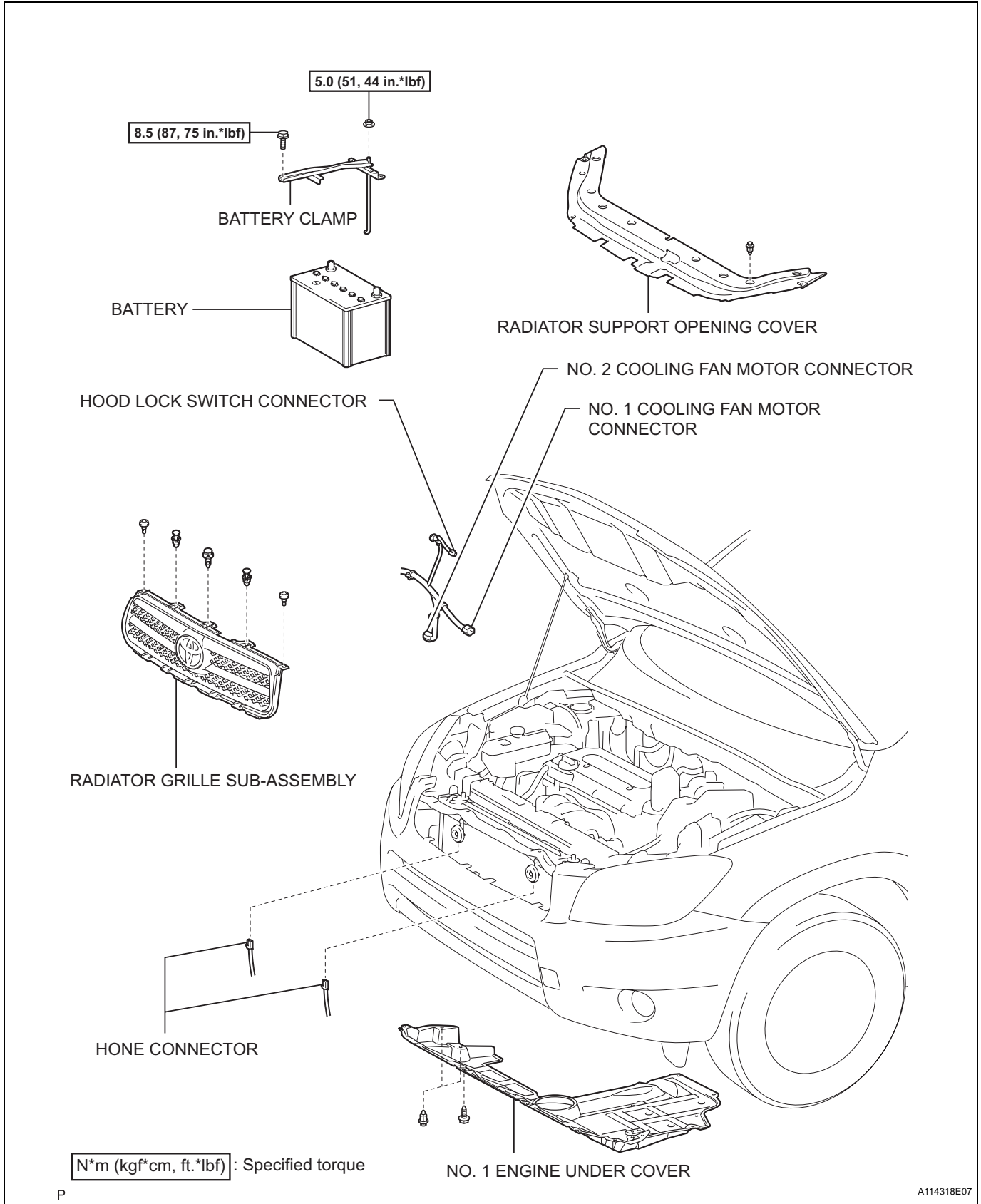

CO

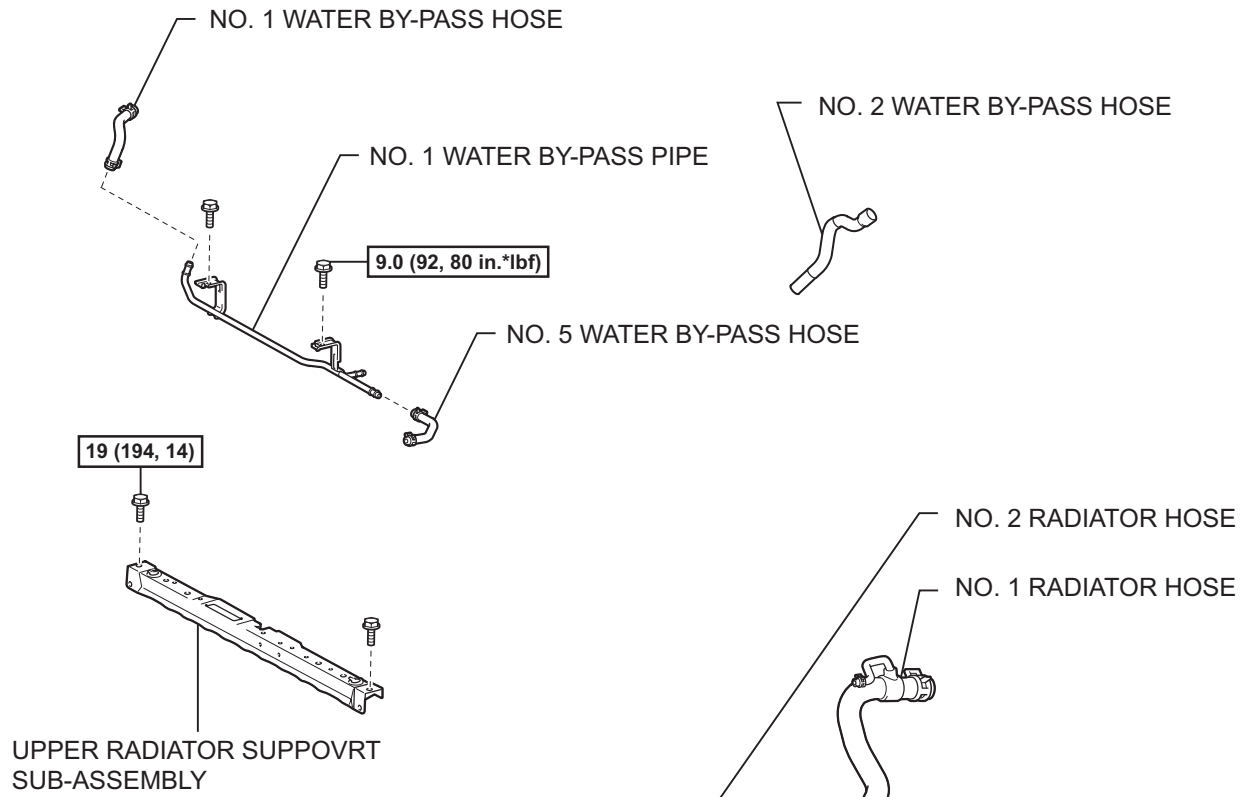

CO

N*m (kgf*cm, ft.*lbf) : Specified torque

P

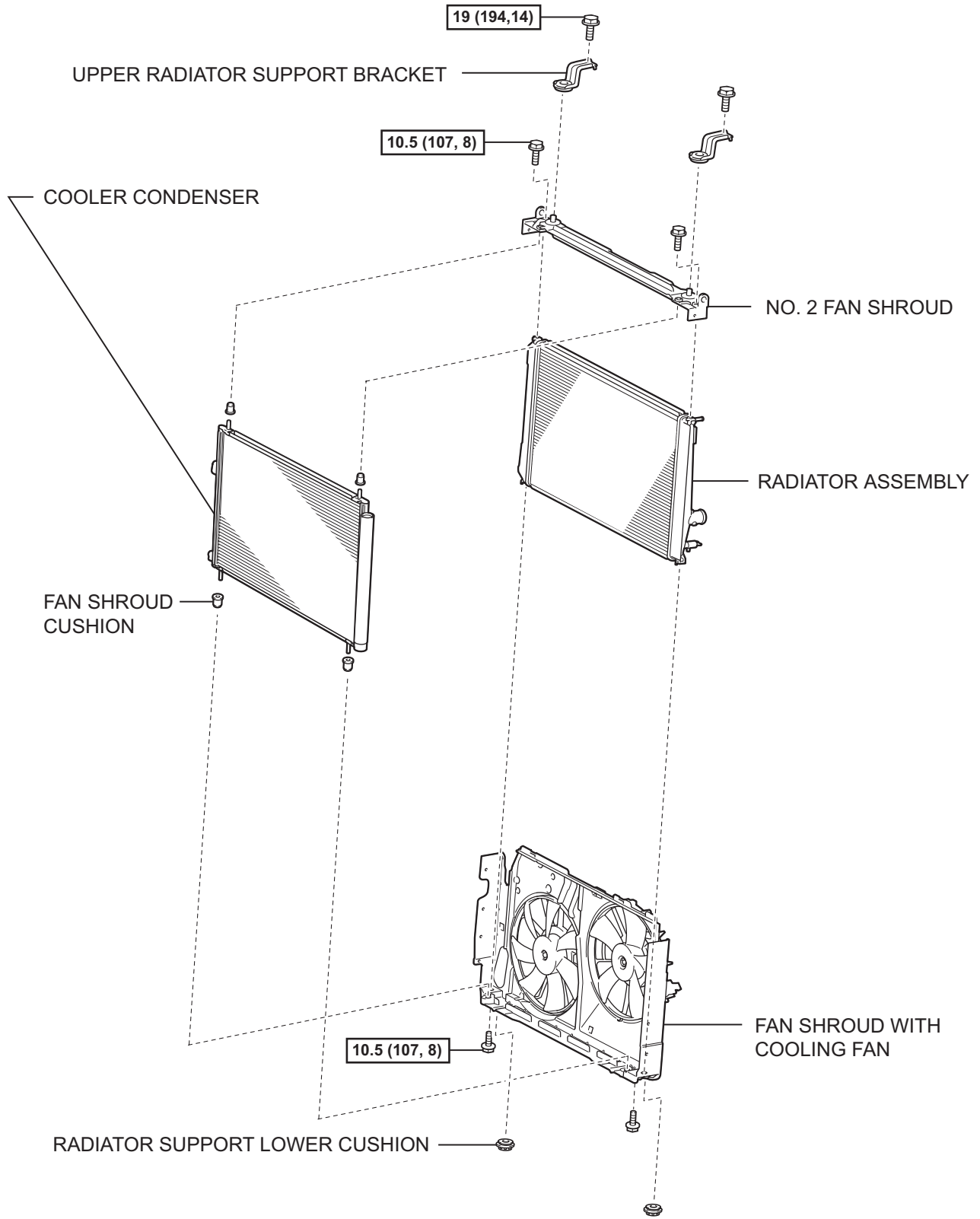

N*m (kgf*cm, ft.*lbf) : Specified torque

CO

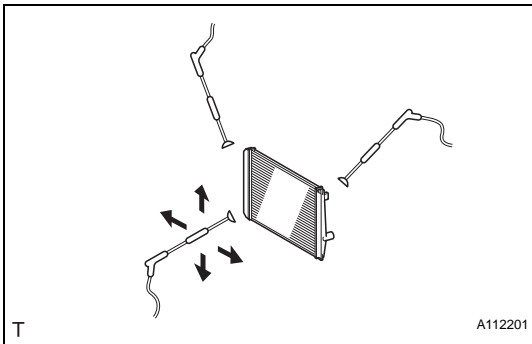
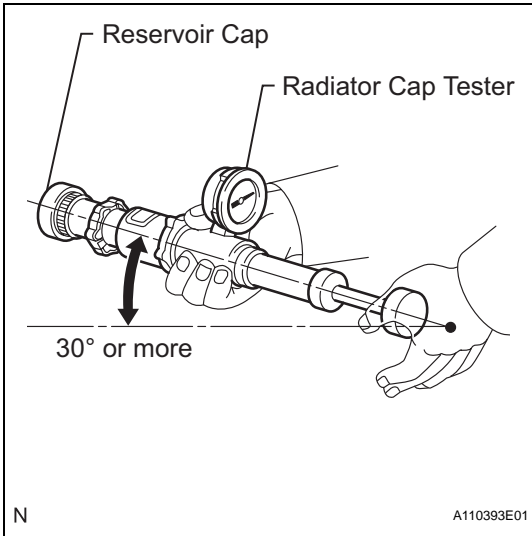
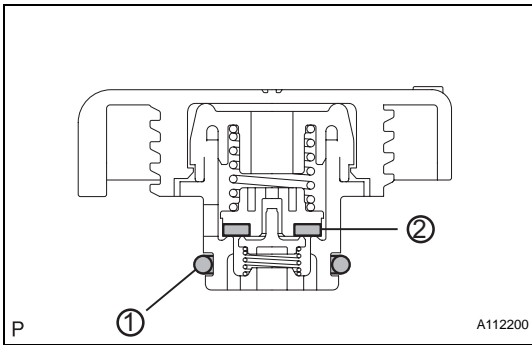

ON-VEHICLE INSPECTION

1. CHECK RADIATOR RESERVOIR CAP SUB-ASSEMBLY

- (a) Measure the valve opening pressure.
 - (1) If there are water stains or foreign matter on O-ring 1, clean it with water and finger scouring.
 - (2) Check that O-ring 1 is not deformed, cracked or swollen.
 - (3) Apply engine coolant to O-ring 1 and rubber packing 2 before using a radiator cap tester.
 - (4) When using the cap tester, tilt it more than 30 degrees.
 - (5) Pump the cap tester several times, and check the maximum pressure*.

Pump speed:

1 pump per second

*: Even if the cap cannot maintain the maximum pressure, it is not a defect.

Judgment criterion

Item	Specified Condition
Standard value (for brand-new cap)	93.3 to 122.7 kPa (0.95 to 1.25 kgf/cm ² , 13.5 to 17.8 psi)
Minimum standard value (after using cap)	78.5 kPa (0.8 kgf/cm ² , 11.4 psi)

If the maximum pressure is less than the minimum standard value, replace the radiator reservoir cap sub-assembly.

ON-VEHICLE CLEANING

1. INSPECT RADIATOR ASSEMBLY

- (a) Check that the radiator and condenser are not blocked with leaves, dirt, or insects. Clean the hose connections. If the fins are blocked, wash them with water or a steam cleaner.

NOTICE:

- If the distance between the steam cleaner and core is too close, the fins may be damaged.
- Keep the following injection distance.

Standard injection distance

Injection Pressure	Specified Condition
2,942 to 4,903 kPa (30 to 50 kgf/cm ² , 427 to 711 psi)	300 mm (11.81 in.)
4,903 to 7,845 kPa (50 to 80 kgf/cm ² , 711 to 1,138 psi)	500 mm (19.69 in.)

- If the fins are bent, straighten them with a screwdriver or pliers.
- Never apply water directly onto the electronic components.

- (b) Dry the fins with compressed air.

CO