

METER

■ COMBINATION METER

1. General

The combination meter of '04 Prius has the following features.

- The combination meter is available as a digital display type. It is located at the upper of the instrument panel to improve its visibility.
- A reflective virtual image display meter, which uses a VFD (Vacuum Fluorescent Display), a mirror, and a smoke acrylic plate to reflect the images of the speedometer, ODO/TRIP meter, fuel gauge, shift position indicator light, and READY indicator light, has been adopted to improve visibility.
- A meter ECU and buzzer are enclosed in the combination meter. This ECU maintains communication with other ECUs through the BEAN. In addition, this ECU maintains communication with other ECUs or devices comprising the CAN and AVC-LAN networks, via the gateway ECU.
- A “READY” light that informs the driver that the vehicle is ready to be driven is used.
- The contents of the warning issued with the illumination of the master warning light have been changed.
- The output control warning light has been discontinued.
- A low ambient temperature indicator light, which illuminates when the ambient temperature is low (ambient temperature of 3°C [37.4°F] or less) to alert the driver, has been adopted.
- The following indicator lights have been provided for the air conditioning system: A/C AUTO, RECIRCULATION, Front DEF, and Rear DEF.
- Two inclination sensors are used in the combination meter to detect the inclination (longitudinal and latitudinal) of the vehicle.
- Oil replacement reminder light has been established in the combination meter, which will light or flash to remind the driver to change the engine oil depending on the vehicle driving distance.
- A fuel lid mark uses to point the side of the vehicle where the fuel lid is located.

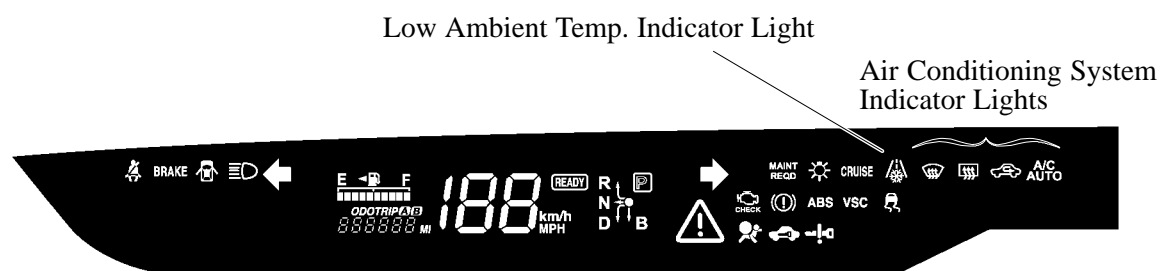

2. System Diagram

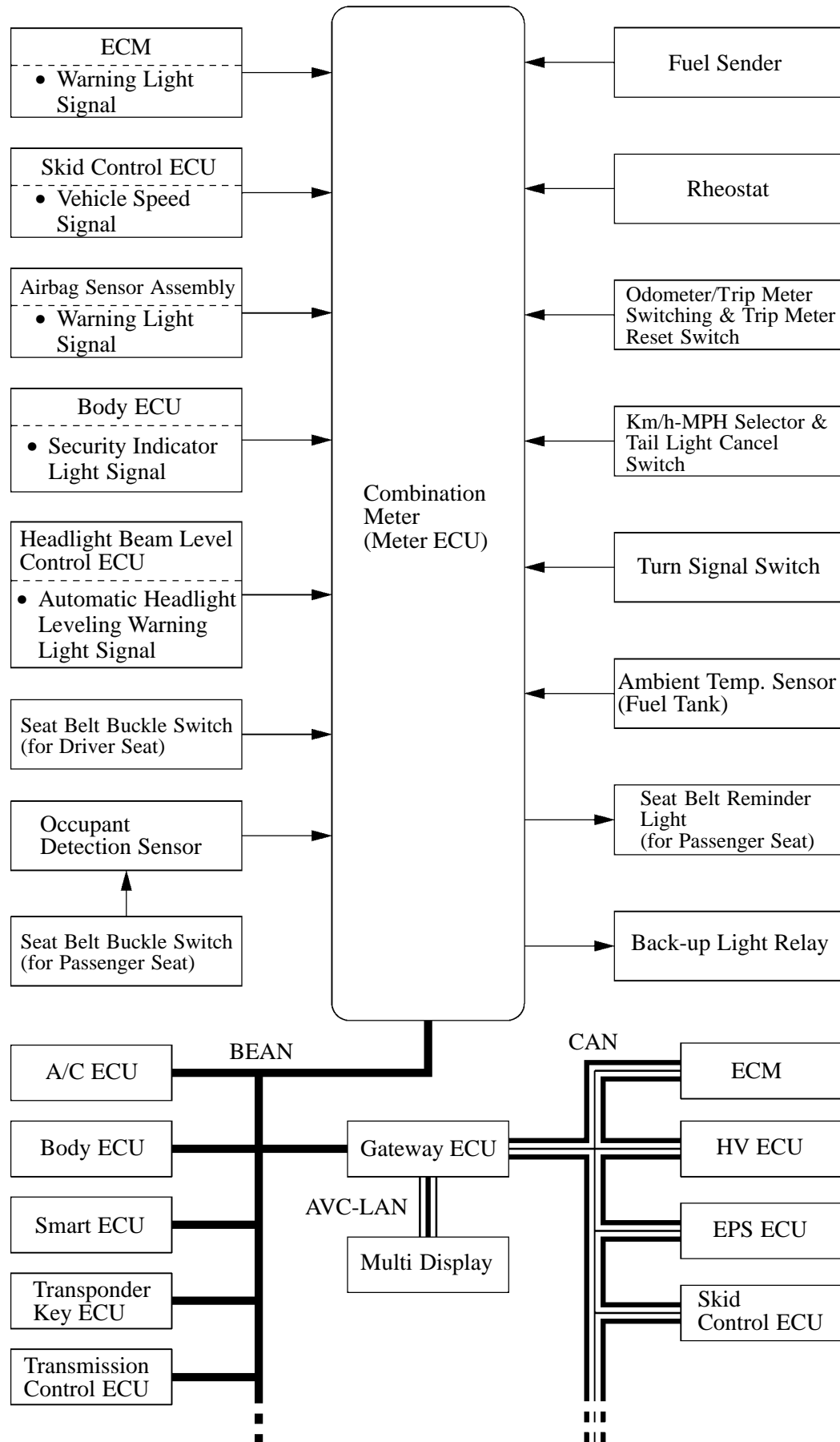

► MPX Communication ◀

Protocol	ECU	Signals Exchanged with Combination Meter (Meter ECU)
BEAN	A/C ECU	<ul style="list-style-type: none"> • Transmits ambient Temp. signal • Transmits an indicator light (A/C AUTO, RECIRCULATION, Front DEF, and Rear DEF) illumination request signal. • Receives vehicle speed signal
	Body ECU	<ul style="list-style-type: none"> • Transmits a meter illumination light dim request signal. • Transmits driver's door courtesy switch signal • Transmits all door courtesy switch signal • Transmits a headlight illumination signal • Transmits a tail light illumination signal. • Transmits front fog light illumination signal • Receives vehicle speed signal
	Smart ECU	<ul style="list-style-type: none"> • Transmits smart entry system warning light illumination request signal • Transmits a buzzer sounding request signal. • Receives vehicle speed signal
	Transmission Control ECU	<ul style="list-style-type: none"> • Transmits a master warning light (Transmission control ECU malfunction) illumination request signal. • Transmits shift position (N, P) signal
	Transponder Key ECU	<ul style="list-style-type: none"> • Transmits a master warning light (shift warning) illumination signal. • Transmits a buzzer sounding request signal. • Receives vehicle speed signal
CAN	HV ECU	<ul style="list-style-type: none"> • Transmits a shift position signal (P,R,N,D,B). (for shift position indicator light) • Transmits a READY indicator light illumination or blinking signal. • Transmits a master warning light (HV system, main battery, NDB warning, high water Temp., CHARGE) illumination request signal • Transmits a cruise indicator light illumination request signal
	ECM	<ul style="list-style-type: none"> • Transmits an engine speed signal (for calculating trip information). • Transmits an engine coolant Temp. signal (for master warning light [engine coolant Temp. warning]) • Transmits a fuel injection volume signal (for calculating trip information) • Transmits a master warning light (oil pressure) illumination signal • Receives fuel tank volume signal
	Skid Control ECU	<ul style="list-style-type: none"> • Transmits a warning light (ABS, VSC, BRAKE, ECB) illumination or blinking signal. • Transmits a slip indicator light illumination or blinking signal.
	EPS ECU	<ul style="list-style-type: none"> • Transmits a master warning light (EPS) illumination request signal
AVC-LAN	Multi Display	<ul style="list-style-type: none"> • Transmits a trip information operation signal • Receives warning (fuel volume, headlight leveling, EPS) display signal • Receives trip information display signal

3. Reflective Virtual Image Display Meter

- A reflective virtual image display meter, which uses a VFD, a mirror, and a smoke acrylic plate to reflect the images of the speedometer, ODO/TRIP meter, fuel gauge, shift position indicator light, and READY indicator light, has been adopted to improve visibility.
- In this meter, the image on the VFD is reflected by the mirror and the smoke acrylic plate, and appears as a virtual image to the driver. This type realizes excellent visibility because it is less susceptible to external light.

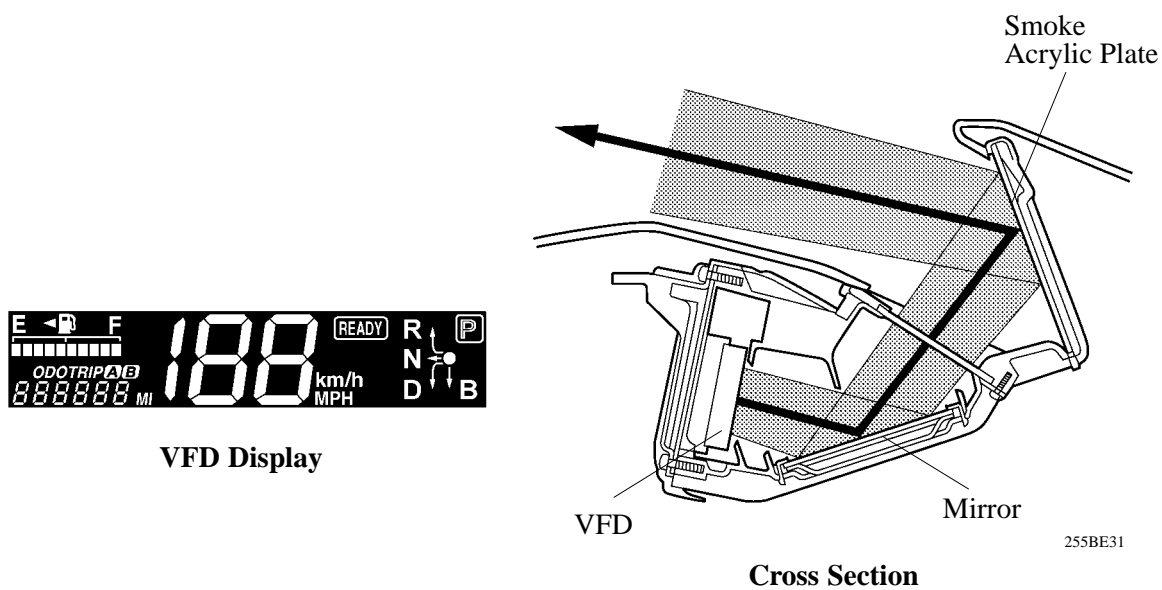

4. Indicator and Warning Light

Ready Light

When the shift position is P and the brake pedal is depressed, turning the power switch to READY causes the “READY” light to flash and enables the vehicle to be driven. Then, this indicator illuminates and the buzzer sounds simultaneously.

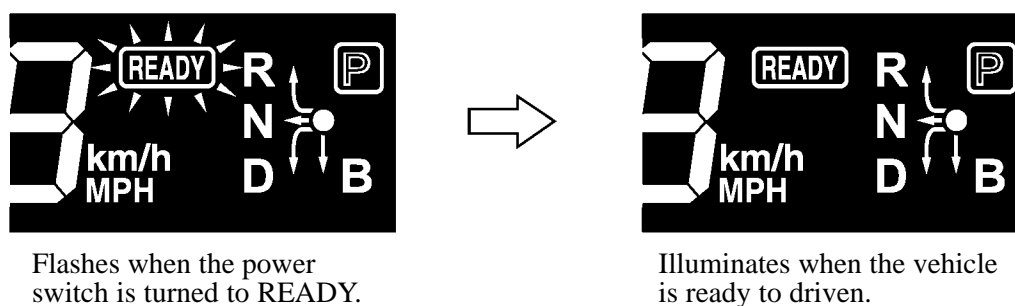

Service Tip

If the indicator does not illuminate, the vehicle cannot be driven because one of the driving prohibition conditions listed below applies.

- Service plug discontinued.
- Hybrid system abnormality.
- Driving prohibition condition due to overload on MG1, MG2 or inverter.
- Inverter unit cover is left open.
- HV ECU has detected a collision.

Master Warning Light

If any of the situations indicated below occur, the meter ECU will illuminate the master warning light and sound the buzzer. At the same time, a warning will appear on the multi display.

Master Warning Light	Outline
Hybrid System Abnormal	When the abnormality occurs in the hybrid system.
HV Battery Warning	When the HV battery voltage drops.
N, D and B Range Warning	<ul style="list-style-type: none"> The READY light is illuminated, the shift position is in the N position, and the HV battery is discharged. The READY light is illuminated, the shift position is in the N, B or D position, and the driver's door is open.
High Engine Coolant Temperature Warning	<ul style="list-style-type: none"> When the engine coolant temperature is above specified value. When the inverter coolant temperature is above specified value.
Discharge Warning	When there is a malfunction in the 12 V charging system (converter assembly).
Oil Pressure Warning	When the engine oil pressure is low.
EPS Warning	When there is a malfunction in the EPS system.
Shift Position Warning	When the hybrid system is OFF, the shift position is in a position other than P, and the driver's door is opened.
Transmission Control ECU Warning	When there is a malfunction in the transmission control ECU.
Automatic Headlight Leveling System Warning	When there is a malfunction in the automatic headlight leveling system.

Low Ambient Temperature Indicator Light

- If the ambient temperature drops, and may create a situation such as a frozen road surface that requires the driver to pay attention, the meter ECU illuminates the low ambient temperature indicator light to alert the driver.
- When the power switch is turned ON, the meter ECU will turn ON the low ambient temperature indicator light for 3 seconds in order to check the bulb.
- The meter ECU uses the ambient temperature sensor signal provided by the air conditioning system in order to determine the ambient temperature. If the meter ECU has determined that the ambient temperature is approximately 3°C (37.4°F) or less, it causes the indicator light to blink for 3 seconds and illuminate thereafter. If the ambient temperature rises to 5°C (41°F) or above, the meter ECU will turn OFF the indicator light.

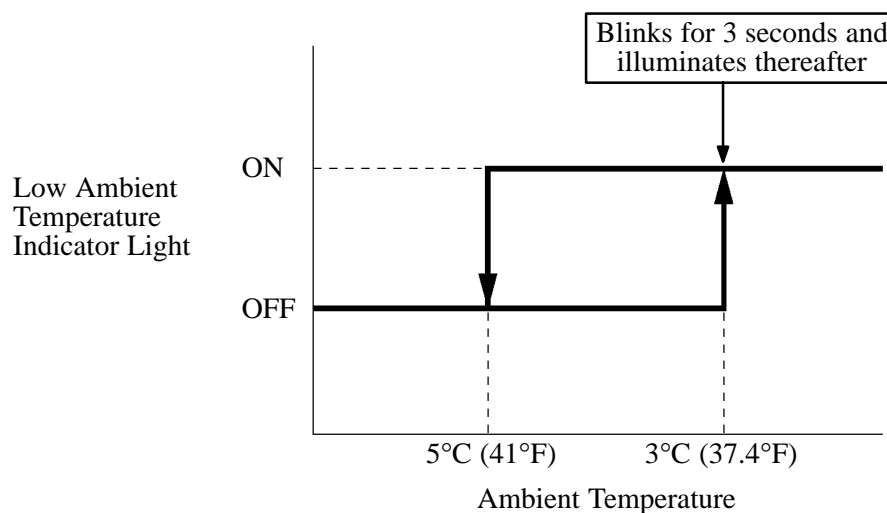

Oil Replacement Reminder Light

An oil replacement reminder light will light or flash to remind the driver to change the engine oil depending on the vehicle driving distance. Oil replacement reminder light is standard equipment only for U.S.A. model.

- Lighting and flashing of the oil replacement reminder light is operated based on the accumulated vehicle driving distance memorized in the combination meter (meter ECU).
- The meter ECU calculates the vehicle driving distance based on the signals from the brake ECU.
- This light has a bulb check function and an oil replacement reminder function.
- When turning the power switch ON, the meter ECU will turn ON the oil replacement reminder light for 3 seconds for the bulb check.
- When the accumulated vehicle driving distance memorized in the meter ECU exceeds 4500 miles after being reset, the meter ECU will flash the oil replacement reminder light for 12 seconds after the bulb check and remind the driver that the engine oil changing time is near at hand.
- When the accumulated vehicle driving distance memorized in the meter ECU exceeds 5000 miles after being reset, the meter ECU will keep the oil replacement reminder light on after the bulb check and remind the driver to change the engine oil.

► System Diagram ◀

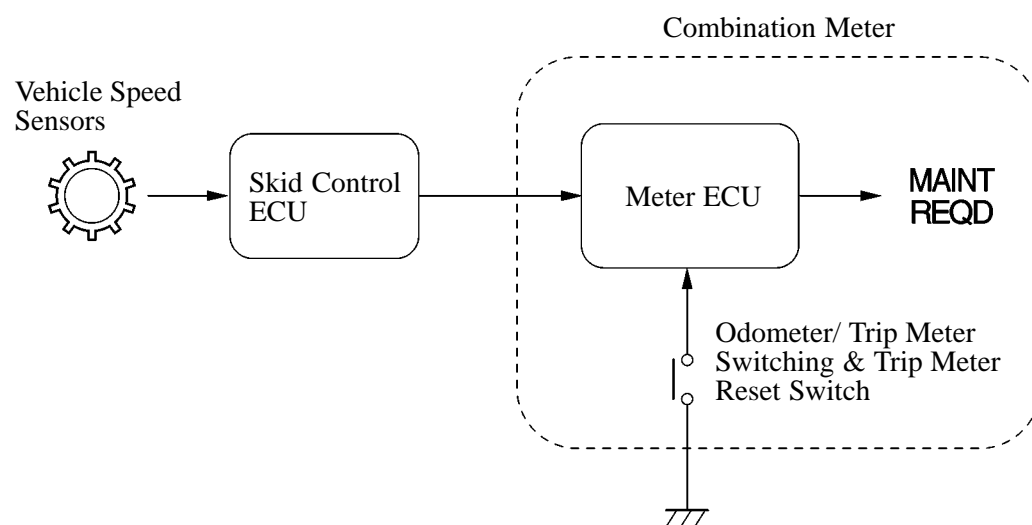

255BE33

- After the engine oil has been changed, accumulated vehicle driving distance memorized in the meter ECU should be reset by the odometer/ trip meter switching & trip meter reset switch. At this point, the accumulated vehicle driving distance is reset to zero and the cycle begins again.

Service Tip

The accumulated vehicle distance memorized in the meter ECU can be reset by the following procedures.

- 1) Turn the power switch IG-ON and make sure that the ODO/TRIP meter is the odometer display.
- 2) Turn the power switch OFF. While pushing the “ODO/ TRIP meter switching & TRIP meter reset” switch, turn the power switch IG-ON.
- 3) Until the resetting is completed, the reminder light flashes and the ODO/TRIP meter displays as shown below.
- 4) The resetting is completed when the reminder light turns OFF. Release the “ODO/TRIP meter switching & TRIP meter reset” switch.
- 5) After the resetting is completed, the ODO/TRIP meter displays as follows for 1 second. Then, the ODO/TRIP meter displays the odometer.

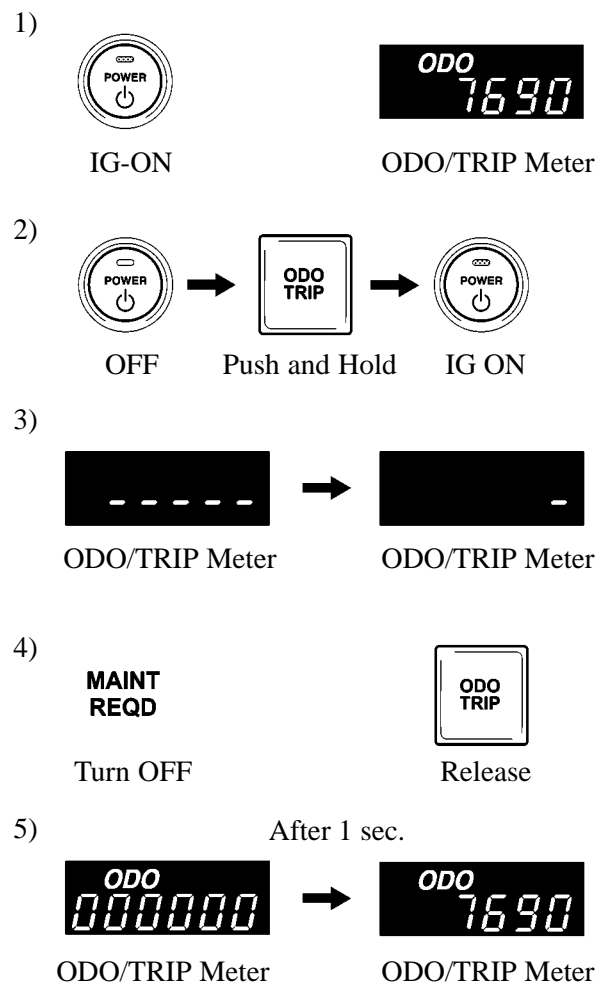
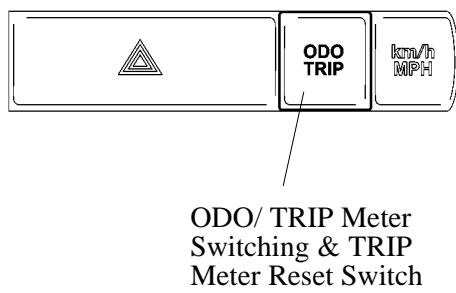
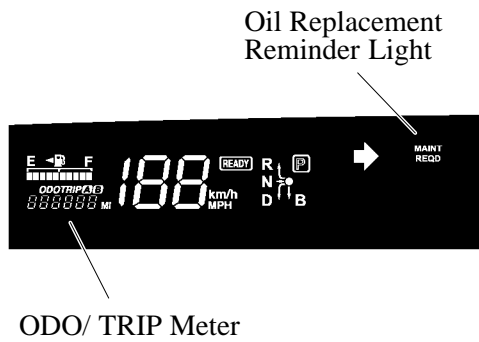

5. Fuel Gauge

General

- For the purpose of correcting the calculation of the fuel level by the meter ECU, two inclination sensors that detect the vehicle's longitudinal and latitudinal inclinations have been provided in the meter ECU, and an ambient temperature sensor has been provided in the fuel tank to detect the temperature in the fuel tank.
- The fuel level is calculated by the meter ECU in accordance with the signals of the sender gauge located in the sub tank, and the vehicle speed signal received from the skid control ECU. At this time, corrections are made by the signals from the inclination sensors that detect the vehicle's longitudinal and latitudinal inclinations and the ambient temperature sensor that detects the temperature in the fuel tank.

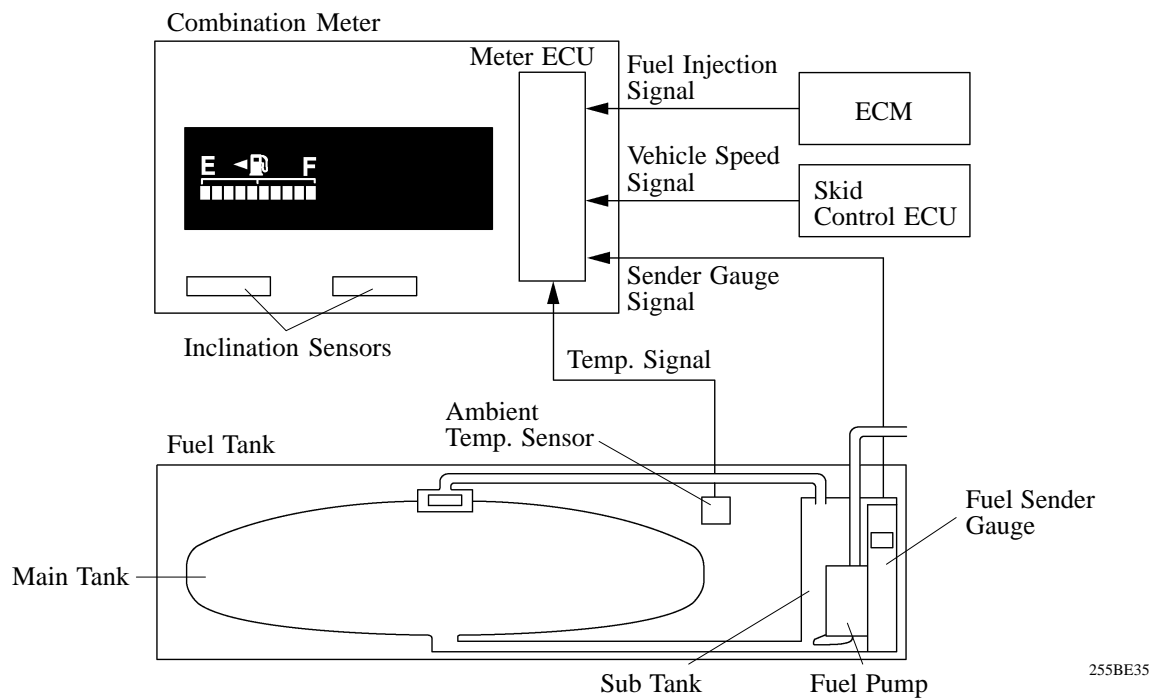

Inclination Sensor

This sensor consists of a pendulum, 2 magnets provided for the pendulum and hall IC. Hall IC converts the magnetic flux density change caused by a pendulum inclination into the voltage value and output it to the meter ECU. The meter ECU judges the inclination condition of the vehicle based on this signal and corrects the fuel gauge.

