

## ON-VEHICLE INSPECTION

### 1. HORN BUTTON ASSY (VEHICLE NOT INVOLVED IN COLLISION)

- (a) Perform a diagnostic system check (see page 05-1402).
- (b) With the horn button assy installed on the vehicle, perform a visual check. If there are any defects as mentioned below, replace the horn button assy with a new one:
  - Cuts, minute cracks or marked discoloration on the horn button assy top surface or in the grooved portion.

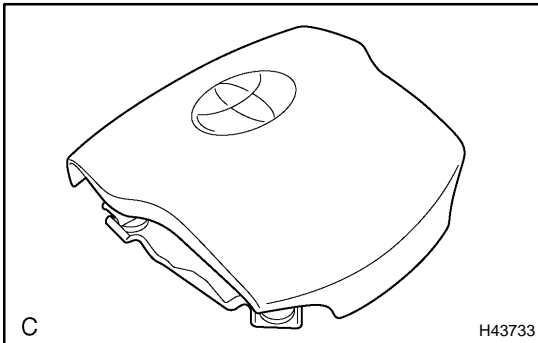

### 2. HORN BUTTON ASSY (VEHICLE INVOLVED IN COLLISION AND AIRBAG IS NOT DEPLOYED)

- (a) Perform a diagnostic system check (see page 05-1402).
- (b) With the horn button assy removed from the vehicle, perform a visual check. If there are any defects as mentioned below, replace the horn button assy or steering wheel assy with a new one:
  - Cuts, minute cracks or marked discoloration on the horn button assy top surface or in the grooved portion.
  - Cracks or other damage to the connectors.
  - Deformation of the steering wheel assy.

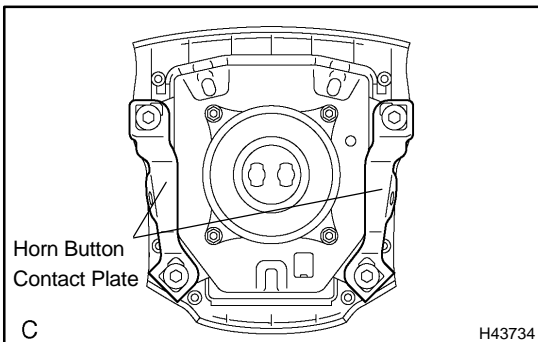

- Deformation of the horn button contact plate of the horn button assy.

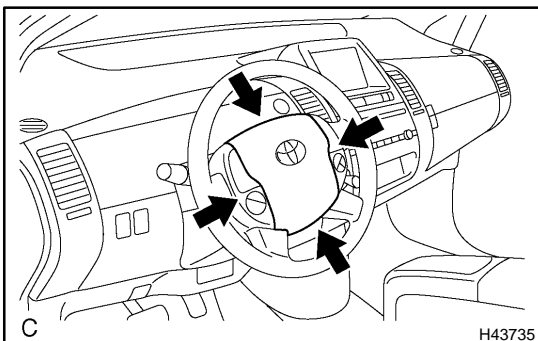

- There should be no interference between the horn button assy and steering wheel assy, and the clearance should be uniform all the way around when the new horn button assy is installed on the steering wheel assy.

### CAUTION:

For removal and installation procedures of the horn button assy, see page 60-20, and be sure to follow the correct procedure.

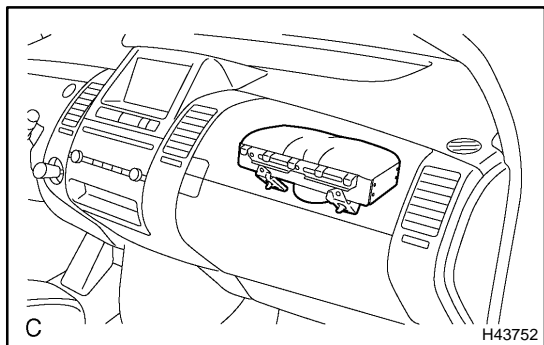

### 3. FRONT PASSENGER AIRBAG ASSY (VEHICLE NOT INVOLVED IN COLLISION)

- (a) Perform a diagnostic system check (see page 05-1402).
- (b) With the front passenger airbag assy installed on the vehicle, perform a visual check. If there are any defects as mentioned below, replace the instrument panel with a new one:

Cuts, minute cracks or marked discoloration on the instrument panel around the front passenger airbag assy.

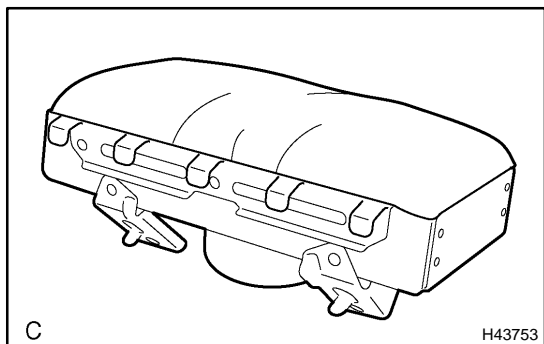

### 4. FRONT PASSENGER AIRBAG ASSY (VEHICLE INVOLVED IN COLLISION AND AIRBAG IS NOT DEPLOYED)

- (a) Perform a diagnostic system check (see page 05-1402).
- (b) With the front passenger airbag assy removed from the vehicle, perform a visual check. If there are any defects as mentioned below, replace the front passenger airbag assy, instrument panel or instrument panel reinforcement with a new one:

- Cuts, minute cracks or marked discoloration on the front passenger airbag assy.
  - Cracks or other damage to the connectors.
- 
- Deformation or cracks on the instrument panel or instrument panel reinforcement.

#### CAUTION:

For removal and installation procedures of the front passenger airbag assy, see page 60-32, and be sure to follow the correct procedure.

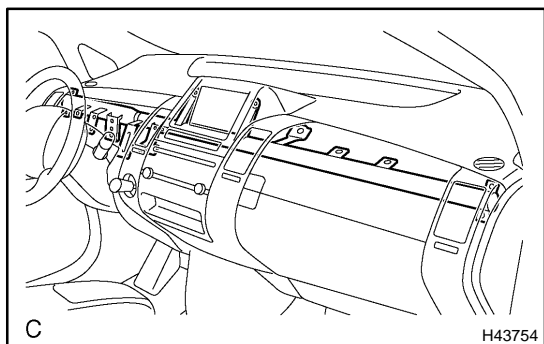

### 5. FRONT SEAT AIRBAG ASSY (VEHICLE NOT INVOLVED IN COLLISION)

- (a) Perform a diagnostic system check (see page 05-1402).
- (b) With the front seat airbag assy installed on the vehicle, perform a visual check. If there are any defects as mentioned below, replace the front seat back assy with a new one:

Cuts, minute cracks or marked discoloration on the front seat back assy around the front seat airbag assy.

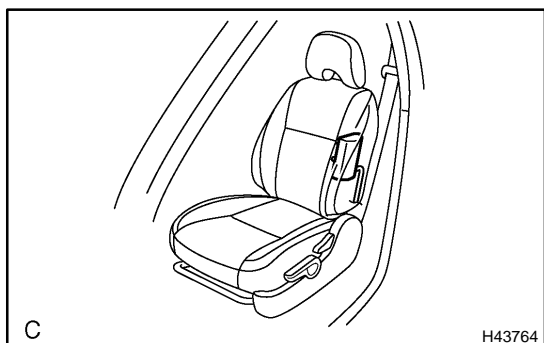

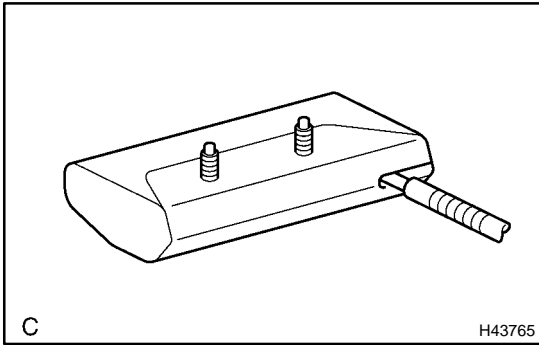

**6. FRONT SEAT AIRBAG ASSY (VEHICLE INVOLVED IN COLLISION AND AIRBAG IS NOT DEPLOYED)**

- (a) Perform a diagnostic system check (see page 05-1402).
- (b) With the front seat airbag assy removed from the vehicle, perform a visual check. If there are any defects as mentioned below, replace the front seat airbag assy with a new one:
  - Cuts, minute cracks or marked discoloration on the front seat airbag assy.
  - Cracks or other damage to the wire harness or connector.

**CAUTION:**

For removal and installation procedures of the front seat airbag assy, see page 72-2, and be sure to follow the correct procedure.

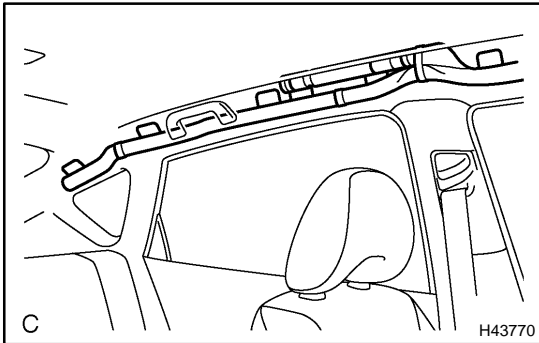

**7. CURTAIN SHIELD AIRBAG ASSY (VEHICLE NOT INVOLVED IN COLLISION)**

- (a) Perform a diagnostic system check (see page 05-1402).
- (b) With the curtain shield airbag assy installed on the vehicle, perform a visual check. If there are any defects as mentioned below, replace the front pillar garnish or roof headlining assy with a new one:
  - Cuts, minute cracks or marked discoloration on the front pillar garnish and roof headlining assy around the curtain shield airbag assy.

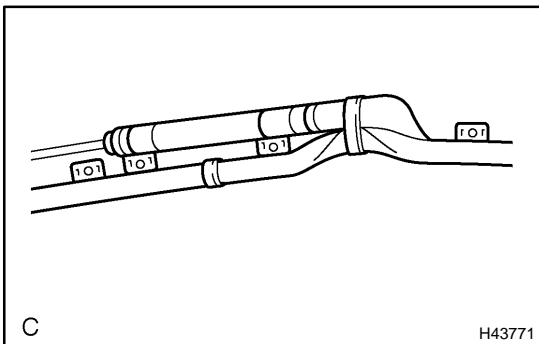

**8. CURTAIN SHIELD AIRBAG ASSY (VEHICLE INVOLVED IN COLLISION AND AIRBAG IS NOT DEPLOYED)**

- (a) Perform a diagnostic system check (see page 05-1402).
- (b) With the curtain shield airbag assy removed from the vehicle, perform a visual check. If there are any defects as mentioned below, replace the curtain shield airbag assy with a new one:
  - Cuts, minute cracks or marked discoloration on the curtain shield airbag assy.
  - Cracks or other damage to the connector.

**CAUTION:**

For removal and installation procedures of the curtain shield airbag assy, see page 60-41, and be sure to follow the correct procedure.

**9. AIRBAG ECU ASSY (VEHICLE NOT INVOLVED IN COLLISION)**

- (a) Perform a diagnostic system check (see page 05-1402).

**10. AIRBAG ECU ASSY (VEHICLE INVOLVED IN COLLISION AND AIRBAG IS NOT DEPLOYED)**

- (a) Perform a diagnostic system check (see page 05-1402).

**11. AIRBAG ECU ASSY (VEHICLE INVOLVED IN COLLISION AND AIRBAG IS DEPLOYED)**

- (a) Replace the airbag ECU assy.

**CAUTION:**

For removal and installation procedures of the airbag ECU assy, see page 60-54, and be sure to follow the correct procedure.

**12. AIRBAG SENSOR FRONT (VEHICLE NOT INVOLVED IN COLLISION)**

- (a) Perform a diagnostic system check (see page 05-1402).

**13. AIRBAG SENSOR FRONT (VEHICLE INVOLVED IN COLLISION AND AIRBAG IS NOT DEPLOYED)**

- (a) Perform a diagnostic system check (see page 05-1402).
- (b) When the front bumper of the vehicle or its periphery is damaged, check if there is any damage to the airbag sensor front. If there are any defects as mentioned below, replace the airbag sensor front with a new one:
- Cracks, dents or chips in the case.
  - Cracks or other damage to the connector.
  - Peeling off of the label or damage to the serial number.

**CAUTION:**

For removal and installation procedures of the airbag sensor front, see page 60-56, and be sure to follow the correct procedure.

**14. AIRBAG SENSOR FRONT (VEHICLE INVOLVED IN COLLISION AND AIRBAG IS DEPLOYED)**

- (a) Replace the airbag sensor front.

**CAUTION:**

For removal and installation procedures of the airbag sensor front, see page 60-56, and be sure to follow the correct procedure.

**15. SIDE AIRBAG SENSOR ASSY (VEHICLE NOT INVOLVED IN COLLISION)**

- (a) Perform a diagnostic system check (see page 05-1402).

**16. SIDE AIRBAG SENSOR ASSY (VEHICLE INVOLVED IN COLLISION AND AIRBAG IS NOT DEPLOYED)**

- (a) Perform a diagnostic system check (see page 05-1402).
- (b) When the center pillar of the vehicle or its periphery is damaged, check if there is any damage to the side airbag sensor assy. If there are any defects as mentioned below, replace the side airbag sensor assy with a new one:
- Cracks, dents or chips in the case.
  - Cracks or other damage to the connector.
  - Peeling off of the label or damage to the serial number.

**CAUTION:**

For removal and installation procedures of the side airbag sensor assy, see page 60-58, and be sure to follow the correct procedure.

**17. SIDE AIRBAG SENSOR ASSY (VEHICLE INVOLVED IN COLLISION AND AIRBAG IS DEPLOYED)**

- (a) Replace the side airbag sensor assy.

**CAUTION:**

For removal and installation procedures of the side airbag sensor assy, see page 60-58, and be sure to follow the correct procedure.

**18. AIRBAG SENSOR REAR (VEHICLE NOT INVOLVED IN COLLISION)**

- (a) Perform a diagnostic system check (see page 05-1402).

**19. AIRBAG SENSOR REAR (VEHICLE INVOLVED IN COLLISION AND AIRBAG IS NOT DEPLOYED)**

- (a) Perform a diagnostic system check (see page 05-1402).
- (b) When the quarter panel of the vehicle or its periphery is damaged, check if there is any damage to the airbag sensor rear. If there are any defects as mentioned below, replace the airbag sensor rear with a new one:
  - Cracks, dents or chips in the case.
  - Cracks or other damage to the connector.
  - Peeling off of the label or damage to the serial number.

**CAUTION:**

For removal and installation procedures of the airbag sensor rear, see page 60-60, and be sure to follow the correct procedure.

**20. AIRBAG SENSOR REAR (VEHICLE INVOLVED IN COLLISION AND AIRBAG IS DEPLOYED)**

- (a) Replace the airbag sensor rear.

**CAUTION:**

For removal and installation procedures of the airbag sensor rear, see page 60-60, and be sure to follow the correct procedure.

**21. SEAT POSITION AIRBAG SENSOR (VEHICLE NOT INVOLVED IN COLLISION)**

- (a) Perform a diagnostic system check (see page 05-1402).

**22. SEAT POSITION AIRBAG SENSOR (VEHICLE INVOLVED IN COLLISION)**

- (a) Perform a diagnostic system check (see page 05-1402).
- (b) Even if the airbag was not deployed, perform a visual check for damage to the seat position airbag sensor. If there are any defects as mentioned below, replace the seat position airbag sensor with a new one:
  - Cracks, dents or chips in the case.
  - Cracks or other damage to the connector.

**CAUTION:**

For removal and installation procedures of the seat position airbag sensor, see page 60-62, and be sure to follow the correct procedure.

**23. WIRE HARNESS AND CONNECTOR (VEHICLE NOT INVOLVED IN COLLISION)**

- (a) Perform a diagnostic system check (see page 05-1402).

**24. WIRE HARNESS AND CONNECTOR (VEHICLE INVOLVED IN COLLISION)**

- (a) Perform a diagnostic system check (see page 05-1402).
- (b) Check for breaks in all wires of the SRS wire harness and exposed conductors.
- (c) Check to see if the SRS wire harness connectors are cracked or chipped.

**HINT:**

The SRS wire harness is integrated with the engine room main wire, instrument panel wire, floor wire and floor wire No.2.