

BRAKE PEDAL ADJUSTMENT

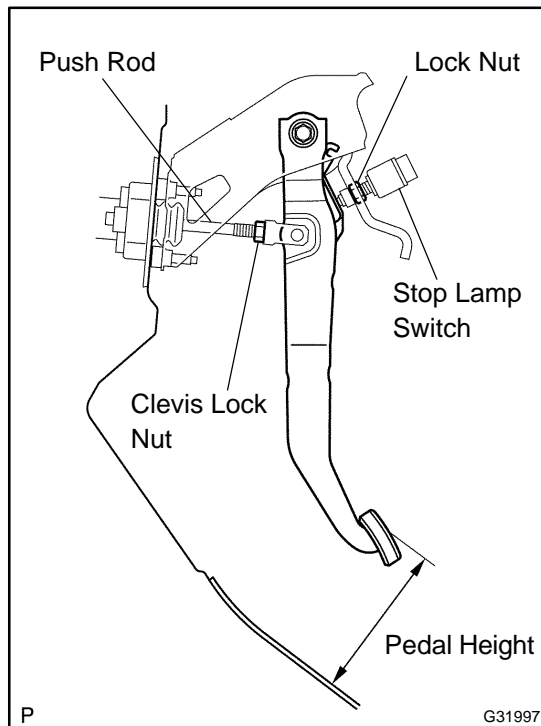

1. CHECK AND ADJUST BRAKE PEDAL HEIGHT

NOTICE:

Pull up the floor carpet and dash panel insulator assy, and then check and adjust the brake pedal height.

- Remove instrument panel finish panel LWR (see page 71-13).
- Inspect brake pedal height.
Pedal height from the top of the asphalt sheet: 138 to 148 mm (5.433 to 5.827 in.)
- Adjust brake pedal height.
 - Disconnect the connector from the stop lamp switch.
 - Loosen the stop lamp switch lock nut. Turn the switch in order to give the pedal some free play.
 - Loosen the clevis lock nut. Turn the push rod and adjust the pedal height.
 - Tighten the clevis lock nut.

Torque: 26 N·m (265 kgf·cm, 19 ft·lbf)

- Turn the stop lamp switch so that the clearance between its thread portion tip and the area where the pedal makes contact is between 0.5 to 2.4 mm (0.020 to 0.095 in.). Tighten the lock nut.

Torque: 26 N·m (265 kgf·cm, 19 ft·lbf)

- Connect the connector to the stop lamp switch.
- Connect the hand-held tester to the DLC3.
- Loosen the stroke sensor set bolts.

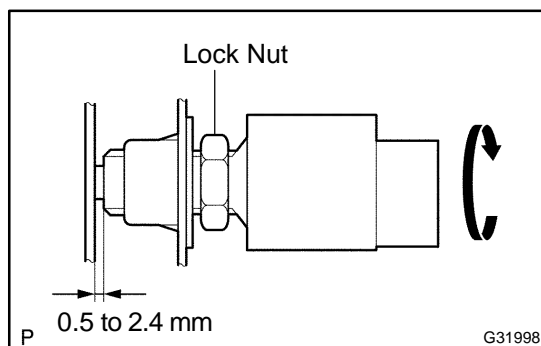

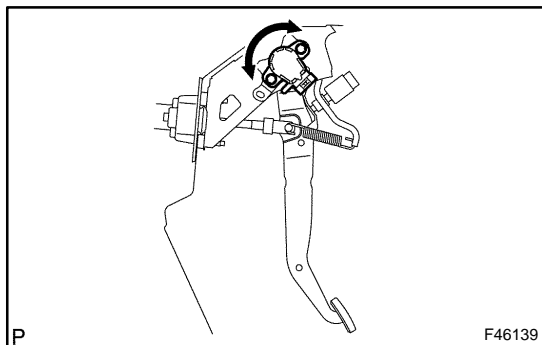

- (9) Turn the power switch on. Read the stroke sensor 1 value displayed on the data monitor using the hand-held tester. Slowly turn the stroke sensor to the right and left to adjust it to the standard value.

Standard value: 0.8 to 1.2 V

- (10) Tighten the stroke sensor set bolts.

Torque: 9.3 N·m (95 kgf·cm, 82 in.-lbf)

CAUTION:

Do not depress the brake pedal after the power switch turns on.

- (11) Carry out system initialization (see page 05-958).
 (d) Install instrument panel finish panel LWR.

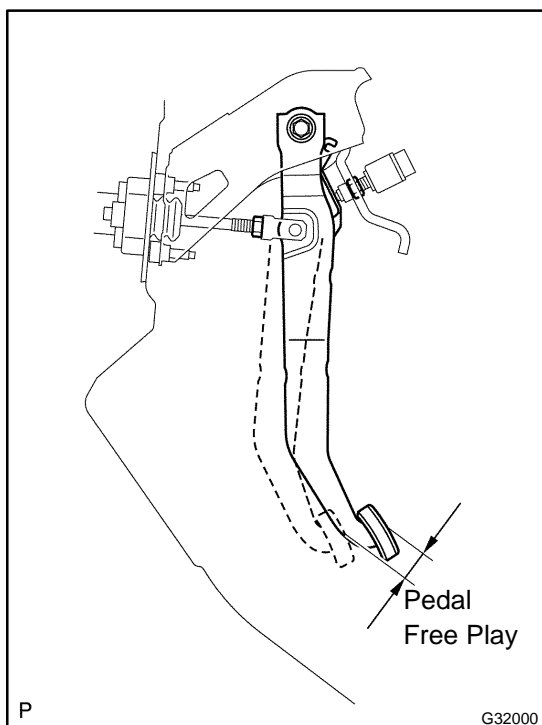

2. CHECK PEDAL FREE PLAY

- (a) Depress the brake pedal several times strongly after the engine stops.
 (b) Check the brake pedal free play.

Pedal free play: 0.5 to 4 mm (0.02 to 0.16 in.)

If incorrect, proceed to the following step.

- (1) Check the stop lamp switch clearance.

Stop lamp switch clearance:

0.5 to 2.4 mm (0.020 to 0.095 in.)

If the clearance is OK, then troubleshoot the brake system.

If incorrect, adjust the stop lamp switch clearance.

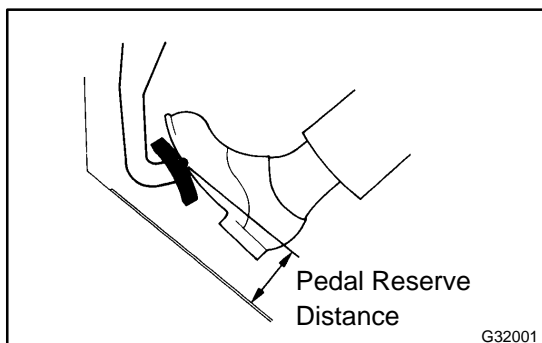

3. CHECK PEDAL RESERVE DISTANCE

- (a) Release the parking brake pedal.
 (b) With engine running, depress the pedal and measure the pedal reserve distance, as shown in the illustration.

Pedal reserve distance from the top of the asphalt sheet:

196 N (20 kgf, 44.1 lbf): More than 104 mm (4.1 in.)

NOTICE:

Pull up the floor carpet and dash panel insulator assy, and then check the brake pedal reserve distance.

If incorrect, troubleshoot the brake system.