

## OVERHAUL

### NOTICE:

- When working on the high voltage systems, always wear insulated gloves.
  - After removing the service plug grip, do not operate the power switch as it may damage the hybrid vehicle control ECU.
  - Keep the removed service plug in your pocket to prevent other technicians from reconnecting it while you are servicing the vehicle.
  - After removing the service plug grip, do not touch the high voltage connectors and terminals for 5 minutes.
1. REMOVE HYBRID VEHICLE TRANSAXLE ASSY (SEE PAGE 22-11)

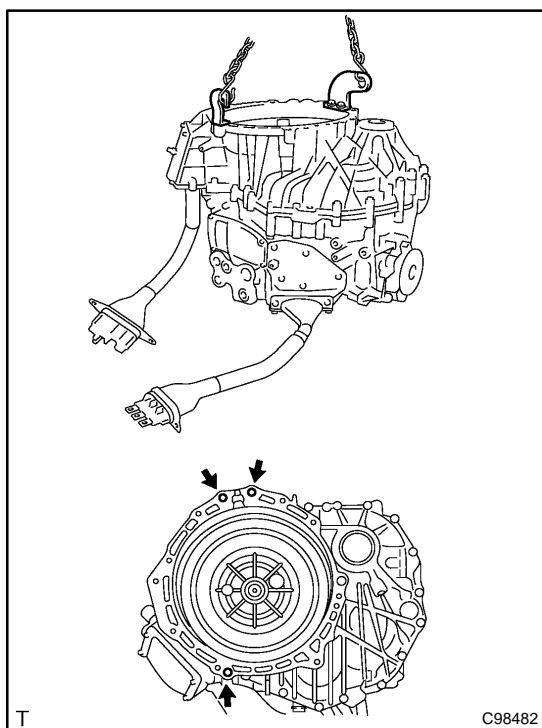

### 2. REMOVE HYBRID VEHICLE GENERATOR ASSY

- (a) Install the engine hanger in the position shown in the illustration.

#### HINT:

- Engine hanger 12281-67070, S1228-11781
  - Bolt 91642-81045, 91642-81265
  - Nut 90178-10001, 90179-12147
- (b) Using an engine sling device and chain block, set the transaxle assy with the generator side facing upward.

#### NOTICE:

- Fix the transaxle assy on a wooden block, etc.
  - Fix the transaxle assy so that no excessive force is applied to the cable.
- (c) Remove the drain plug.

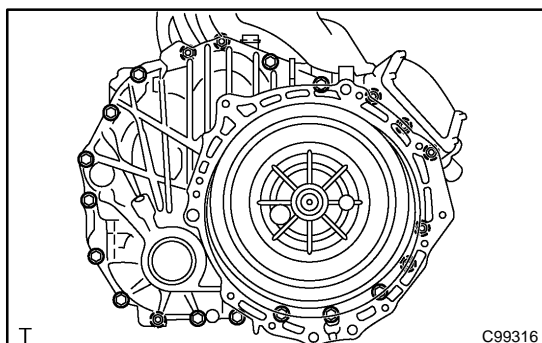

- (d) Remove the 21 bolts shown in the illustration.

#### HINT:

- 13 bolts on the generator assy side.
- 8 bolts on the motor assy side.

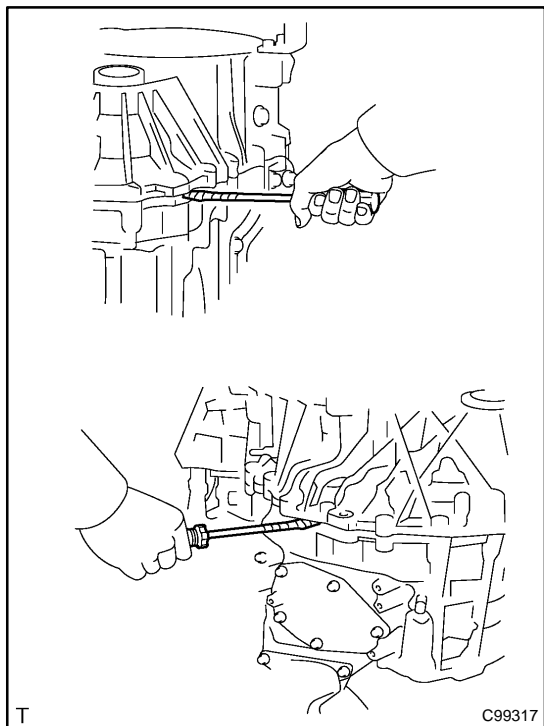

- (e) Separate the motor assy and generator assy by inserting a flat-head screwdriver in the position shown and prying the two apart.

**NOTICE:**

**Be careful not to damage the two faces of each part.**

- (f) Using an engine sliding device and a chain block, raise the generator assy.

**HINT:**

Raise the generator assy approximately 3 to 4 cm.

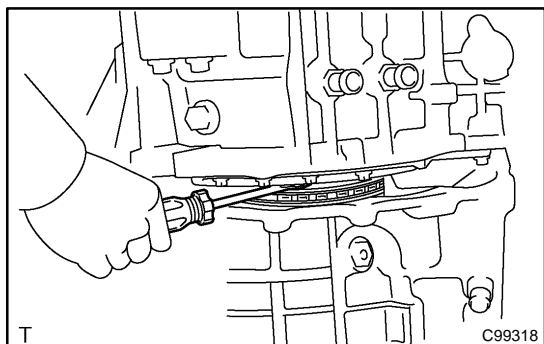

- (g) Apply protective tape to the head of a flat-head screwdriver and use it to hold down the chain with input shaft assy while removing the generator assy.

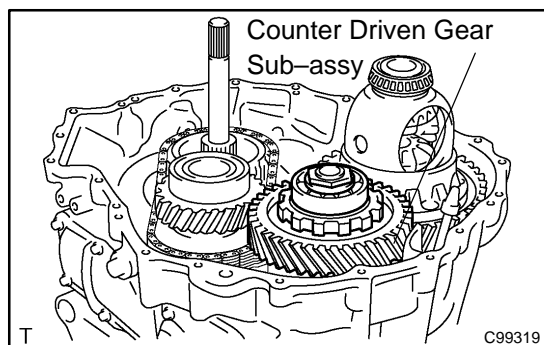
**3. REMOVE DIFFERENTIAL DRIVE PINION**

- (a) Remove the counter driven gear from the HV motor.

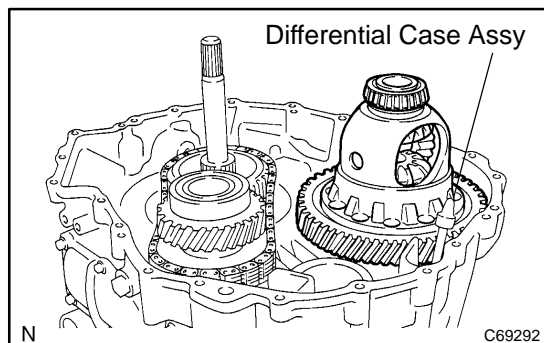
**4. REMOVE DIFFERENTIAL CASE ASSY**

- (a) Remove the differential case assy from the HV motor.

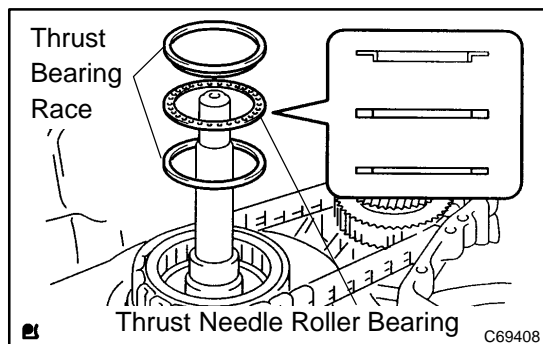

## 5. REMOVE TRANSMISSION DRIVE SPROCKET SUB-ASSY

- (a) Remove the thrust bearing race, thrust needle roller bearing and thrust bearing race No.1.

HINT:

The thrust bearing race may be attached to the generator assy side.

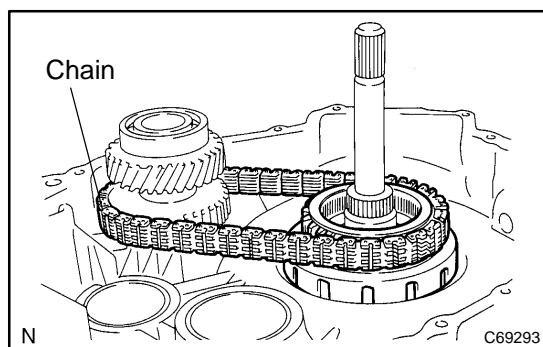

- (b) Remove the drive sprocket and chain.

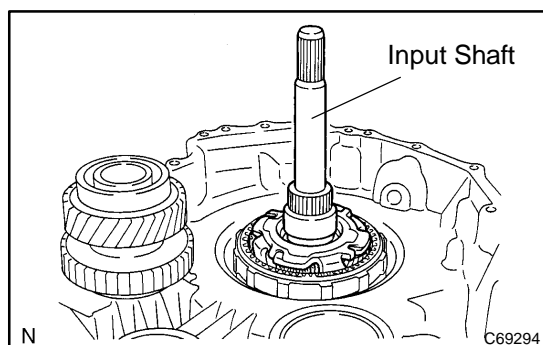

## 6. REMOVE INPUT SHAFT ASSY

- (a) Remove the input shaft assy.

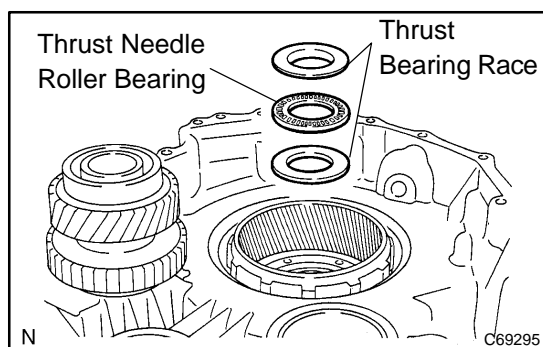

## 7. REMOVE PLANETARY RING GEAR

- (a) Remove the thrust bearing race, thrust needle roller bearing and thrust bearing race No.1.

HINT:

The thrust bearing race may be attached to the input shaft side.

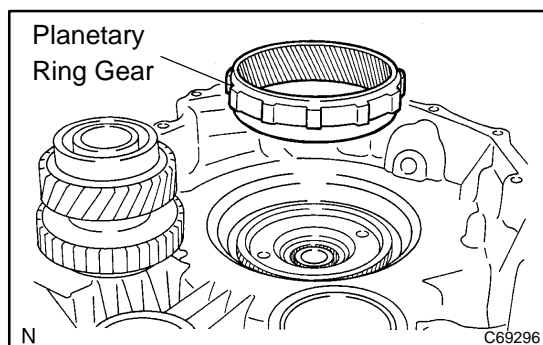

- (b) Remove the planetary ring gear.

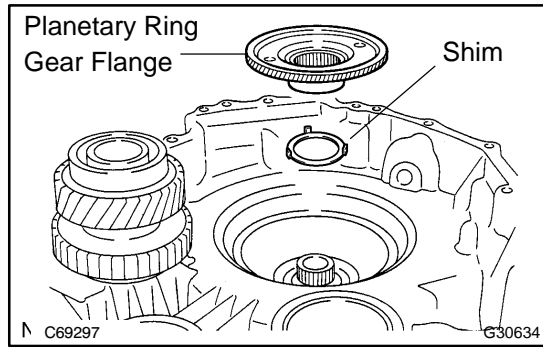

- 8. REMOVE PLANETARY RING GEAR FLANGE**  
 (a) Remove the planetary ring gear flange and shim.

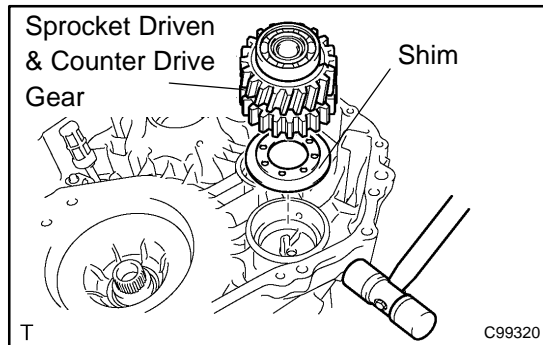

- 9. REMOVE SPROCKET DRIVEN & COUNTER DRIVE GEAR**  
 (a) Use a plastic hammer to tap the motor assy case and remove the counter drive gear and shim.  
**HINT:**  
 Remove the counter drive gear while pulling it vertically.

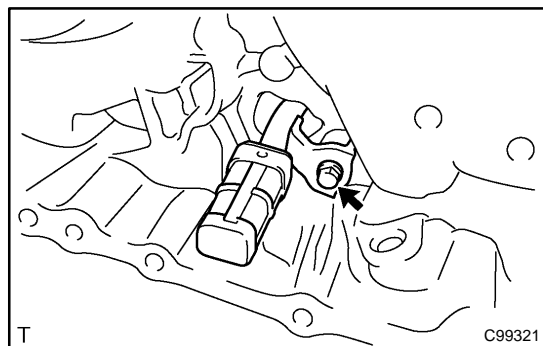

- 10. REMOVE TRANSMISSION OIL STRAINER**  
 (a) Remove the bolt and oil strainer.

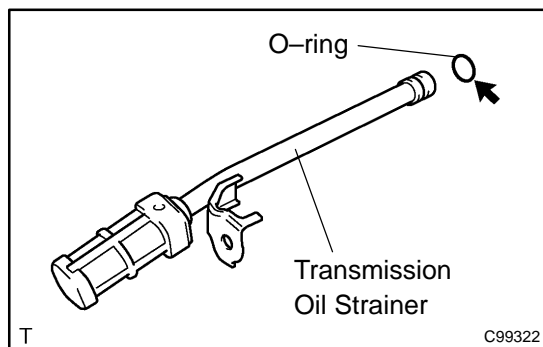

- (b) Remove the O-ring from the oil strainer.

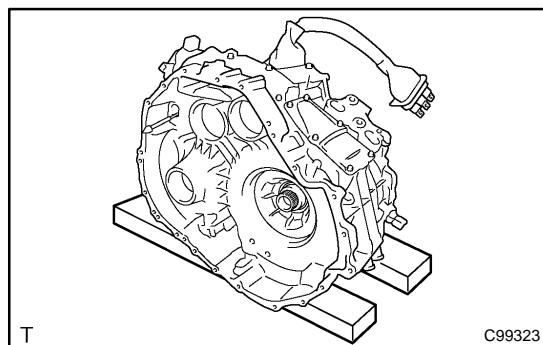

- 11. REMOVE HV MOTOR ASSY**  
 (a) Fix the motor assy on a wooden block, etc.

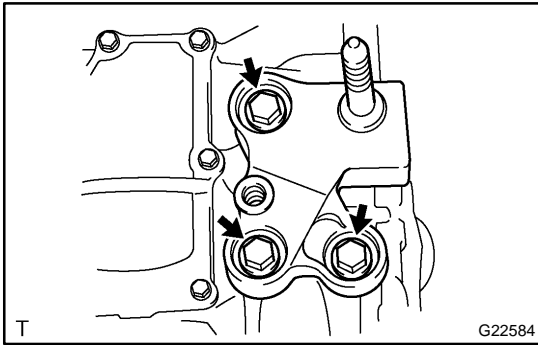

**12. REMOVE ENGINE MOUNTING BRACKET NO.3**

- (a) Remove the 3 bolts and mounting bracket.

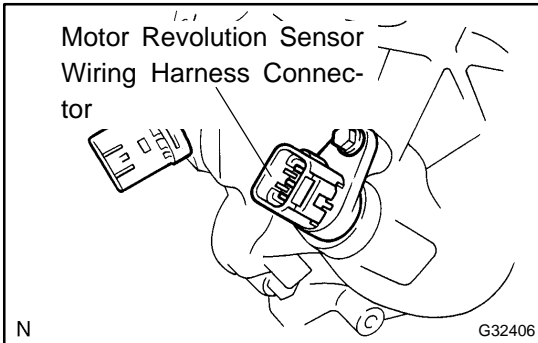

**13. REMOVE MOTOR REVOLUTION SENSOR WIRING HARNESS CONNECTOR**

- (a) Remove the bolt and pull out the HV motor side motor revolution sensor wire harness connector (gray).

**NOTICE:**

**Do not pull on the connector any more than necessary.**

- (b) Remove the connector and motor revolution sensor wire harness connector (gray).

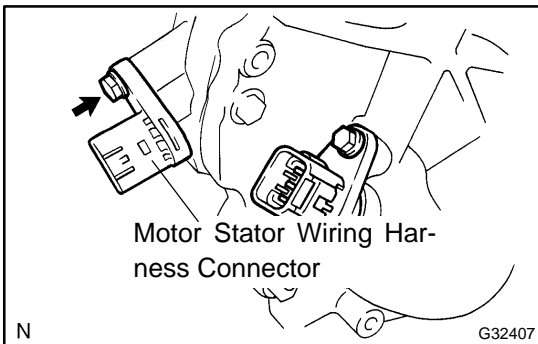

**14. REMOVE MOTOR STATOR WIRING HARNESS CONNECTOR**

- (a) Remove the bolt and pull out the motor stator wire harness connector (black).

**NOTICE:**

**Do not pull on the sensor connector any more than necessary.**

- (b) Remove the connector and the motor stator wire harness connector (black).

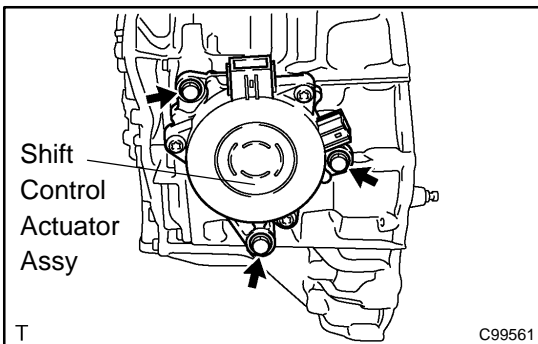

**15. REMOVE SHIFT CONTROL ACTUATOR ASSY**

- (a) Remove the 3 bolts and shift control actuator assy.

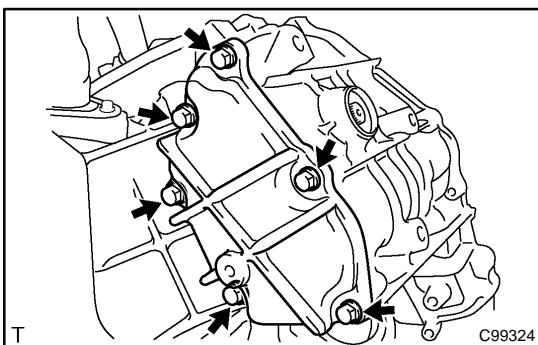

**16. REMOVE PARKING COVER**

- (a) Remove the 6 bolts and the parking cover.

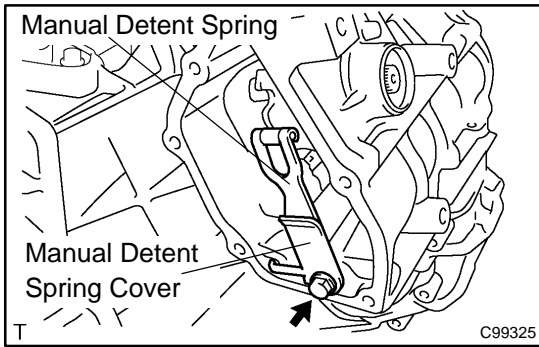

- 17. REMOVE MANUAL DETENT SPRING SUB-ASSY**  
 (a) Remove the bolt, manual detent spring cover and manual detent spring.

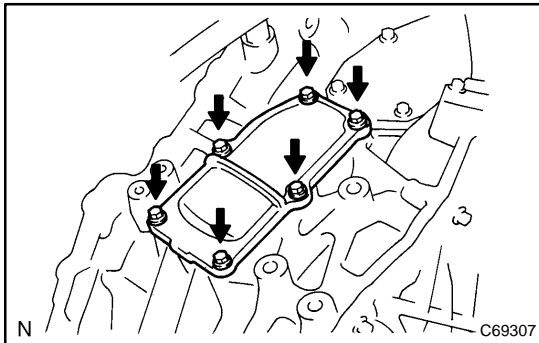

- 18. REMOVE MOTOR WATERJACET COVER**  
 (a) Remove the 6 bolts and motor water jacket cover.

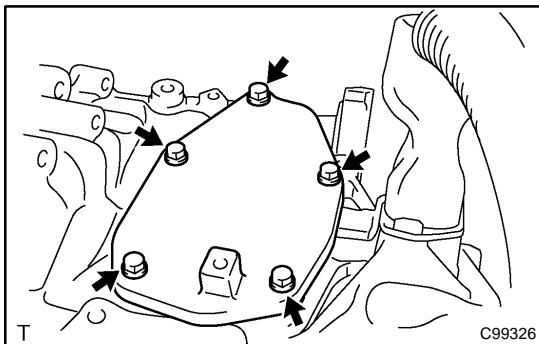

- 19. REMOVE PARKING SHAFT COVER**  
 (a) Remove the 5 bolts and the parking shaft cover.

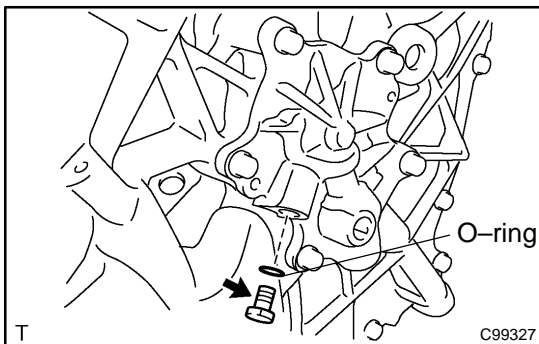

- 20. REMOVE TRANSMISSION OIL PUMP COVER SUB-ASSY**  
 (a) Remove the oil pump cover plug and O-ring.

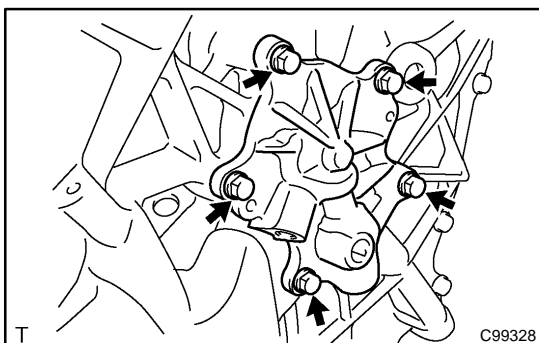

- (b) Remove the 5 bolts and oil pump cover.

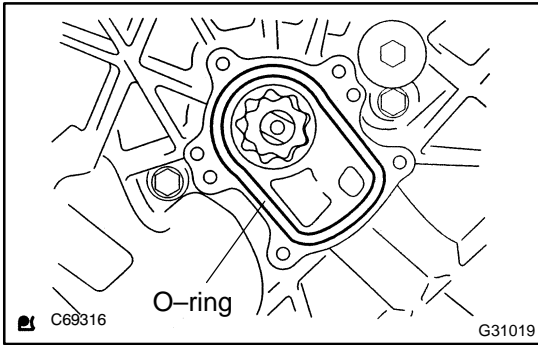

(c) Remove the O-ring.

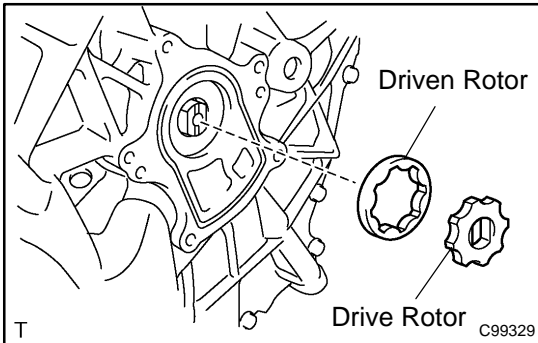

**21. REMOVE OIL PUMP DRIVE SHAFT**

(a) Remove the oil pump drive rotor and oil pump driven rotor.

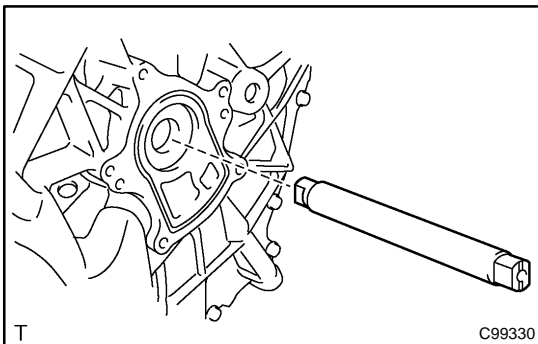

(b) Remove the oil pump drive shaft.

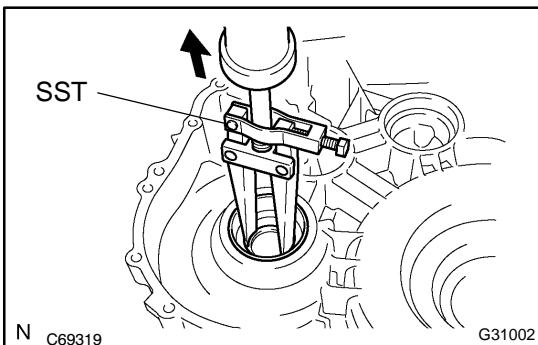

**22. REMOVE DIFFERENTIAL CASE LH TAPERED ROLLER BEARING**

(a) Using SST, remove the differential case tapered roller bearing LH outer race and shim.

SST 09308-00010

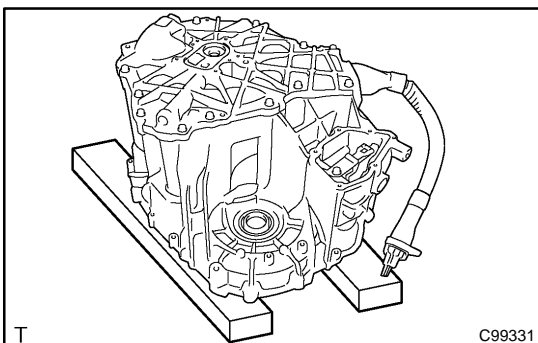

**23. REMOVE HYBRID VEHICLE TRANSAXLE ASSY TYPE T OIL SEAL**

(a) Fix the motor assy on a wooden block, etc.

**NOTICE:**

**Do not use a wooden block with the parking lock rod.**

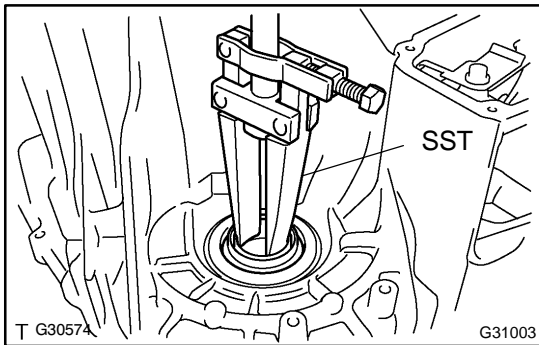

- (b) Using SST, remove the oil seal.  
SST 09308-00010

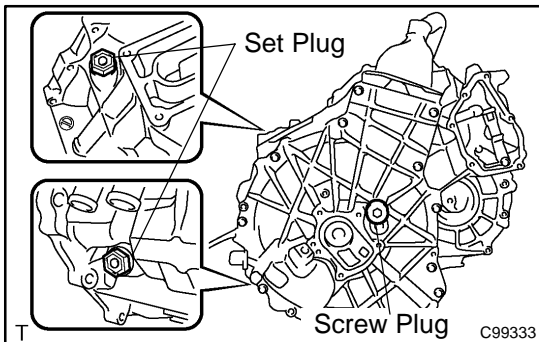

**24. REMOVE TRANSAXLE HOUSING & CASE W/HEAD STRAIGHT SCREW PLUG**

- (a) Remove the set plug and gasket.  
(b) Using a hexagon wrench (10 mm), remove the screw plugs.

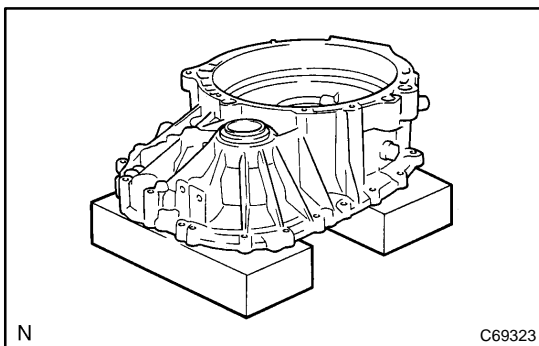

**25. FIX HYBRID VEHICLE GENERATOR ASSY**

- (a) Fix the generator assy on a wooden block, etc.

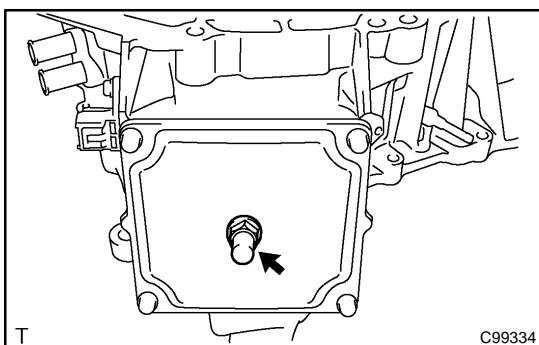

**26. REMOVE POWER CABLE COVER**

- (a) Remove the breather plug.

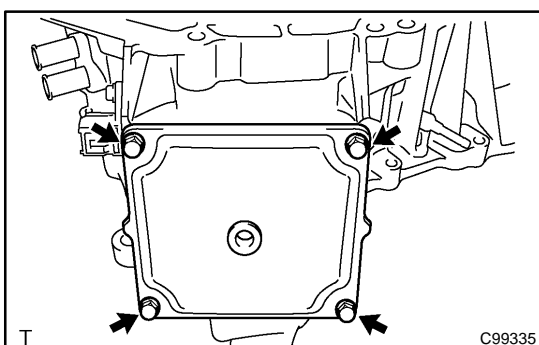

- (b) Remove the 4 bolts and power cable cover.

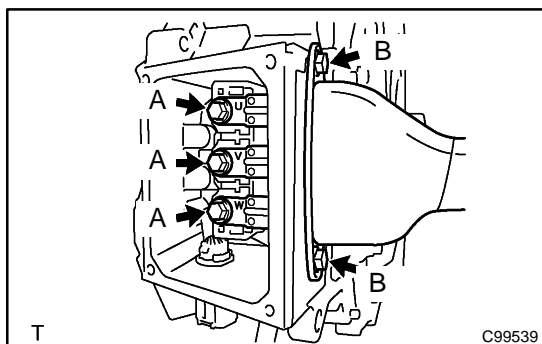

**27. REMOVE GENERATOR CABLE**

- (a) Remove the 5 bolts and generator cable.

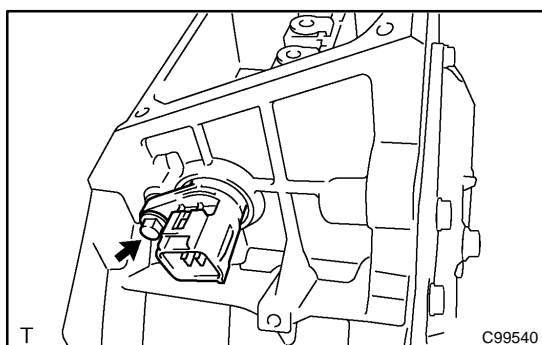
**28. REMOVE GENERATOR MOTOR REVOLUTION SENSOR WIRING HARNESS CONNECTOR**

- (a) Remove the bolt and pull out the HV generator side generator revolution sensor wire harness connector.

**NOTICE:**

**Do not pull on the sensor connector any more than necessary.**

- (b) Disconnect the connector and the HV generator side generator revolution sensor wire harness connector.

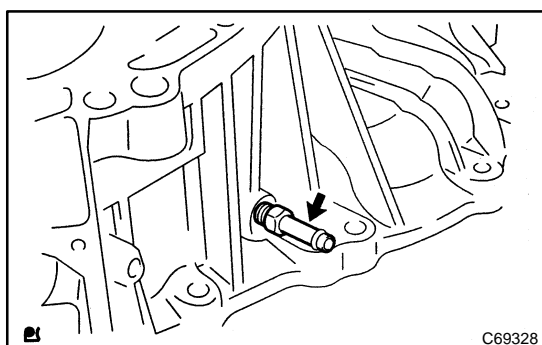
**29. REMOVE TRANSAXLE HOUSING TUBE CONNECTOR**

- (a) Remove the transaxle housing tube connector.

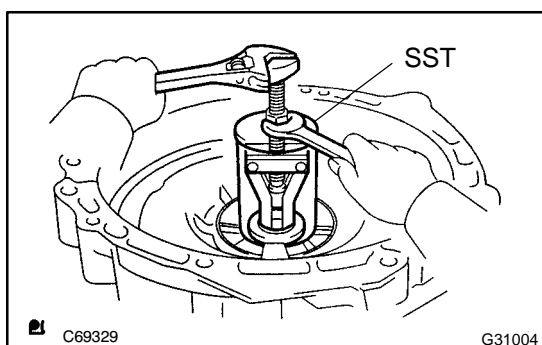
**30. REMOVE HYBRID VEHICLE TRANSAXLE ASSY TYPE T OIL SEAL**

- (a) Using SST, remove the oil seal.  
SST 09612-30012

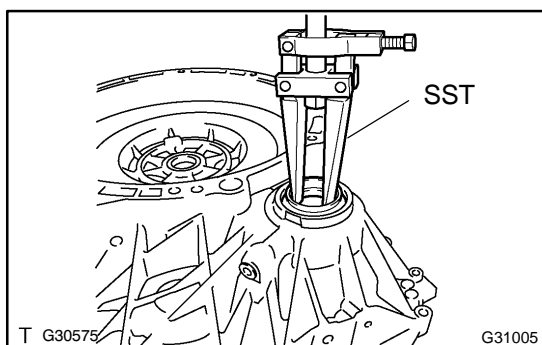
**31. REMOVE HYBRID VEHICLE TRANSAXLE ASSY TYPE T OIL SEAL**

- (a) Using SST, remove the oil seal.  
SST 09308-00010

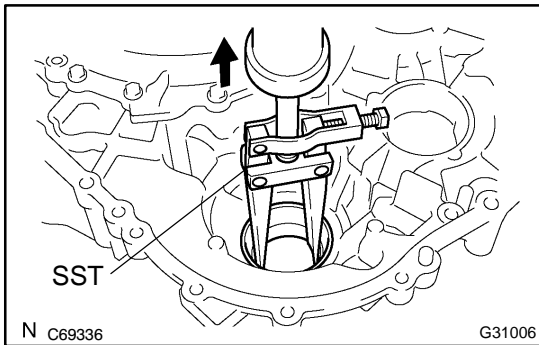

### 32. REMOVE DIFFERENTIAL CASE RH TAPERED ROLLER BEARING

- (a) Using SST, remove the differential case tapered roller bearing LH outer race.  
SST 09308-00010

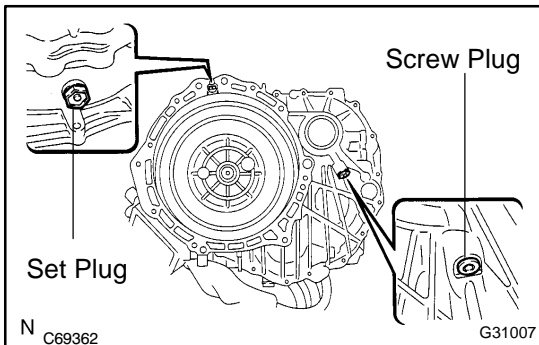

### 33. REMOVE TRANSAXLE HOUSING & CASE W/HEAD STRAIGHT SCREW PLUG

- (a) Remove the set plug and gasket.
- (b) Using a socket wrench (6 mm), remove the screw plug.

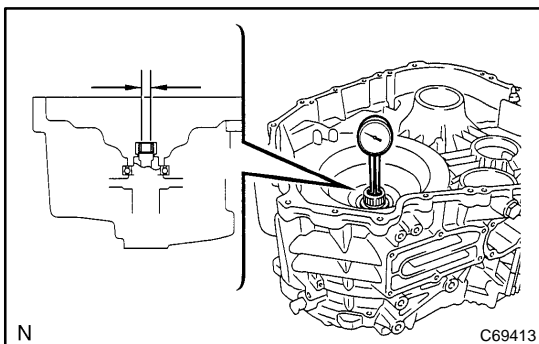

### 34. INSPECT HV MOTOR ASSY

- (a) Inspect the inside diameter of the rotor bush
  - (1) Using a dial indicator, measure the inside diameter of the motor assy rotor bush.

**Standard diameter:**

**20.025 to 20.046 mm (0.78838 to 0.78921 in.)**

**Maximum diameter:**

**20.096 mm (0.79118 in.)**

**NOTICE:**

Take the measurement in different locations and use the average of the measurements taken.

**HINT:**

If the inside diameter exceeds the maximum, replace the motor assy with a new one.

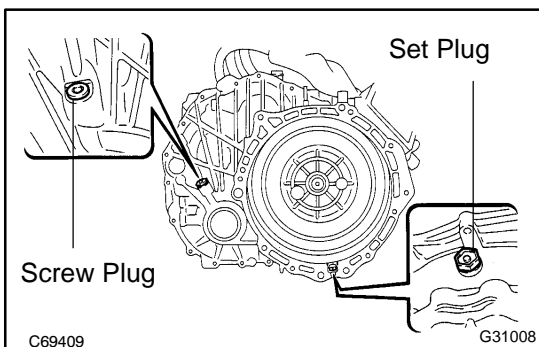

### 35. INSTALL TRANSAXLE HOUSING & CASE W/HEAD STRAIGHT SCREW PLUG

- (a) Install a new gasket and the set plug.  
**Torque: 39 N·m (400 kgf·cm, 29 ft·lbf)**
- (b) Apply liquid sealant 1344 to the first 2 to 3 threads from the end of the screw plug.

**NOTICE:**

**Clean and degrease the screw and screw hole.**

- (c) Using a socket hexagon wrench (6 mm), install the screw plug.

**Torque: 13 N·m (130 kgf·cm, 9 ft·lbf)**

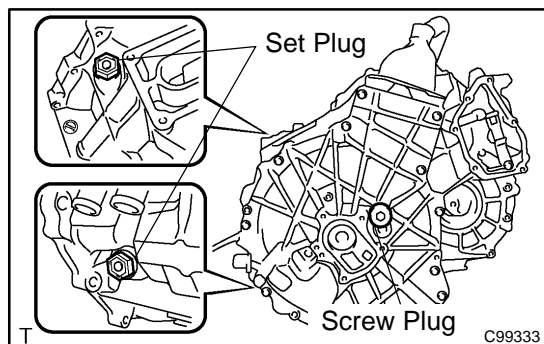

### 36. INSTALL TRANSAXLE HOUSING & CASE W/HEAD STRAIGHT SCREW PLUG

- (a) Install a new gasket and the set plug.  
**Torque: 39 N·m (400 kgf·cm, 29 ft·lbf)**

#### HINT:

Tighten the set plug after adding transaxle oil.

- (b) Apply liquid sealant 1324 to the first 2 to 3 threads from the end of the screw plug.

#### NOTICE:

**Clean and degrease the screw and screw hole.**

- (c) Using a socket hexagon wrench (10 mm), install the screw plug.

**Torque: 55 N·m (561 kgf·cm, 41 ft·lbf)**

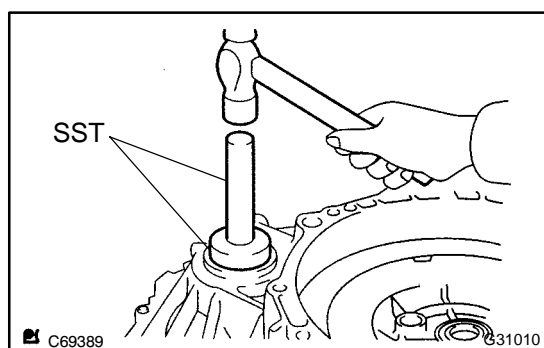

### 37. INSTALL HYBRID VEHICLE TRANSAXLE ASSY TYPE T OIL SEAL

- (a) Using SST, install a new oil seal.  
**Oil seal depth: 2.7 ± 0.5 mm (0.106 ± 0.020 in.)**

- (b) Coat the lip of the oil seal with MP grease No.2.  
 SST 09350-32014 (09351-32130, 09351-32150),  
 09950-70010 (09951-07100)

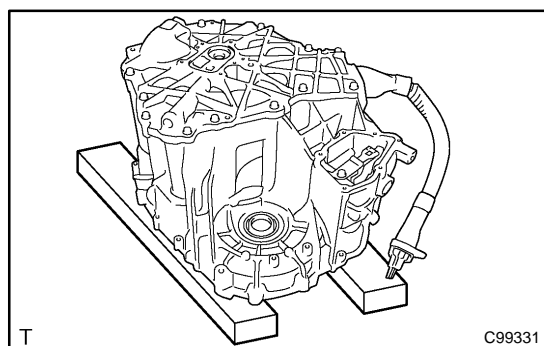

### 38. INSTALL HYBRID VEHICLE TRANSAXLE ASSY TYPE T OIL SEAL

- (a) Fix the motor assy on a wooden block, etc.

#### NOTICE:

**Do not use a wooden block with the parking lock rod.**

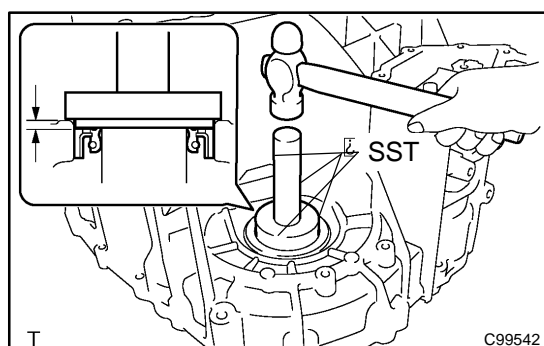

- (b) Using SST, install the oil seal.  
**Oil seal depth: 2.7 ± 0.5 mm (0.106 ± 0.020 in.)**

- (c) Coat the lip of the oil seal with MP grease No.2.  
 SST 09350-32014 (09351-32130, 09351-32150),  
 09950-70010 (09951-07100)

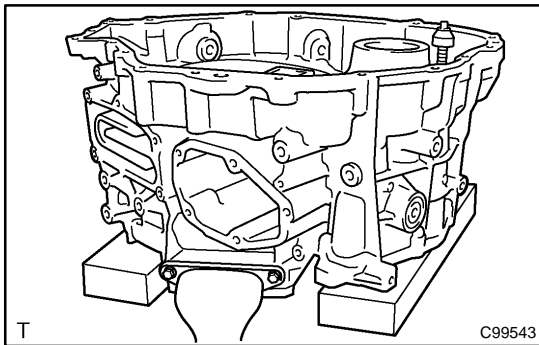

### 39. ADJUST PRELOAD

- (a) Adjust the differential case assy preload.  
 (1) Fix the motor assy on a wooden block, etc.

**NOTICE:**

- **Fix the motor assy horizontally.**
- **Unreasonable force should not be applied to the cable.**

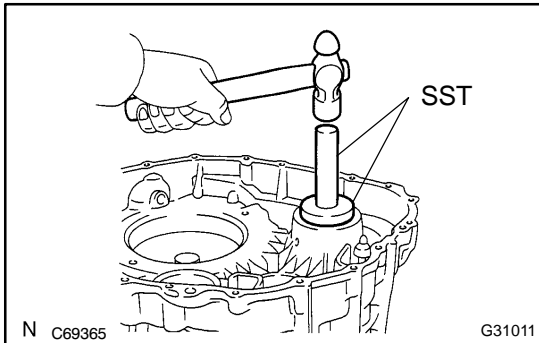

- (2) Using SST, install the differential case tapered roller bearing LH outer race and shim to the motor assy.  
 SST 09950-60020 (09951-00680), 09950-70010 (09951-07100)

**NOTICE:**

**Replace the shim and outer race with new ones if they are deformed or damaged.**

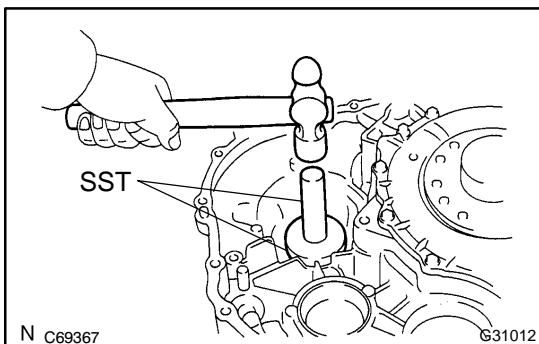

- (3) Using SST, install the differential case tapered roller bearing RH outer race to the generator assy.  
 SST 09950-60020 (09951-00680), 09950-70010 (09951-07100)

**NOTICE:**

**Replace the outer race with a new one if it is deformed or damaged.**

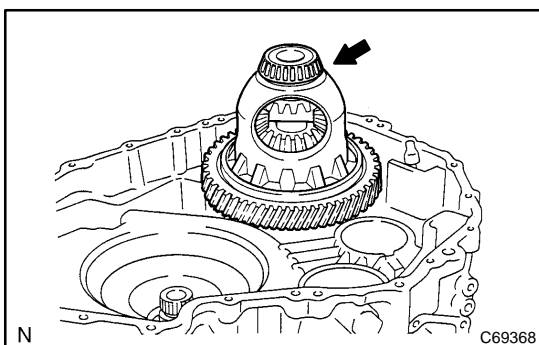

- (4) Apply ATF WS to the sliding surfaces of the differential case tapered roller bearing and install to the motor assy.

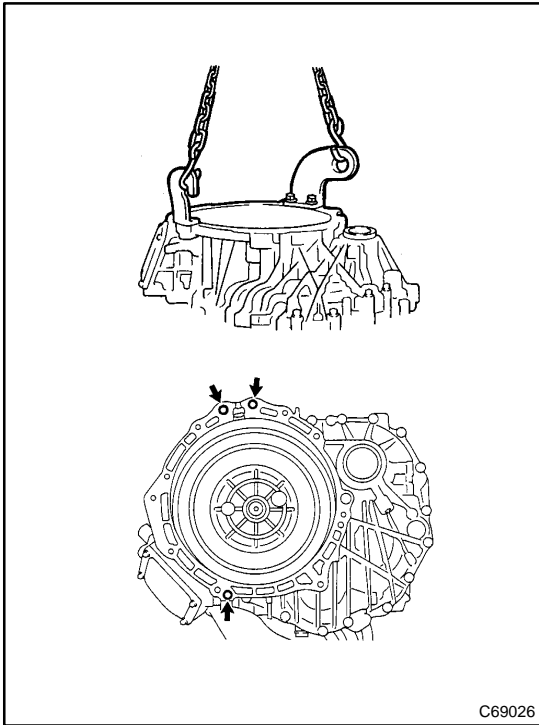

(5) Using an engine sling device and chain block, install the motor assy to the generator assy.

HINT:

- Engine hanger 12281-67070, S12228-11781
- Bolt 91642-81045, 91642-81265
- Nut 90178-10001, 90179-12147

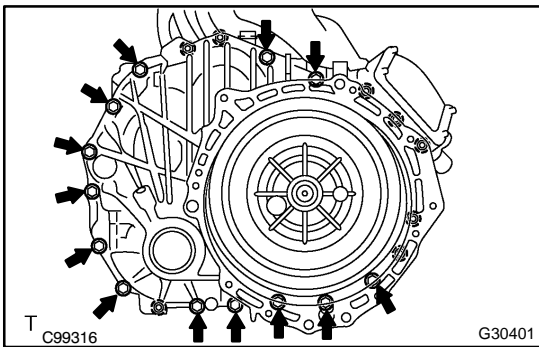

(6) Tighten the 13 bolts in the positions shown in the illustration.

**Torque: 25 N·m (250 kgf·cm, 18 ft·lbf)**

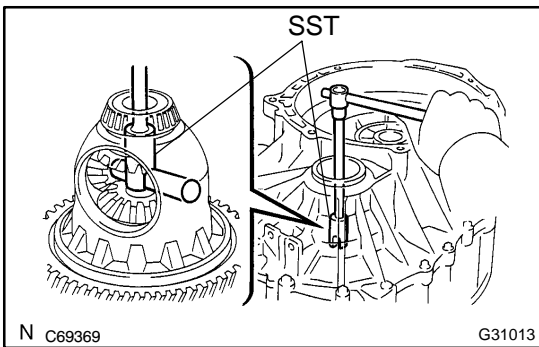

(7) Using SST, rotate the differential case assy in both directions to stabilize the bearings.

SST 09564-32011

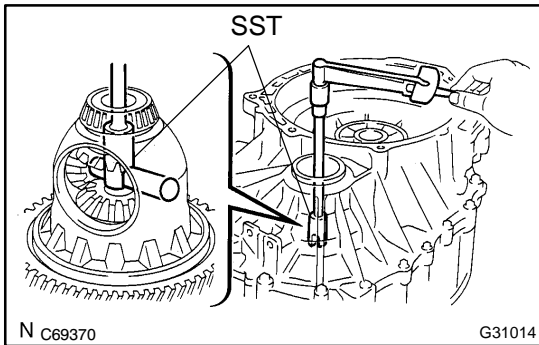

- (8) Using SST, measure the differential preload of the differential case assy and rotation torque.

SST 09564-32011

**Preload (Starting torque):**

**New bearing**

**0.98 to 1.57 N·m**

**(9.99 to 16.01 kgf·cm, 8.67 to 13.90 in.·lbf)**

**Reused bearing**

**0.49 to 0.78 N·m**

**(5.00 to 7.95 kgf·cm, 4.34 to 6.90 in.·lbf)**

**Preload (Turning torque):**

**0.61 to 1.35 N·m (20 rpm) at 20 °C**

**(6.2 to 13.77 kgf·cm, 5.4 to 11.95 in.·lbf)**

**HINT:**

- If the preload is not within the specified range, select the shim to replace.
- Remove the motor assy side tapered roller bearing outer race and shim when replacing the shim.
- Replace the shim and outer race with new ones if they are deformed or damaged.
- As the shim thickness is increased 0.02 mm (0.0008 in.), the preload increases approximately 0.23 N·m (2.4 kgf·cm 2.04 in. lbf) accordingly.

**Shim Types**

Parts Number	Thickness mm (in.)	Mark
90564-45040	1.80 (0.0709)	1
90564-45041	1.83 (0.0720)	2
90564-45042	1.86 (0.0732)	3
90564-45043	1.89 (0.0744)	4
90564-45071	1.92 (0.0756)	50
90564-45072	1.94 (0.0764)	51
90564-45073	1.96 (0.0772)	52
90564-45074	1.98 (0.0780)	53
90564-45075	2.00 (0.0787)	54
90564-45076	2.02 (0.0795)	55
90564-45077	2.04 (0.0803)	56
90564-45078	2.06 (0.0811)	57
90564-45079	2.08 (0.0819)	58
90564-45080	2.10 (0.0827)	59
90564-45081	2.12 (0.0835)	60
90564-45082	2.14 (0.0843)	61
90564-45083	2.16 (0.0850)	62
90564-45084	2.18 (0.0858)	63
90564-45085	2.20 (0.0866)	64
90564-45086	2.22 (0.0874)	65
90564-45087	2.24 (0.0882)	66
90564-45088	2.26 (0.0890)	67
90564-45089	2.28 (0.0898)	68
90564-45090	2.30 (0.0906)	69
90564-45091	2.32 (0.0913)	70
90564-45060	2.34 (0.0921)	19
90564-45061	2.37 (0.0933)	20
90564-45011	2.40 (0.0945)	No indication
90564-45062	2.43 (0.0957)	22
90564-45063	2.46 (0.0969)	23

- (9) Using an engine sling device and chain block, remove the 13 bolts and generator assy.

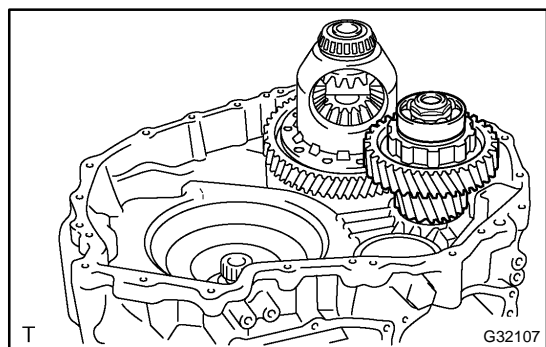
**40. INSTALL DIFFERENTIAL DRIVE PINION**

- (a) Install the differential drive pinion.

**NOTICE:**

- Insert the differential drive pinion vertically.
- Ensure that the differential drive pinion is fully inserted.

**41. SELECT THE SHIM**

- (a) Select the input shaft shim.

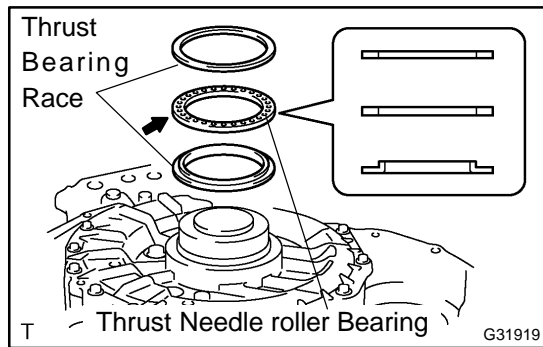

- (1) Install the thrust bearing race No.1.
- (2) Apply ATF WS to the sliding surfaces of the thrust needle roller flange and install.
- (3) Install the thrust bearing race.

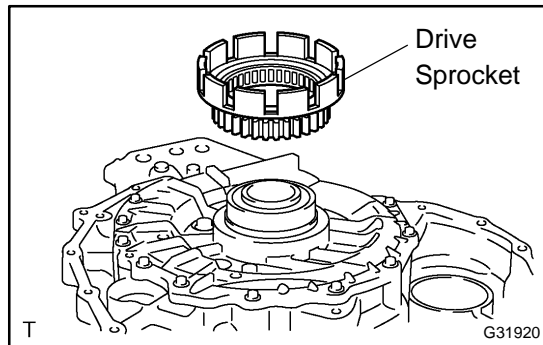

- (4) Install the drive sprocket.

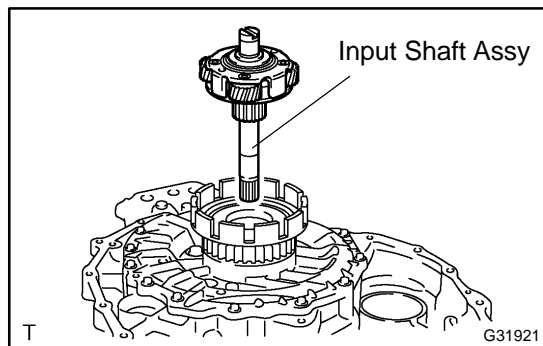

- (5) Install the input shaft assy.

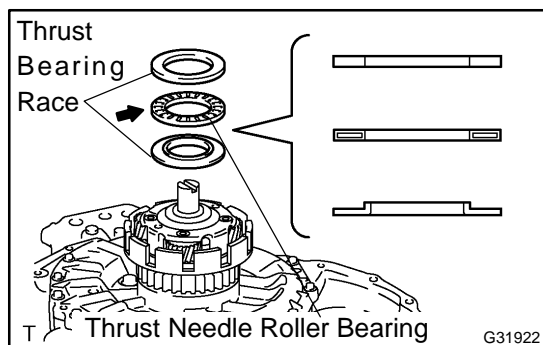

- (6) Install the thrust bearing race No.1.
- (7) Apply ATF WS to the sliding surfaces of the thrust needle roller flange and install.
- (8) Install the thrust bearing race.

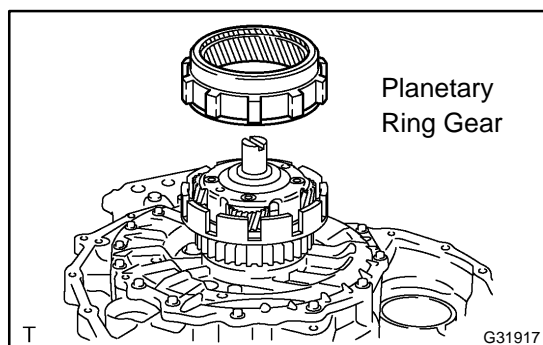

- (9) Install the planetary ring gear.



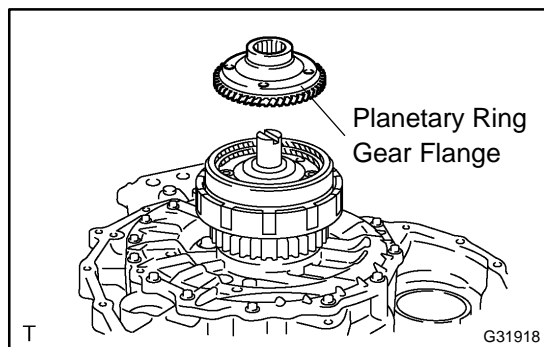

(10) Install the planetary ring gear flange.

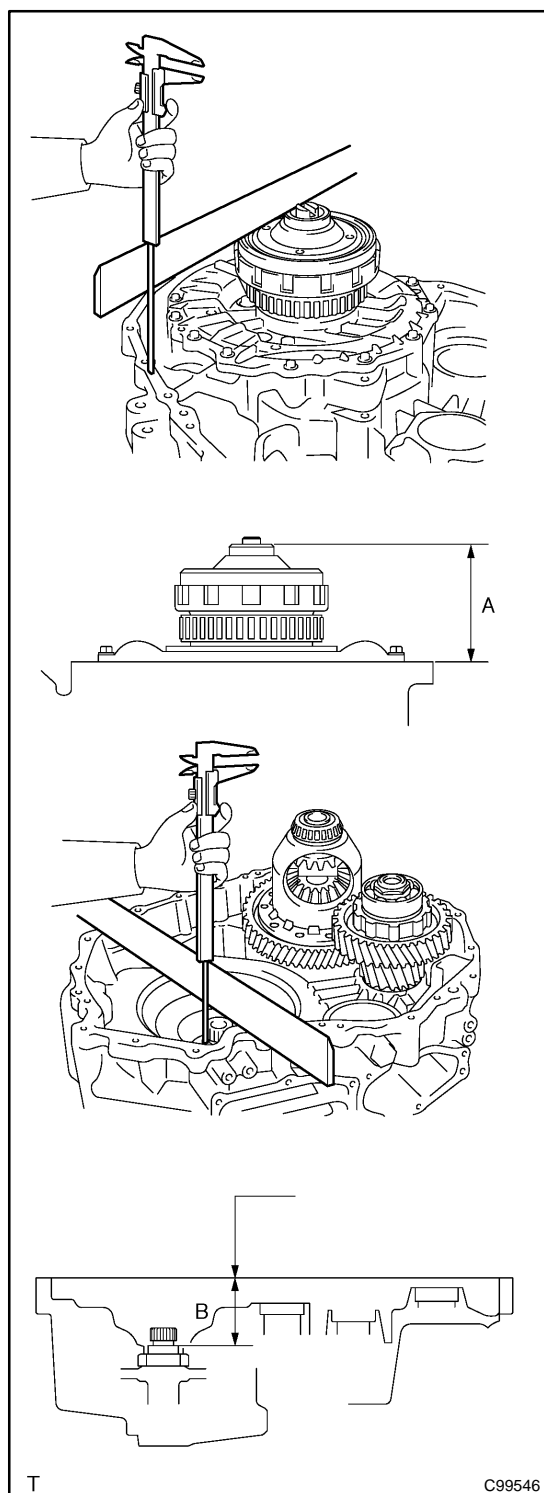

(11) Using a straight edge and vernier calipers, measure dimension A as shown in the illustration.

**Standard value: Dimension A = Measured value – width of straight edge used**

**NOTICE:**

- Measure dimension A without the shim installed.
- Take the measurement 3 times each in 3 different locations and use the average of the measurements taken.
- Two people are required for this step because it is difficult to keep the straight edge level. One person should hold the straight edge, and the other person measure dimension A.

(12) Using a straight edge and vernier calipers, measure dimension B as shown in the illustration.

**Standard value: Dimension B = Measured value – thickness of straight edge used**

**NOTICE:**

**Dimension B is greater than dimension A.**

(13) Select a shim.

**Standard value: Select shim = (Dimension B–Dimension A) – 0.1 mm (0.0039 in.) to 0.4 mm (0.0157 in.)**

**NOTICE:**

**Subtract 0.1 mm (0.0039 in.) to 0.4 mm (0.0157 in.) from the difference of Dimension B and Dimension A and select a shim on the basis of the resulting value. This is done because clearance 0.1 mm (0.0039 in.) to 0.4 mm (0.0157 in.) with the input shaft is required.**

**Shim Types**

Parts Number	Thickness mm (in.)	Mark
90564-36021	1.00 (0.0394)	1
90564-36022	1.20 (0.0472)	2
90564-36023	1.40 (0.0551)	3
90564-36024	1.60 (0.0630)	4
90564-36025	1.80 (0.0709)	5
90564-36026	2.00 (0.0787)	6
90564-36027	2.20 (0.0866)	7
90564-36028	2.40 (0.0945)	8
90564-36029	2.60 (0.1024)	9
90564-36030	2.80 (0.1102)	10
90564-36031	3.00 (0.1181)	11
90564-36032	3.20 (0.1260)	12

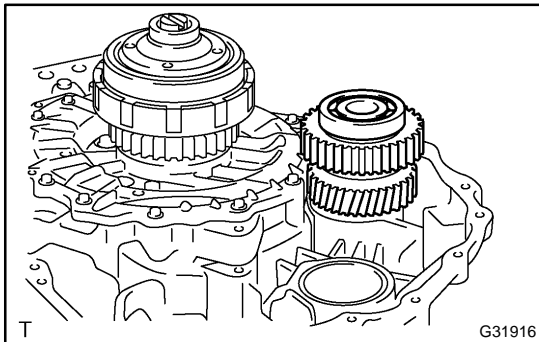

(b) Select a counter drive gear shim.

(1) Install the counter drive gear.

**NOTICE:**

- **Insert the counter drive gear vertically.**
- **Ensure that the counter drive gear is fully inserted.**

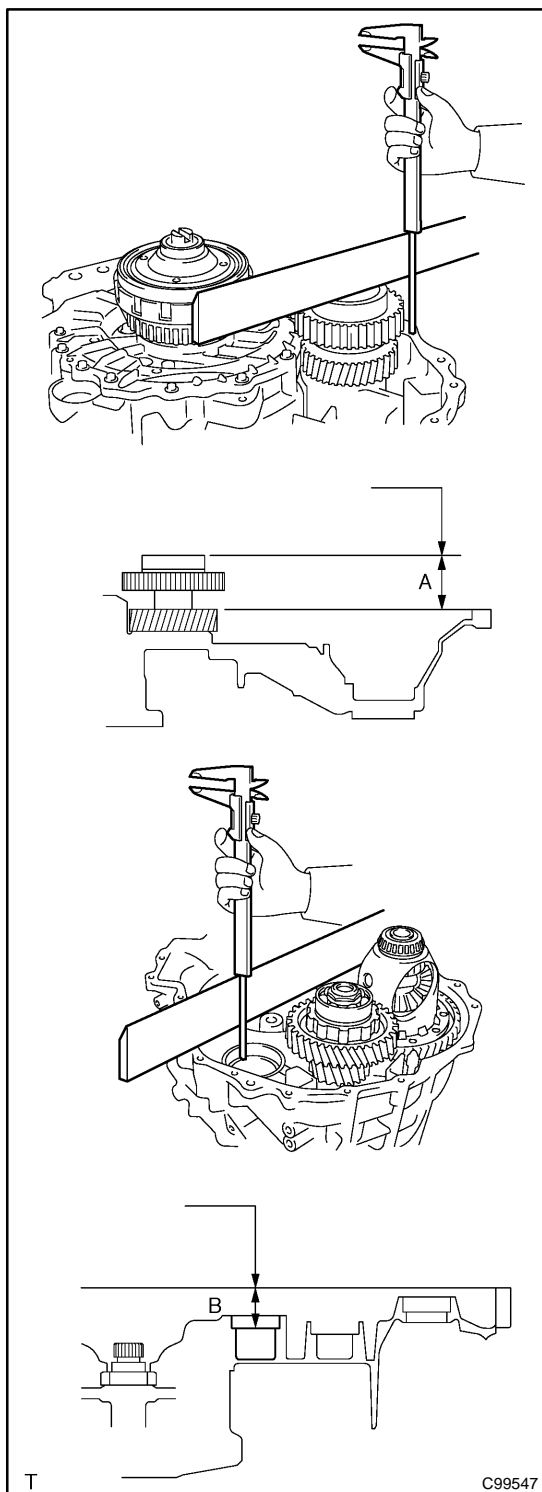

- (2) Using a straight edge and vernier calipers, measure dimension A as shown in the illustration.

**Standard value: Dimension A = Measured value – width of straight edge used**

**NOTICE:**

- Measure dimension A without the shim installed.
- Take the measurement 3 times each in 3 different locations and use the average of the measurements taken.
- Two people are required for this step because it is difficult to keep the straight edge level. One person should hold the straight edge, and the other person measure dimension A.

- (3) Using a straight edge and vernier calipers, measure dimension B as shown in the illustration.

**Standard value: Dimension B = Measured value – thickness of straight edge used**

**NOTICE:**

**Dimension B is greater than dimension A.**

(4) Select a shim.

**Standard value: Selected shim = (Dimension B-Dimension A) - 0 mm (0 in.) to 0.1 mm (0.0039 in.)**

**NOTICE:**

**Subtract 0 mm (0 in.) to 0.1 mm (0.0039 in.) from the difference of Dimension B and Dimension A and select a shim on the basis of the resulting value. This is done because clearance 0 mm (0 in.) to 0.1 mm (0.0039 in.) with the counter drive gear is required.**

**Shim Types**

Parts Number	Thickness mm (in.)	Marks
90564-35132	2.20 (0.0866)	A
90564-35133	2.25 (0.0886)	B
90564-35134	2.30 (0.0906)	C
90564-35135	2.35 (0.0925)	D
90564-35136	2.40 (0.0945)	E
90564-35137	2.45 (0.0965)	F
90564-35138	2.50 (0.0984)	G
90564-35139	2.55 (0.1003)	H
90564-35140	2.60 (0.1024)	J
90564-35141	2.65 (0.1043)	K
90564-35142	2.70 (0.1063)	L
90564-35143	2.75 (0.1083)	M
90564-35144	2.80 (0.1102)	N

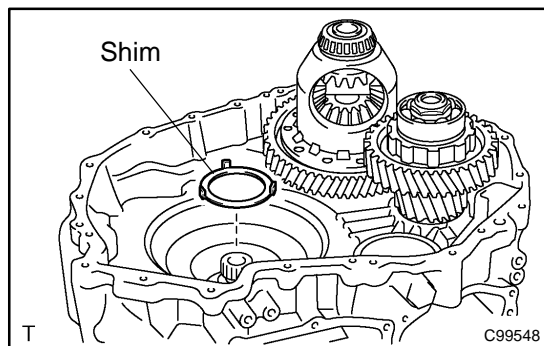

**42. INSTALL INPUT SHAFT ASSY**

(a) Install the shim selected.

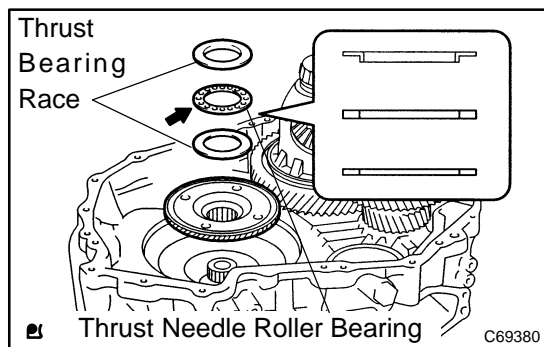

(b) Install the planetary ring gear flange.

(c) Install the thrust bearing race No.1.

(d) Install the thrust needle roller bearing.

(1) Apply ATF WS to the sliding surfaces of the thrust needle roller flange and install.

(e) Install the thrust bearing race.

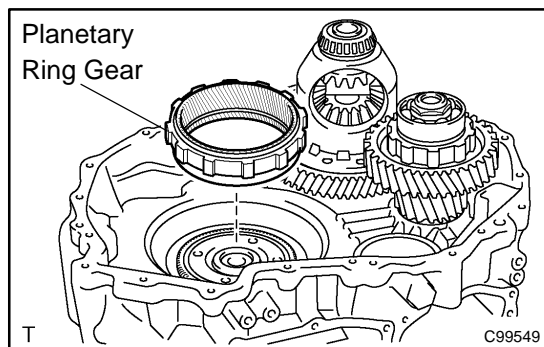

- (f) Install the planetary ring gear.

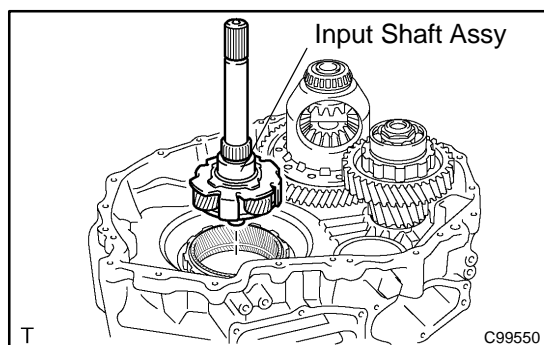

- (g) Install the input shaft assy.

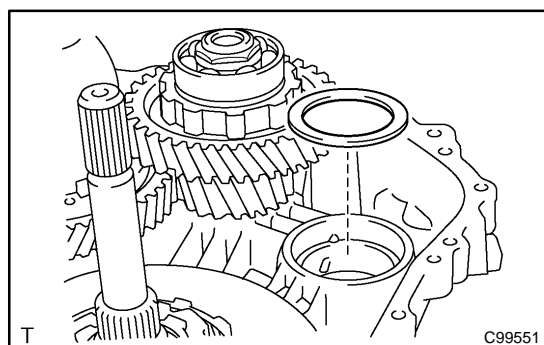

#### 43. INSTALL SPROCKET DRIVEN & COUNTER DRIVE GEAR

- (a) Install the counter drive gear selected.

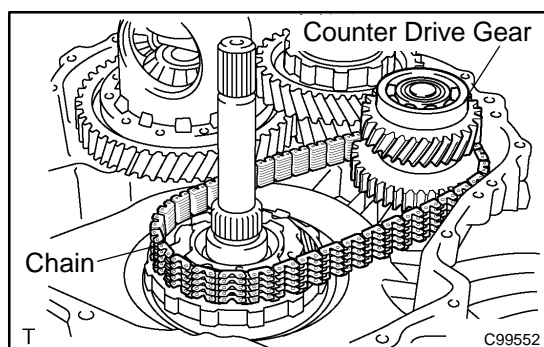

- (b) Install the counter drive gear and chain.

#### NOTICE:

- Insert the counter drive gear vertically.
- Ensure that the counter drive gear is fully inserted.

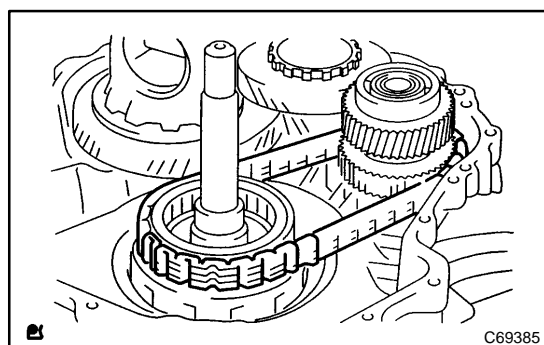

#### 44. INSTALL TRANSMISSION DRIVE SPROCKET SUB-ASSY

- (a) Apply ATF WS auto fluid to the drive sprocket needle roller bearing and put the drive sprocket on the chain.
- (b) Align the recesses of the planetary ring gear and the drive sprocket and install the drive sprocket with chain.

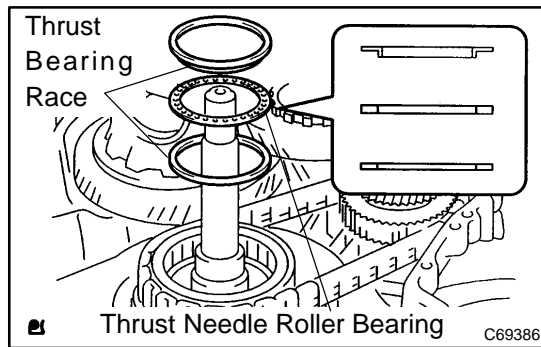
**45. INSTALL THRUST BEARING RACE NO.2**

- (a) Install the drive sprocket thrust needle roller bearing No.1.
- (b) Install the thrust bearing race No.2.

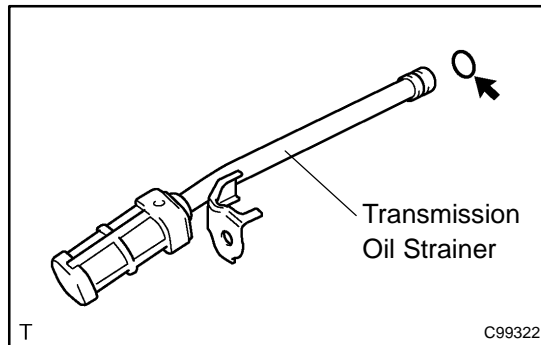
**46. INSTALL TRANSMISSION OIL STRAINER**

- (a) Apply ATF WS to a new O-ring and install the fluid strainer.

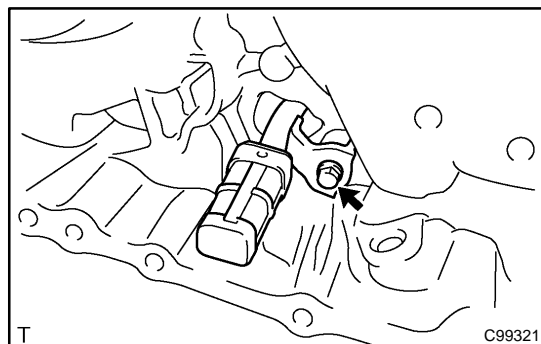

- (b) Install the bolt and oil strainer.

**Torque: 7.9 N·m (81 kgf·cm, 70 in.-lbf)**

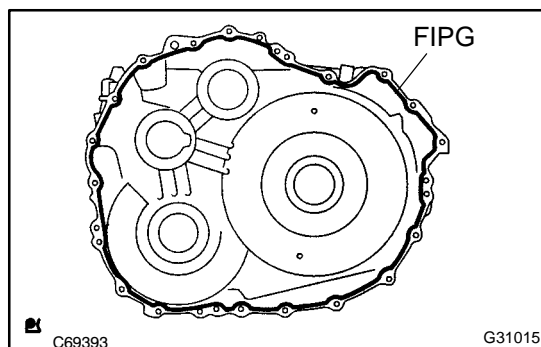
**47. INSTALL HYBRID VEHICLE GENERATOR ASSY**

- (a) Apply seal packing 1281 in a continuous line of beads (diameter 1.5 mm 0.059 in.) to the motor assy side.

**NOTICE:**

- **Clean and degrease the installation surfaces.**
- **Install within 10 minutes of applying seal packing.**

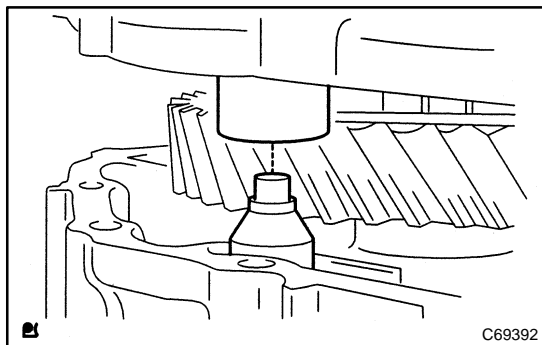

- (b) Install the parking lock rod to the generator assy so that it is inserted into the cam guide sleeve. Use an engine sling device and chain block.

**NOTICE:**

Rotate the input shaft in both directions so that the gears interlock if the generator assy cannot be easily installed.

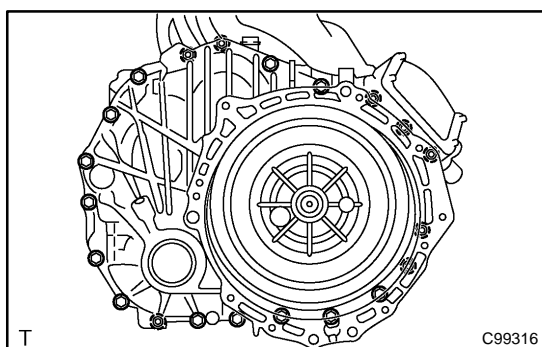
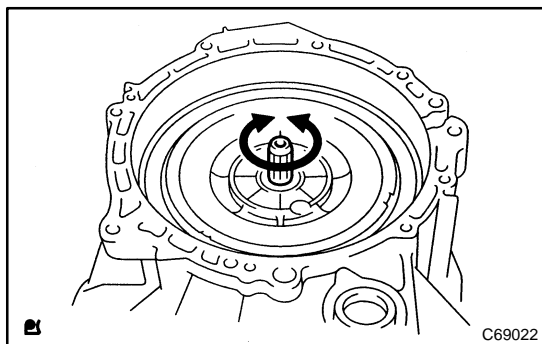

- (c) Apply liquid sealant 1344 to the first 2 to 3 threads of the bolt (45 mm 1.772 in. long shaft) end.

**NOTICE:**

Clean and degrease the bolt and bolt holes.

- (d) Install the 21 bolts as shown in the illustration.

**Torque: 25 N·m (250 kgf·cm, 18 ft·lbf)**

**HINT:**

- 13 bolts on the generator assy side
- 8 bolts on the motor assy side

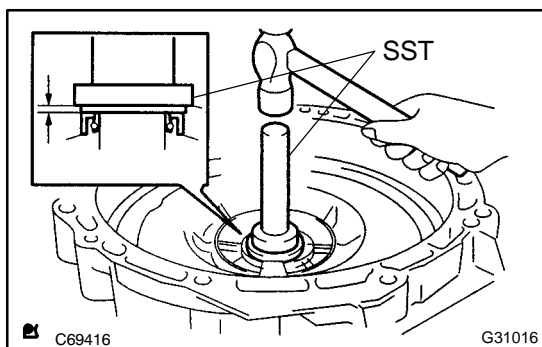

#### 48. INSTALL HYBRID VEHICLE TRANSAXLE ASSY TYPE T OIL SEAL

- (a) Coat the lip of the oil seal with MP grease No.2.

**NOTICE:**

Ensure that no foreign objects adhere to the oil seal lip.

- (b) Using SST, install a new oil seal.

**Oil seal depth: 1 to 1.5 mm (0.039 to 0.059 in.)**

**NOTICE:**

Ensure that the oil seal is fitted straight.

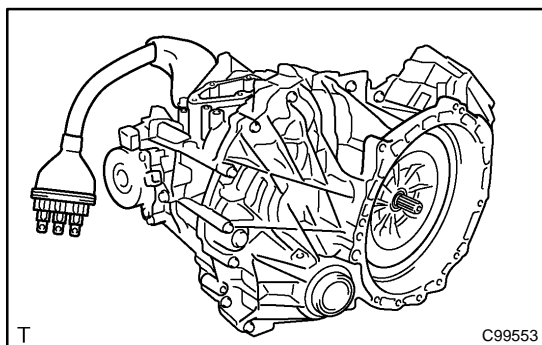

#### 49. FIX HYBRID VEHICLE TRANSAXLE ASSY

- (a) Set the hybrid transaxle as shown in the illustration.

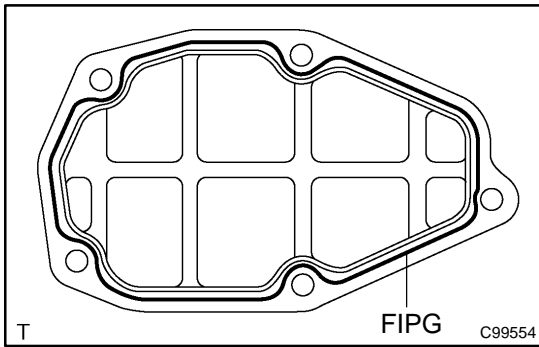
**50. INSTALL PARKING COVER**

- (a) Apply seal packing 1281 in a continuous line of beads (diameter 1.5 mm, 0.06 in) as shown in the illustration.

**NOTICE:**

- **Clean and degrease the installation surfaces.**
- **Install within 10 minutes of applying seal packing.**

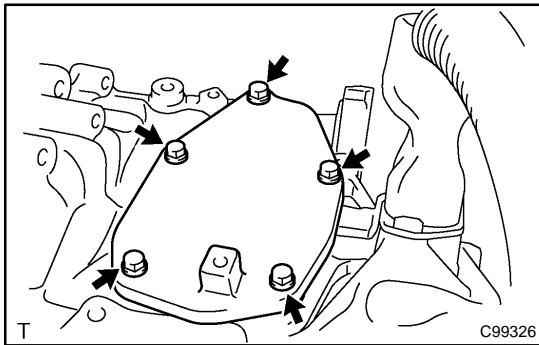

- (b) Install the 5 bolts and parking shaft cover.

**Torque: 5.5 N·m (56 kgf·cm, 49 in.-lbf)**

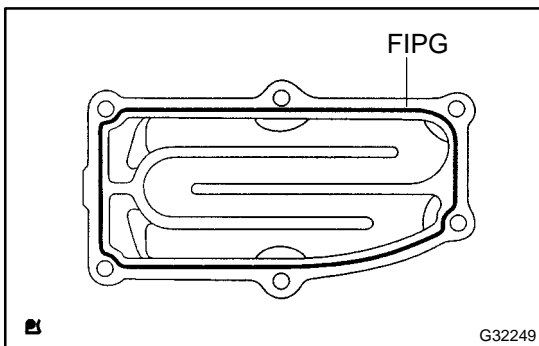
**51. INSTALL MOTOR WATERJACKET COVER**

- (a) Apply seal packing black in a continuous line of beads (diameter 1.5 mm, 0.06 in) as shown in the illustration.

**NOTICE:**

- **Clean and degrease the installation surfaces.**
- **Install within 10 minutes of applying seal packing.**

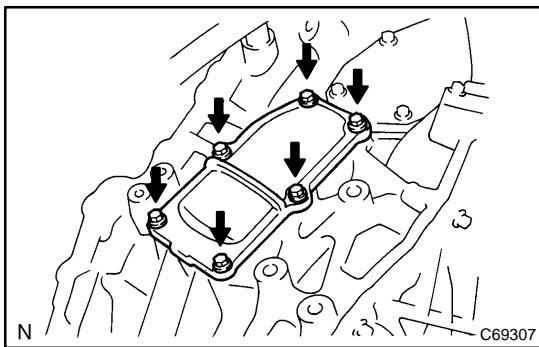

- (b) Apply liquid sealant 1344 to the first 2 to 3 threads of each of the 6 bolts. Install the motor water jacket cover with the 6 bolts.

**Torque: 5.5 N·m (56 kgf·cm, 49 in.-lbf)**

**NOTICE:**

**Clean and degrease the bolt and bolt holes.**

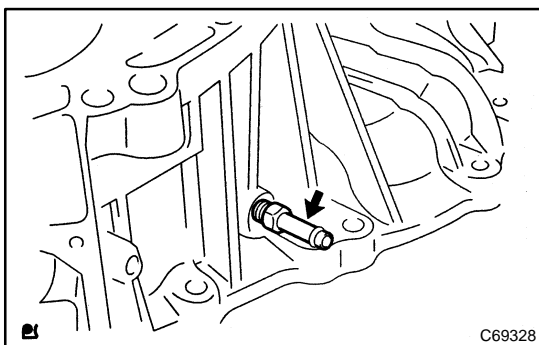
**52. INSTALL TRANSAXLE HOUSING TUBE CONNECTOR**

- (a) Apply liquid sealant 1344 to the first 2 to 3 threads of the bolt and install.

**Torque: 15 N·m (155 kgf·cm, 11 ft.-lbf)**

**NOTICE:**

**Clean and degrease the bolt and bolt holes.**

- (b) Install the drain plug using a new gasket.

**Torque: 39 N·m (400 kgf·cm, 29 ft.-lbf)**



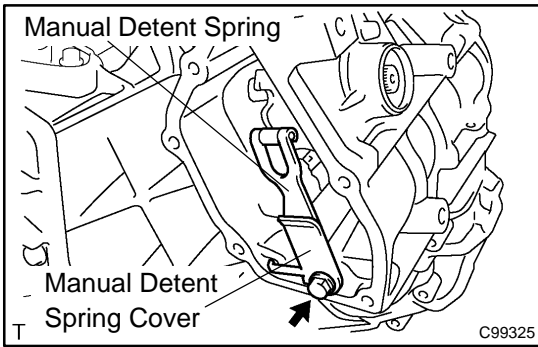

- 53. INSTALL MANUAL DETENT SPRING SUB-ASSY**  
 (a) Install the manual detent spring and manual detent spring cover using the blot.  
**Torque: 9.8 N·m (100 kgf·cm, 86 in.-lbf)**

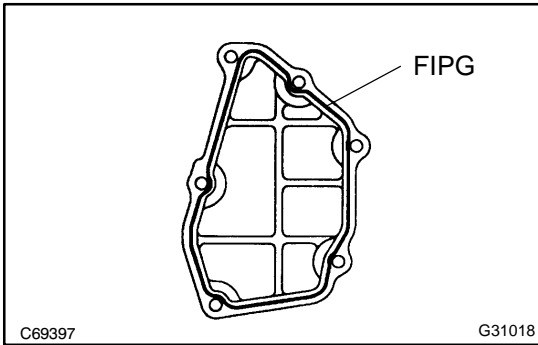

- 54. INSTALL PARKING COVER**  
 (a) Apply seal packing 1281 in a continuous line of beads (diameter 1.5 mm, 0.06 in) as shown in the illustration.

**NOTICE:**

- **Clean and degrease the installation surfaces.**
- **Install within 10 minutes of applying seal packing.**

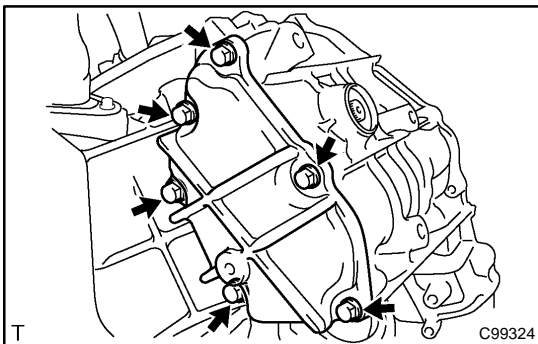

- (b) Install the parking cover with the 6 bolts.  
**Torque: 5.5 N·m (56 kgf·cm, 49 in.-lbf)**

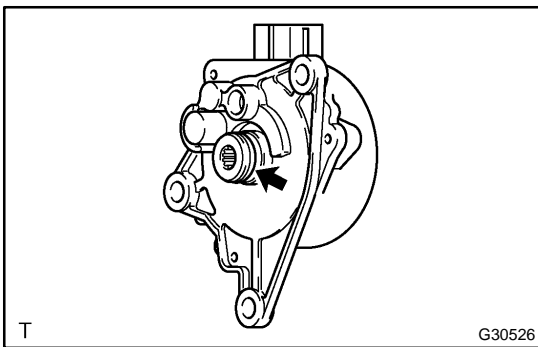

- 55. SHIFT CONTROL ACTUATOR ASSY**  
 (a) Apply a small amount of genuine ATF WS to the O-ring.

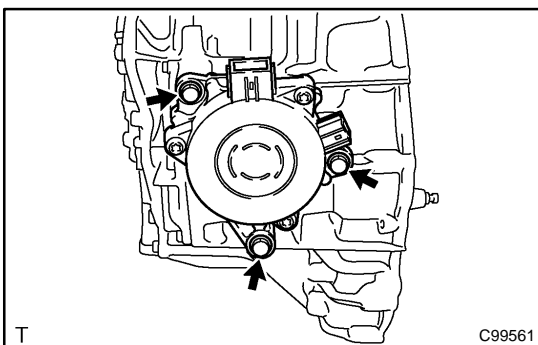

- (b) Install the shift control actuator with the 3 bolts.  
**Torque: 16 N·m (160 kgf·cm, 12 ft.-lbf)**  
 (c) Install the transmission case cover with the 3 bolts.

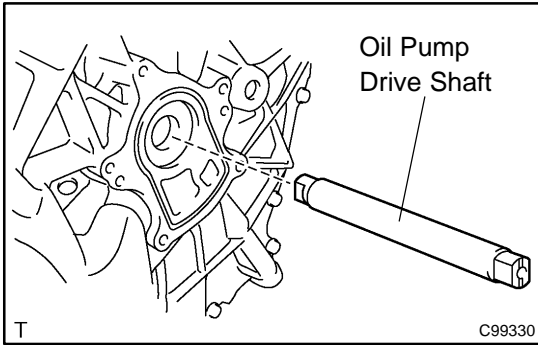

**56. INSTALL OIL PUMP DRIVE SHAFT**

- (a) Apply ATF WS to the fluid pump drive shaft and install.

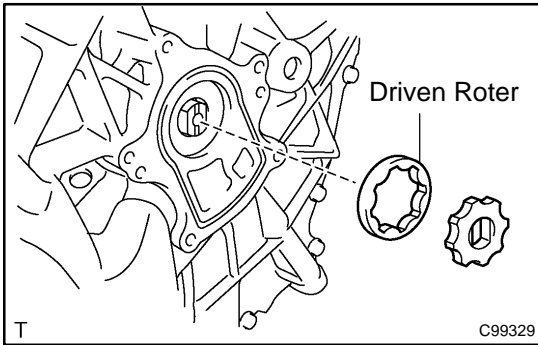

**57. INSTALL OIL PUMP DRIVEN ROTOR**

- (a) Apply ATF WS to the fluid pump driven rotor and install.

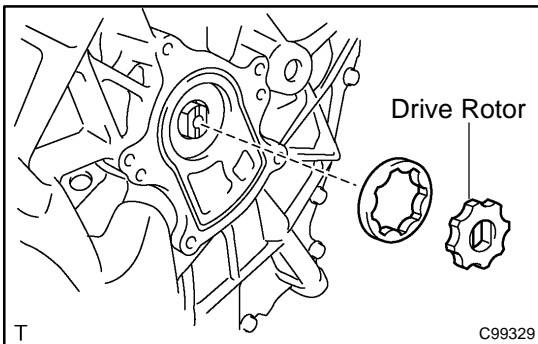

**58. INSTALL TRANSAXLE OIL PUMP DRIVE ROTOR**

- (a) Apply ATF WS to the transaxle fluid pump drive rotor and install.

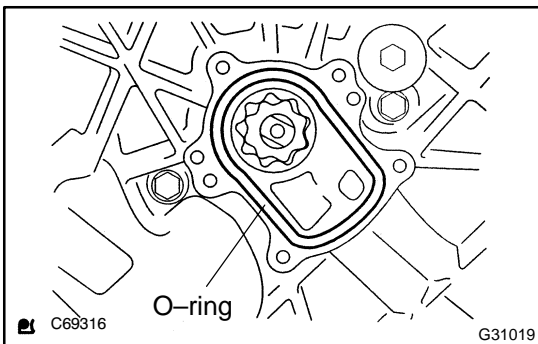

**59. INSTALL TRANSMISSION OIL PUMP COVER SUB-ASSY**

- (a) Install a new O-ring.

**NOTICE:**

**Ensure that the O-ring is not twisted.**

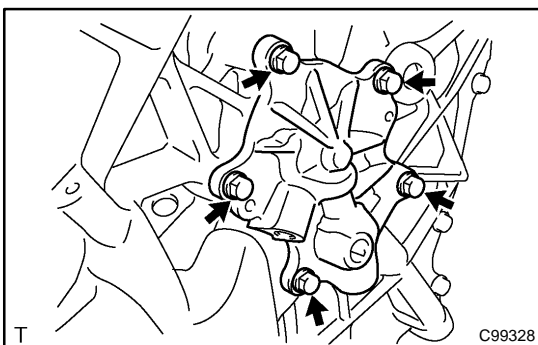

- (b) Apply liquid sealant 1344 to the first 2 to 3 threads of the bolt end.

**NOTICE:**

**Clean and degrease the bolts and bolt holes.**

- (c) Install the oil pump cover with the 5 bolts.

**Torque: 5.5 N·m (56 kgf·cm, 49 in·lbf)**

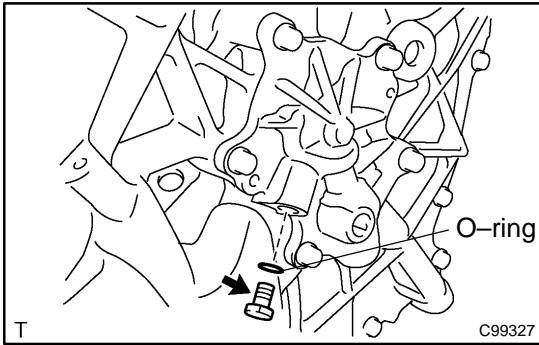

- (d) Install a new O-ring and install the fluid pump cover plug.  
**Torque: 7.4 N·m (75 kgf·cm, 65 in.-lbf)**

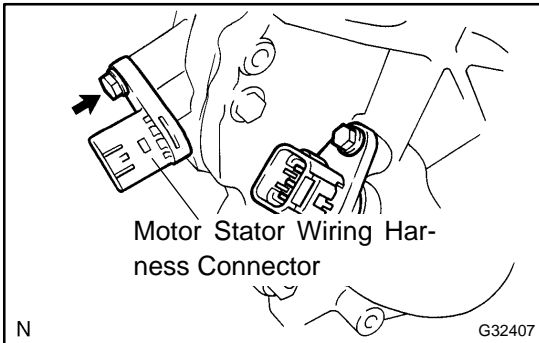

**60. INSTALL MOTOR STATOR WIRING HARNESS CONNECTOR**

- (a) Apply ATF WS to the O-ring and install the motor stator wiring harness connectors (black) with the bolt.  
**Torque: 5.8 N·m (59 kgf·cm, 51 in.-lbf)**

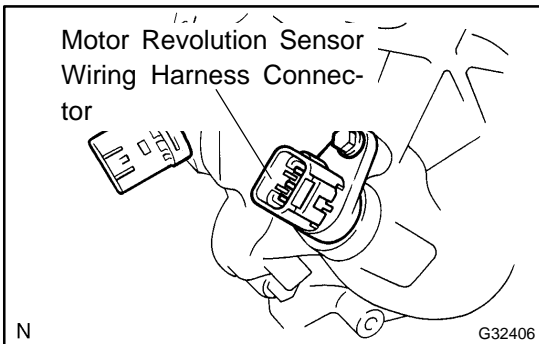

**61. INSTALL MOTOR REVOLUTION SENSOR WIRING HARNESS CONNECTOR**

- (a) Apply ATF WS to the O-ring and install the HV motor side motor revolution sensor wiring harness connectors (gray) with the bolt.  
**Torque: 5.8 N·m (59 kgf·cm, 51 in.-lbf)**

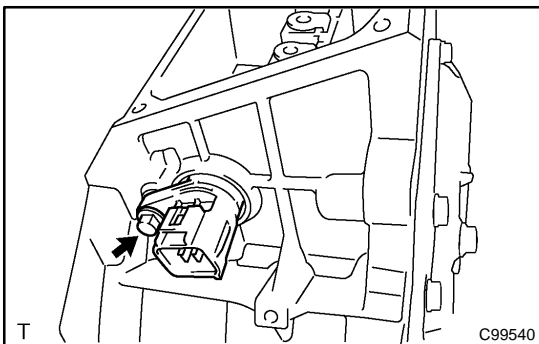

**62. INSTALL GENERATOR MOTOR REVOLUTION SENSOR WIRING HARNESS CONNECTOR**

- (a) Apply ATF WS to the O-ring and install the HV generator side generator motor revolution sensor wiring harness connector with the bolt.  
**Torque: 5.8 N·m (59 kgf·cm, 51 in.-lbf)**

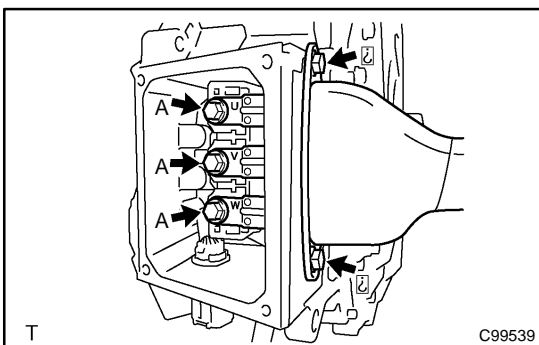

**63. INSTALL GENERATOR CABLE**

- (a) Align the generator cables as shown in the illustration and connect.

**NOTICE:**

- **Connect by aligning the letters U, V and W.**
  - **Apply a small amount of ATF WS to the O-ring.**
- (b) Apply liquid sealant to the first 2 or 3 threads of bolts B and install the generator cable with the bolts.  
**Torque: 5.8 N·m (59 kgf·cm, 51 in.-lbf) (bolt B)**

**NOTICE:**

**Clean and degrease the bolts and bolt holes.**

- (c) Install the generator cable with the 3 bolts (A).

**Torque: 8.5 N·m (87 kgf·cm, 75 in.-lbf) (bolt A)**

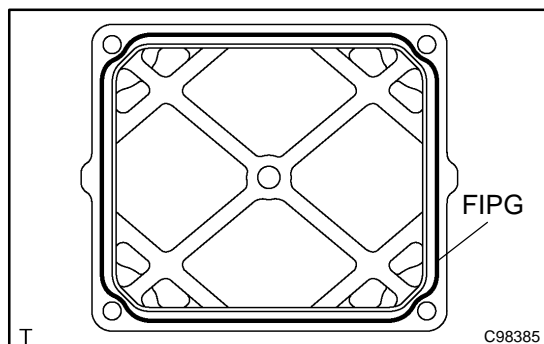
**64. INSTALL POWER CABLE COVER**

- (a) Apply seal packing 1281 in a continuous line of beads (diameter 1.5 mm 0.06 in.) as shown in the illustration.

**NOTICE:**

- **Clean and degrease the installation surfaces.**
- **Install within 10 minutes of applying seal packing.**

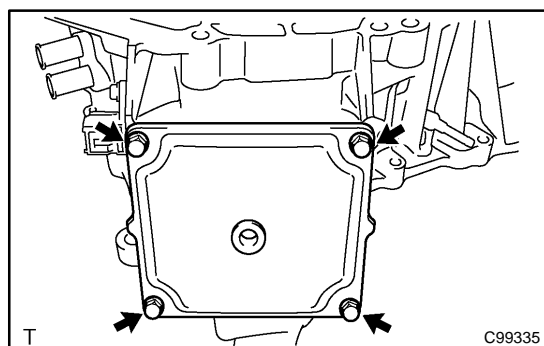

- (b) Apply liquid sealant 1344 to the first 2 or 3 threads of the 4 bolts and install the power cable cover.

**Torque: 4.8 N·m (49 kgf·cm, 42 in.-lbf)**

**NOTICE:**

**Clean and degrease the bolts and bolt holes.**

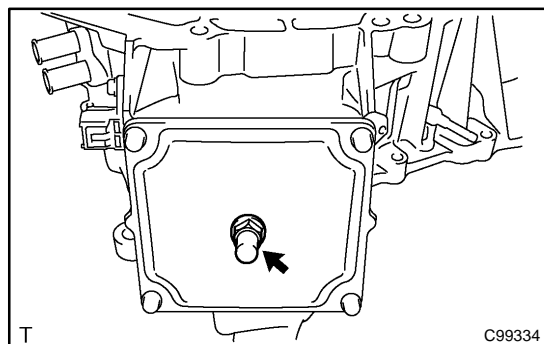

- (c) Install the breather plug.

**Torque: 11 N·m (112 kgf·cm, 8.1 ft.-lbf)**

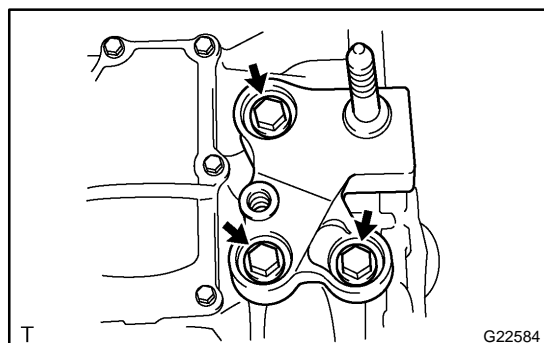
**65. INSTALL ENGINE MOUNTING BRACKET NO.3**

- (a) Apply liquid sealant 1344 to the first 2 or 3 threads of the 3 bolts and install the engine mounting bracket.

**Torque: 52 N·m (530 kgf·cm, 38 ft.-lbf)**

**NOTICE:**

**Clean and degrease the bolts and bolt holes.**

**66. INSTALL HYBRID VEHICLE TRANSAXLE ASSY (SEE PAGE 22-11)**