

REPLACEMENT

1. REMOVE REAR FLOOR BOARD NO.2 (See page 21-116)
2. REMOVE DECK FLOOR BOX REAR (See page 21-116)
3. REMOVE REAR FLOOR BOARD NO.3 (See page 21-116)
4. DISCONNECT BATTERY NEGATIVE TERMINAL (See page 21-116)
5. REMOVE RADIATOR SUPPORT OPENING COVER (See page 16-11)
6. REMOVE FRONT WHEEL RH
7. REMOVE ENGINE UNDER COVER LH
8. REMOVE ENGINE UNDER COVER RH
9. DRAIN ENGINE COOLANT (See page 16-11)
10. DRAIN ENGINE OIL
11. REMOVE WINDSHIELD WIPER LINK ASSY (See page 66-14)
12. REMOVE COWL TOP PANEL SUB-ASSY OUTER FRONT (See page 11-15)

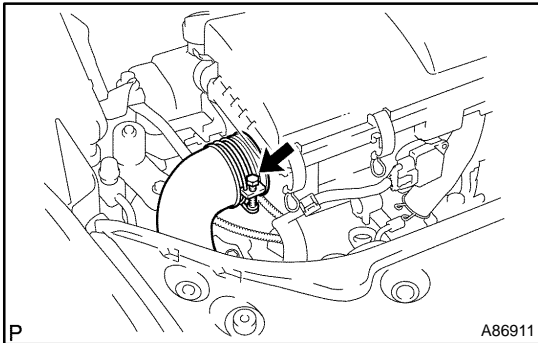

13. REMOVE AIR CLEANER ASSY

- (a) Loosen the clamp, then disconnect the air cleaner inlet No. 1 from the air cleaner case.

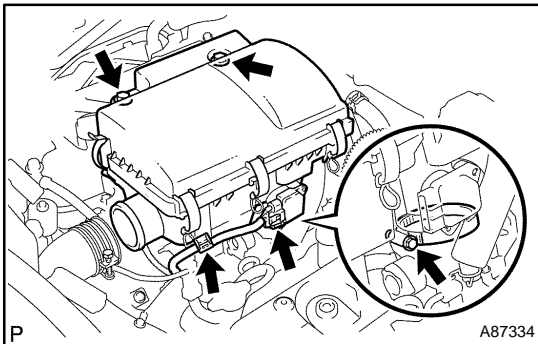

- (b) Disconnect the intake air flow meter connector, then remove the wire harness clamp.
- (c) Loosen the clamp, then remove the 2 bolts and air cleaner assembly.

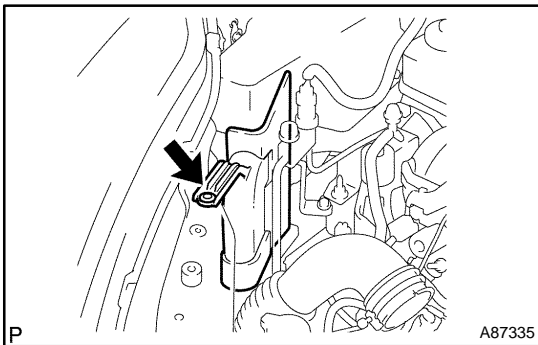

14. REMOVE AIR CLEANER INLET NO.2

- (a) Remove the clip and air cleaner inlet No. 2.

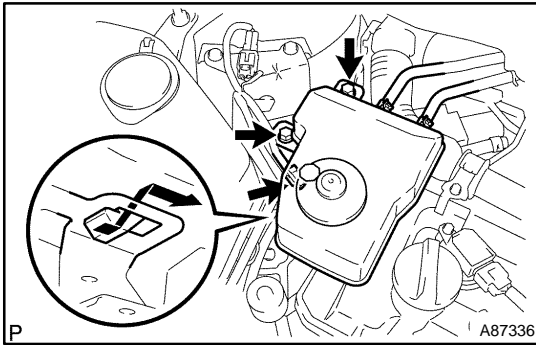

15. SUSPEND BRAKE MASTER CYLINDER RESERVOIR SUB-ASSY

- (a) Disconnect the connector.
- (b) Remove the 2 bolts.
- (c) Separate the claw fitting, then suspend the brake master cylinder reservoir with rope.

NOTICE:

Be careful of the angle of the brake master cylinder reservoir when suspending to prevent air from coming into the hose.

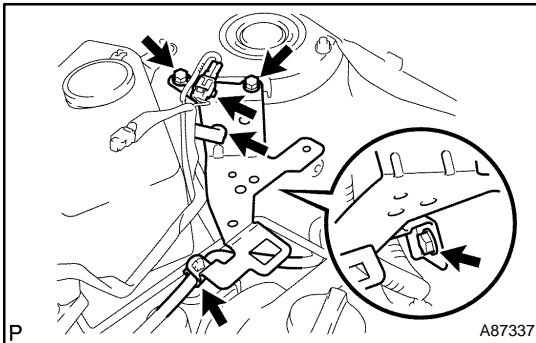

16. REMOVE RESERVOIR BRACKET

- (a) Disconnect the hose from the brake master cylinder reservoir bracket.
- (b) Remove the 3 bolts and wire harness clamp, then remove the brake master cylinder reservoir bracket.

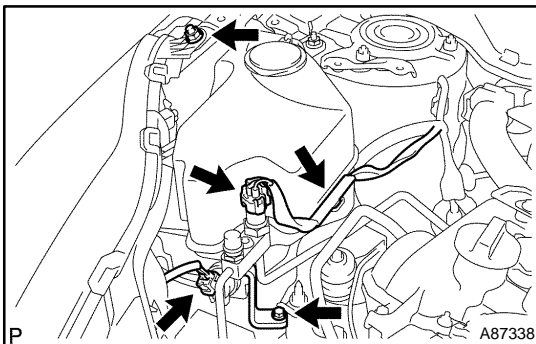

17. REMOVE WINDSHIELD WASHER JAR ASSY

- (a) Loosen the bolt which holds the head lamp RH.
- (b) Disconnect the connector and remove the wire harness clamp.
- (c) Remove the bolt and bracket.

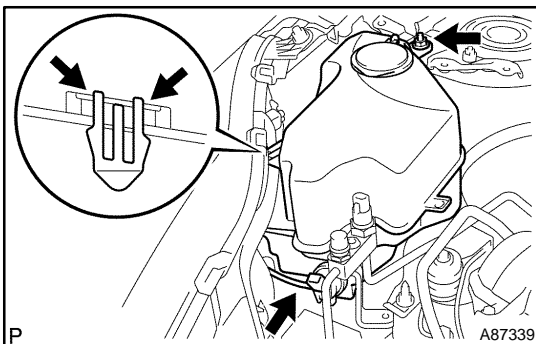

- (d) Remove the nut.
- (e) Slightly lift the head lamp RH and separate the claw fitting, then remove the washer jar assembly.
- (f) Disconnect the hose from the washer jar assembly.

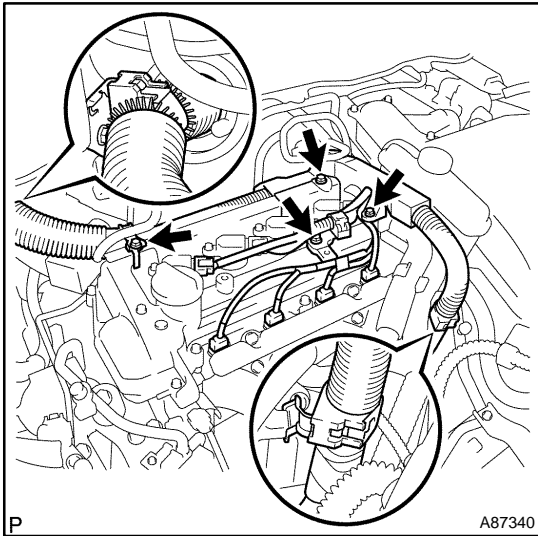

- 18. REMOVE CYLINDER HEAD COVER SUB-ASSY**
- (a) Disconnect the fuel injector connector and ignition coil connector.
 - (b) Remove the 3 bolts and wire harness clamp, then disconnect the wire harness.

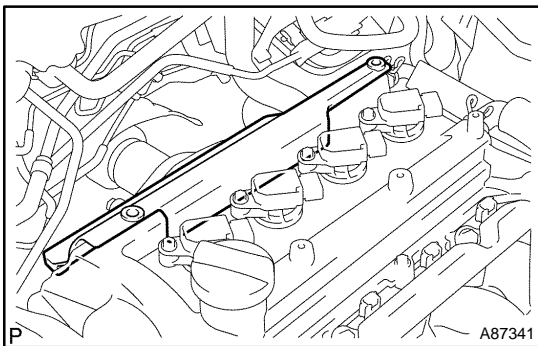

- (c) Remove the brake master cylinder reservoir cover.

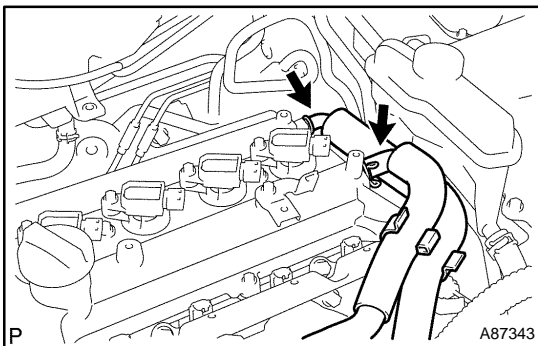

- (d) Disconnect the ventilation hose and ventilation hose No. 2.

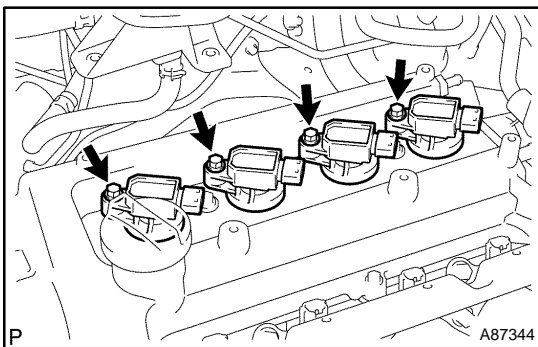

- (e) Remove the bolt and ignition coil.

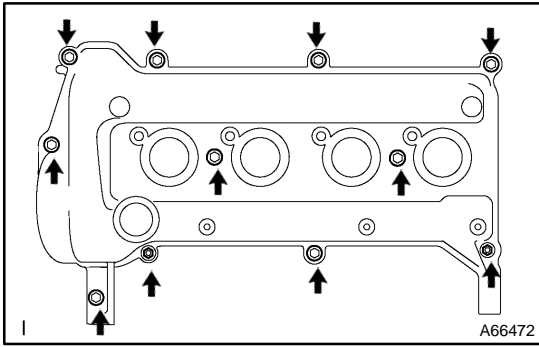

- (f) Remove the 9 bolts and 2 nuts, then remove the cylinder head cover.

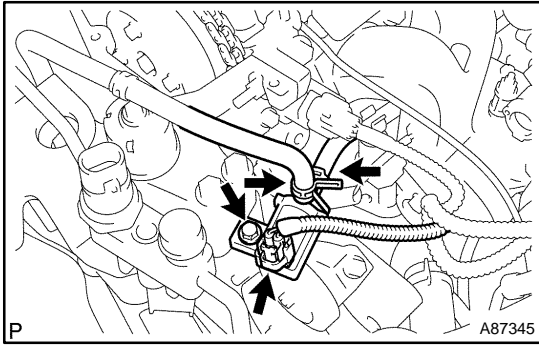

- 19. REMOVE VACUUM SWITCHING VALVE ASSY NO.2**
 (a) Disconnect the connector and hose.
 (b) Remove the bolt and vacuum switching valve assembly.

20. REMOVE FAN AND GENERATOR V BELT

21. REMOVE WATER PUMP ASSY

SST 09960-10010 (09962-01000, 09963-00600)

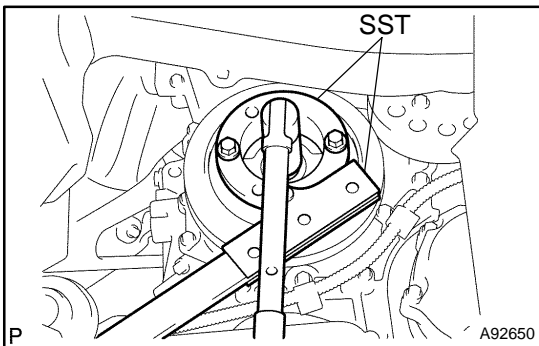

22. REMOVE CRANKSHAFT DAMPER SUB-ASSY

- (a) Using SST, hold the crankshaft damper and loosen the crankshaft bolt.
 SST 09213-58013 (91111-50845), 09330-00021

NOTICE:

When installing SST, be careful that the bolt which holds SST does not interfere with the chain cover.

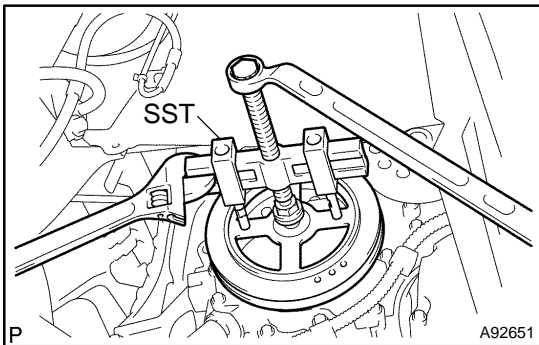

- (b) Loosen the crankshaft bolt until the 2 to 3 threads of the bolt is tightened to the crankshaft.
 (c) Using SST, remove the crankshaft damper.
 SST 09950-50013 (09951-05010, 09952-05010, 09953-05020, 09954-05021)
 (d) Remove the crankshaft bolt.

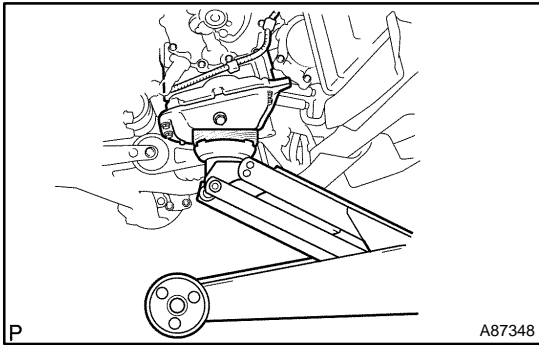

23. REMOVE ENGINE MOUNTING INSULATOR SUB-ASSY RH

(a) Put a wooden block on a jack underneath the oil pan to support the oil pan.

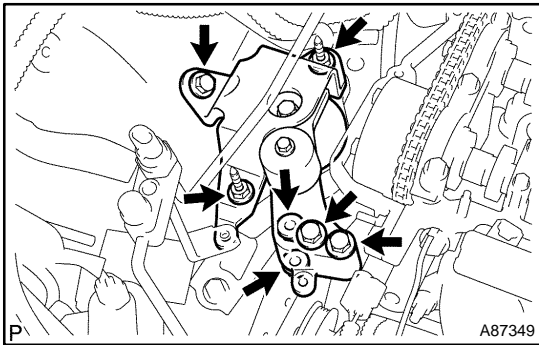

(b) Remove the 3 bolts and 4 nuts, then remove the engine mounting insulator RH.

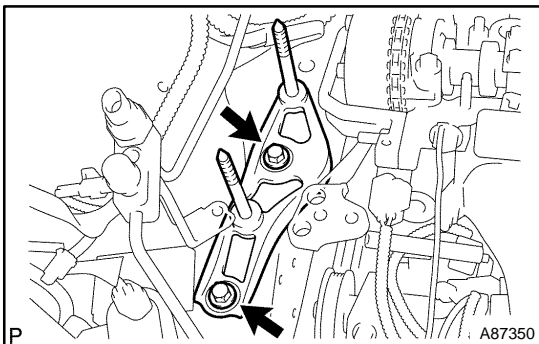

24. REMOVE ENGINE MOUNTING SPACER

(a) Remove the 2 bolts and engine mounting spacer.

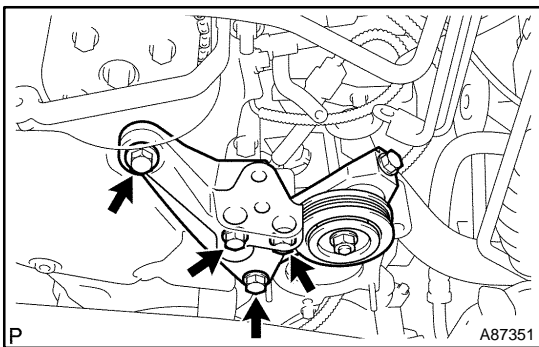

25. REMOVE TRANSVERSE ENGINE ENGINE MOUNTING BRACKET

(a) Remove the 4 bolts and engine mounting bracket.

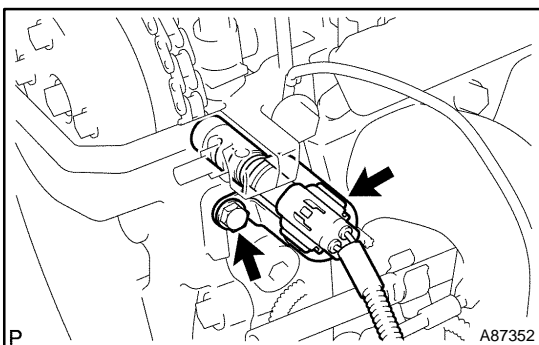

26. REMOVE CAMSHAFT TIMING OIL CONTROL VALVE ASSY

(a) Disconnect the connector.
 (b) Remove the bolt and camshaft timing oil control valve assembly.

27. REMOVE CRANK POSITION SENSOR (See page 18-10)

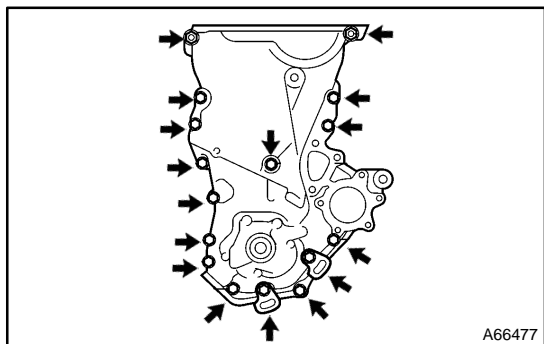

28. REMOVE OIL PUMP ASSY

(a) Remove the 15 bolts and nut.

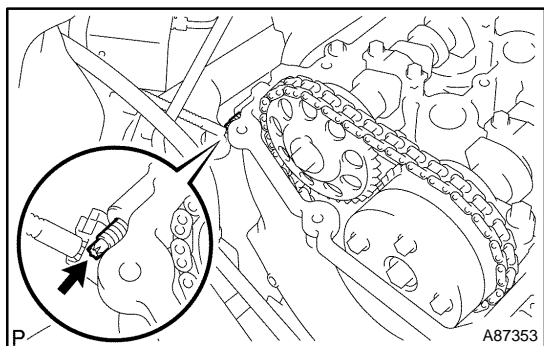

(b) Using a Torx socket wrench E8, remove the stud bolt.

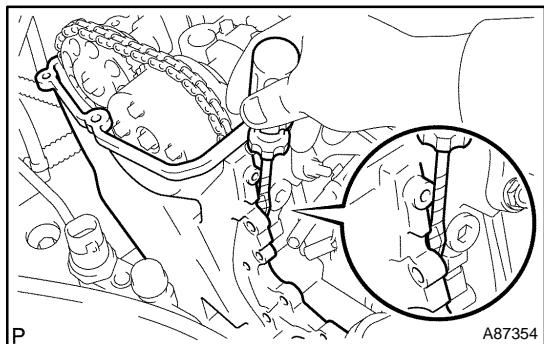

(c) Using a screwdriver with its tip wrapped in tape, remove the oil pump assembly by prying out between the cylinder head and cylinder block.

NOTICE:

Be careful not to damage the contact surfaces of the oil pump assembly, cylinder head and cylinder block.

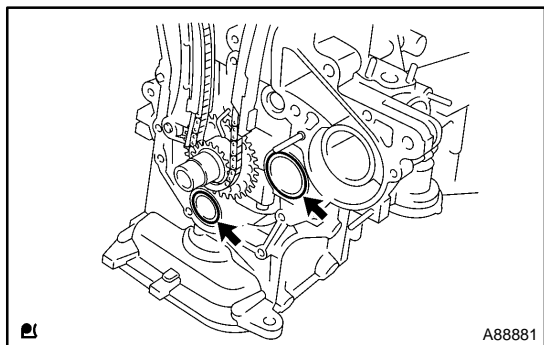

(d) Remove the 2 O-rings.

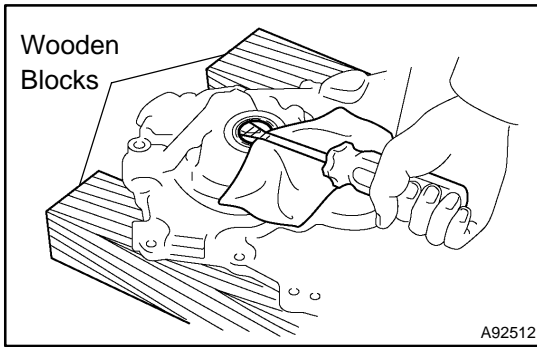
**29. REMOVE OIL PUMP SEAL**

- (a) Using a screwdriver with its tip wrapped in tape, remove the oil seal.

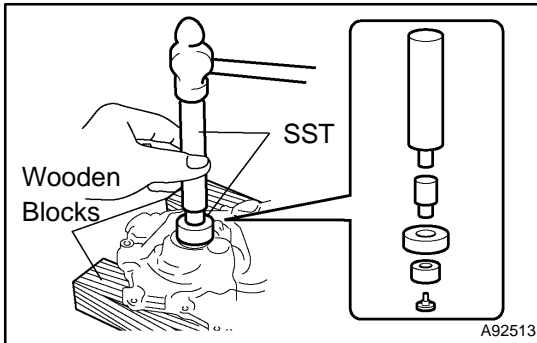
**30. INSTALL OIL PUMP SEAL**

- (a) Using SST, uniformly tap in a new oil seal until its surface is flush with the oil pump edge.

SST 09950-60010 (09951-00250, 09951-00380, 09952-06010), 09950-70010 (09951-07100)

HINT:

Be careful not to tap the oil seal at an angle.

- (b) Apply a light coat of multipurpose grease No. 2 to the lip of the new oil seal.

NOTICE:

Keep the lip free of foreign objects.

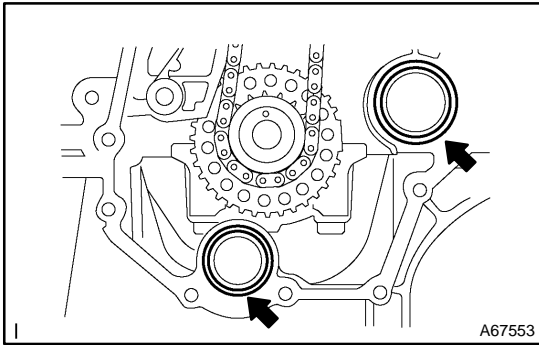

31. INSTALL OIL PUMP ASSY

- (a) Install 2 new O-rings to the 2 locations as shown in the illustration.
- (b) Apply seal packing to the engine body and oil pump as shown in the illustration below.

Seal packing:

Water pump part part No. 08826-00100 or equivalent

Other part part No. 08826-00080 or equivalent

NOTICE:

- Remove pump any oil from the contact surface.
- Install the oil pump within 3 minutes, and tighten the bolts within 15 minutes after applying seal packing.
- Do not expose the seal packing to engine oil within 2 hours of installation.

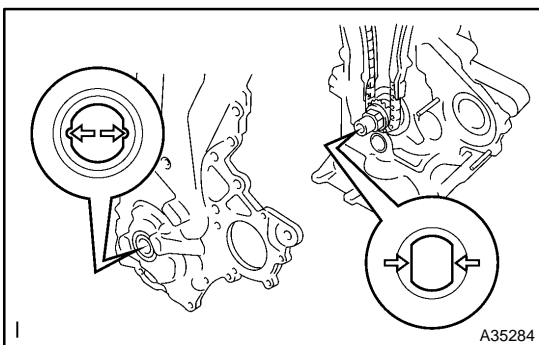
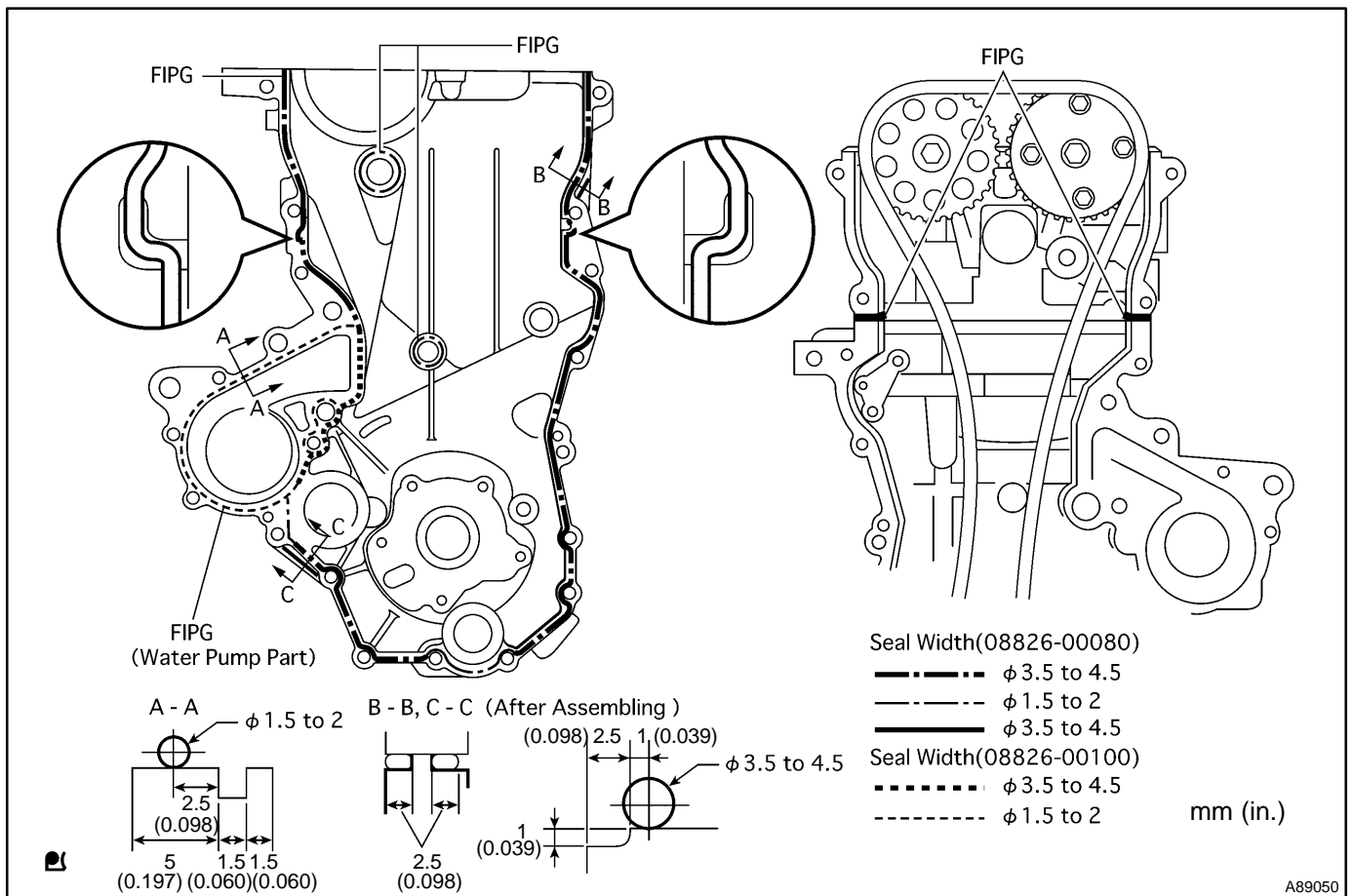

- (c) Align the drive rotor spline of the oil pump with the rectangular portion of the crankshaft, then slide the oil pump assembly into place.

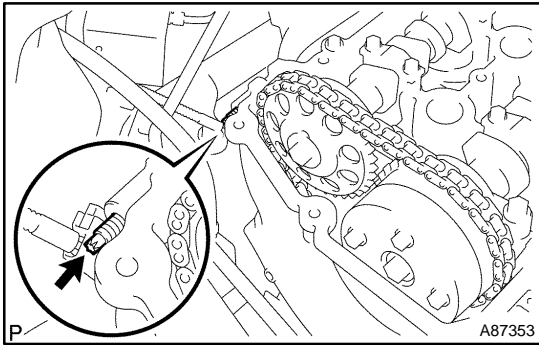

- (d) Using a Torx socket wrench E8, install the stud bolt.
Torque: 10 N·m (102 kgf·cm, 7.4 ft·lbf)

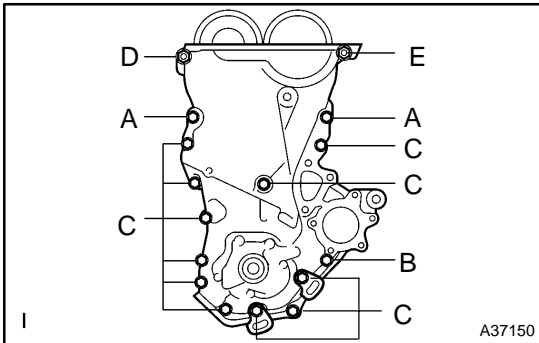

- (e) Install the oil pump assembly with the 15 bolts and nut as illustrated.
Torque:
32 N·m (326 kgf·cm, 24 ft·lbf) for bolt A
11 N·m (112 kgf·cm, 8.1 ft·lbf) for bolt B
11 N·m (112 kgf·cm, 8.1 ft·lbf) for bolt C
24 N·m (245 kgf·cm, 18 ft·lbf) for nut D
24 N·m (245 kgf·cm, 18 ft·lbf) for bolt E

NOTICE:

- Be careful that the chain does not contact the seal packing when installing the oil pump assembly.
- Install the engine mounting bracket RH and water pump assembly within 15 minutes after installing the oil pump assembly.

32. INSTALL CRANK POSITION SENSOR (See page 18-10)

33. INSTALL CAMSHAFT TIMING OIL CONTROL VALVE ASSY

- (a) Apply a light coat of engine oil to the O-ring.
- (b) Install the camshaft timing oil control valve assembly with the bolt.
Torque: 7.5 N·m (76 kgf·cm, 66 in·lbf)

34. INSTALL TRANSVERSE ENGINE ENGINE MOUNTING BRACKET

Torque: 55 N·m (561 kgf·cm, 41 ft·lbf)

35. INSTALL ENGINE MOUNTING SPACER

Torque: 52 N·m (530 kgf·cm, 38 ft·lbf)

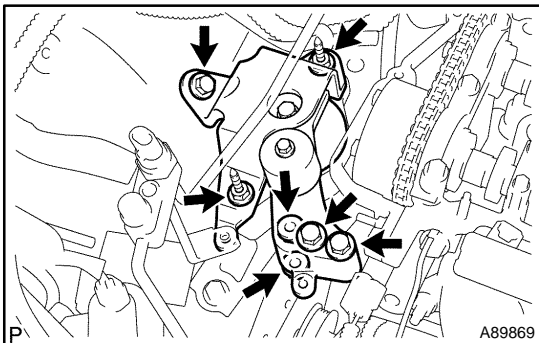

36. INSTALL ENGINE MOUNTING INSULATOR SUB-ASSY RH

- (a) Install the engine mounting insulator RH with the 3 bolts and 4 nuts.
Torque: 52 N·m (530 kgf·cm, 38 ft·lbf)

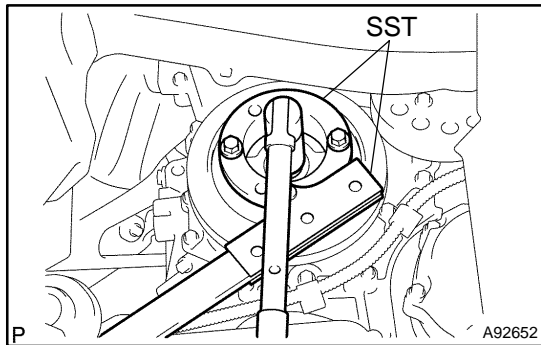
**37. INSTALL CRANKSHAFT DAMPER SUB-ASSY**

- (a) Align the hole of the crankshaft damper with the straight pin, then install the crankshaft damper.
- (b) Using SST, hold the crankshaft damper and tighten the crankshaft bolt.

SST 09213-58013 (91111-50845), 09330-00021

Torque: 128 N·m (1305 kgf·cm, 95 ft·lbf)

NOTICE:

When installing SST, be careful that the bolt which holds SST does not interfere with the chain cover.

38. INSTALL WATER PUMP ASSY (See page 16-15)

SST 09960-10010 (09962-01000, 09963-00600)

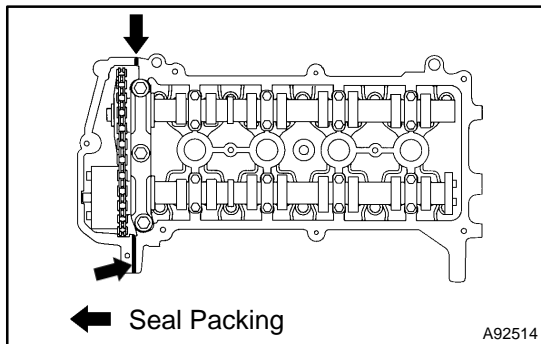
39. INSTALL FAN AND GENERATOR V BELT (See page 14-5)**40. INSPECT DRIVE BELT DEFLECTION AND TENSION (See page 14-1)****41. INSTALL VACUUM SWITCHING VALVE ASSY NO.2****42. INSTALL CYLINDER HEAD COVER SUB-ASSY**

- (a) Apply seal packing to the 2 locations as shown in the illustration, then install the cylinder head cover.

Seal packing: Part No. 08826-00080 or equivalent

NOTICE:

- Remove any oil from the contact surface.
- Install the cylinder head cover within 3 minutes after applying seal packing.
- Do not start the engine within 2 hours of installing.

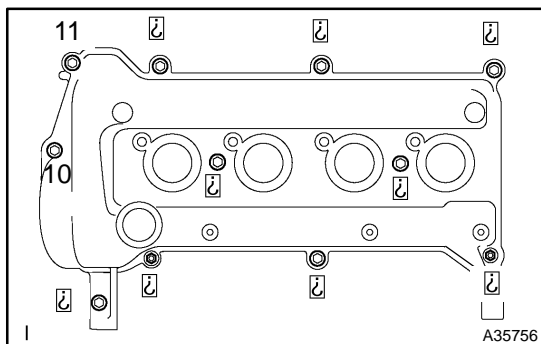

- (b) Install the cylinder head cover with the 9 bolts and 2 nuts.

- (c) Using several steps, tighten the bolts and nuts with the specified torque in the sequence shown in the illustration.

Torque: 10 N·m (102 kgf·cm, 74 ft·lbf)

- (d) Install the ignition coil with the bolt.

Torque: 9.0 N·m (92 kgf·cm, 80 in·lbf)

- (e) Install the brake master cylinder reservoir cover to the cylinder head cover.

- (f) Install the wire harness and brake master cylinder reservoir cover with the 3 bolts.

Torque: 9.0 N·m (92 kgf·cm, 80 in·lbf)

- (g) Connect the fuel injector connector and ignition coil connector.

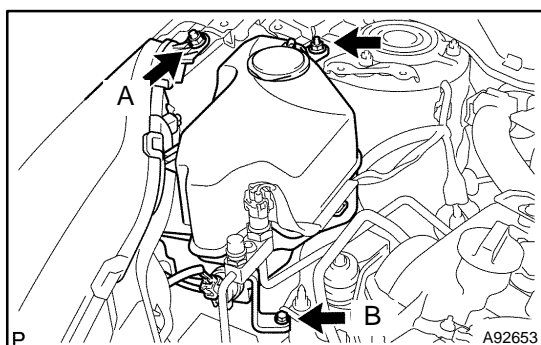
**43. INSTALL WINDSHIELD WASHER JAR ASSY**

Torque:

4.9 N·m (50 kgf·cm, 43 in·lbf) for bolt A

14 N·m (143 kgf·cm, 10 ft·lbf) for bolt B

5.5 N·m (56 kgf·cm, 49 in·lbf) for nut

44. **INSTALL RESERVOIR BRACKET**
Torque: 8.5 N·m (87 kgf·cm, 75 in·lbf)
45. **INSTALL BRAKE MASTER CYLINDER RESERVOIR SUB-ASSY**
Torque: 8.5 N·m (87 kgf·cm, 75 in·lbf)
46. **INSTALL AIR CLEANER INLET NO.2**
47. **INSTALL AIR CLEANER ASSY**
Torque:
7.0 N·m (71 kgf·cm, 62 in·lbf) for Bolt
3.0 N·m (31 kgf·cm, 27 in·lbf) for Clamp
48. **INSTALL COWL TOP PANEL SUB-ASSY OUTER FRONT (See page 11-15)**
49. **INSTALL WINDSHIELD WIPER LINK ASSY (See page 66-14)**
50. **ADD ENGINE OIL (See page 17-21)**
51. **CONNECT BATTERY NEGATIVE TERMINAL**
Torque: 6.0 N·m (61 kgf·cm, 53 in·lbf)
52. **INSTALL REAR FLOOR BOARD NO.3**
53. **INSTALL DECK FLOOR BOX REAR**
54. **INSTALL REAR FLOOR BOARD NO.2**
55. **ADD ENGINE COOLANT (See page 16-11)**
56. **CHECK FOR ENGINE COOLANT LEAKS (See page 16-2)**
57. **INSPECT ENGINE OIL LEAKS**
58. **INSTALL RADIATOR SUPPORT OPENING COVER**
59. **INSTALL ENGINE UNDER COVER RH**
60. **INSTALL ENGINE UNDER COVER LH**
61. **INSTALL FRONT WHEEL RH**
Torque: 103 N·m (1050 kgf·cm, 76 ft·lbf)
62. **POWER WINDOW CONTROL SYSTEM INITIALIZE (See page 01-28)**