

SMART UNLOCK FUNCTION DOES NOT OPERATE ON PASSENGER DOOR

CIRCUIT DESCRIPTION

When an ID code from the passenger door outside oscillator matches an ID code from the smart key, the smart ECU outputs a SEL signal (Lo when output) to the front passenger door outside oscillator, activates the touch sensor inside the outside handle, and enters unlock standby condition. When the touch sensor is touched, the outside oscillator sends a SENS signal (Lo when output) to the smart ECU and the smart ECU sends an unlock signal to the passenger door lock assembly.

WIRING DIAGRAM

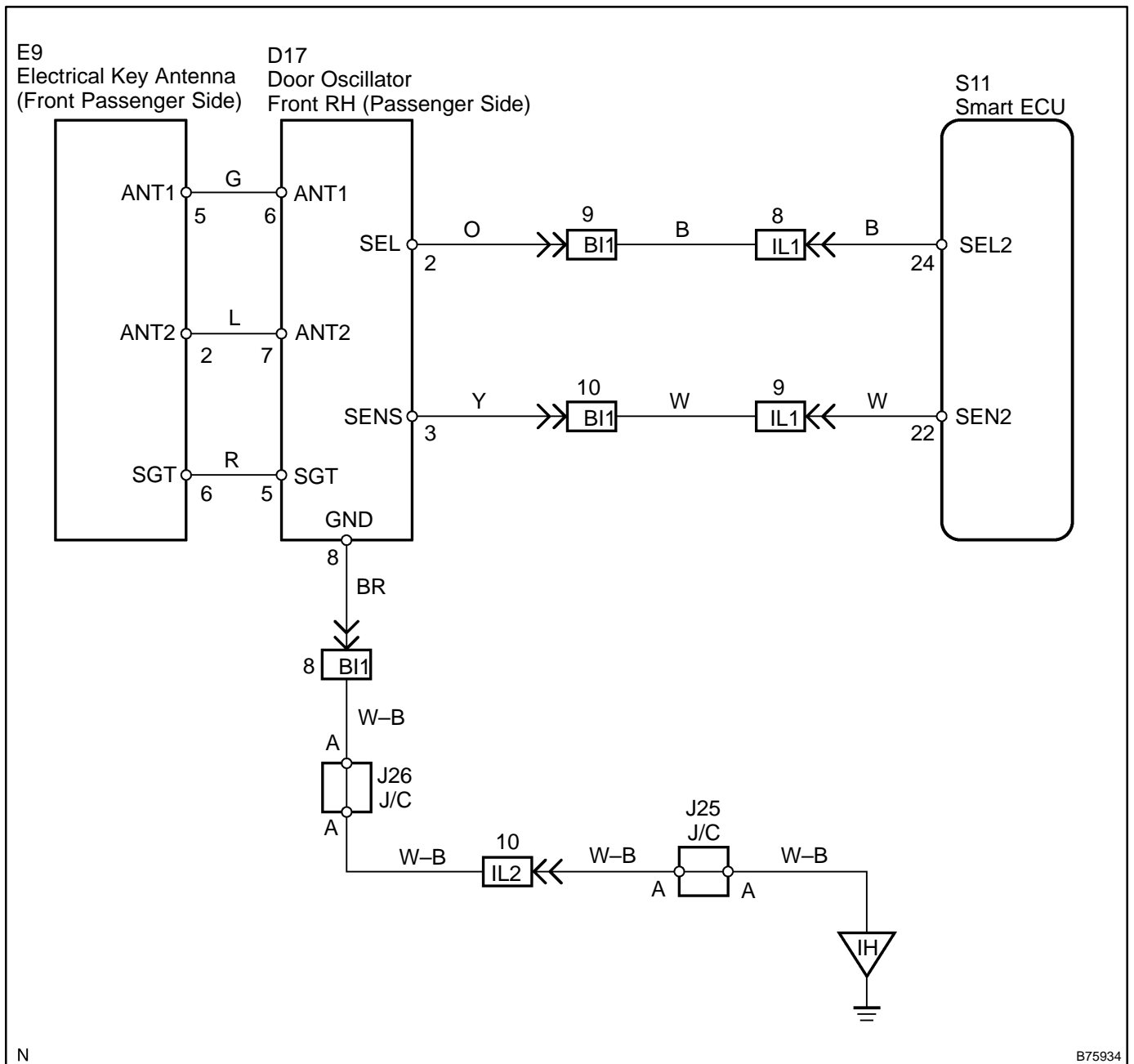

N

B75934

INSPECTION PROCEDURE

1 CHECK MANUAL DOOR UNLOCK OPERATION

(a) Check that the manual door unlock function operates normally.

OK: Manual door unlock function operates normally.

NG Go to **POWER DOOR LOCK CONTROL SYSTEM**
(See page [05-2074](#))

OK

2 CHECK DOOR OSCILLATOR (FRONT PASSENGER SIDE)

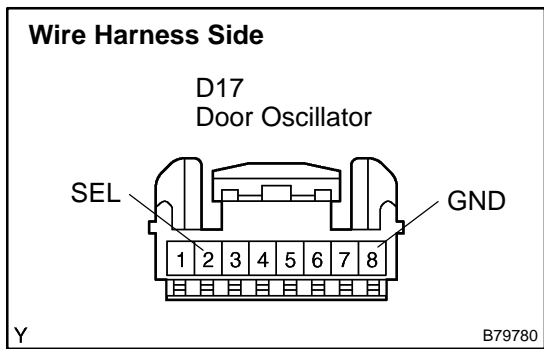

(a) Measure the voltage between the terminals of the connector when the smart key is operated.

Standard:

Tester Connection	Condition	Specified Condition
D17-2 (SEL) – D17-8 (GND)	Smart key at least 5 m away from door → near door	10 to 14 V → Below 1 Ω

NG Go to step 7

OK

3 CHECK DOOR OSCILLATOR (FRONT PASSENGER SIDE)

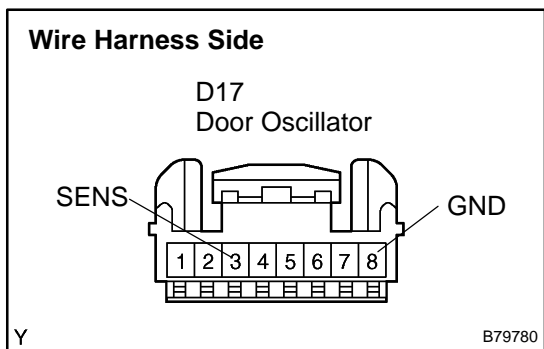

(a) Measure the voltage between the terminals of the connector when the outside door handle is touched.

Standard:

Tester Connection	Condition	Specified Condition
D17-3 (SENS) – D17-8 (GND)	Outside door handle not touched → touched	10 to 14 V → Below 1 Ω

NG Go to step 4

OK

Go to step 5

4 CHECK WIRE HARNESS (DOOR OSCILLATOR (FRONT PASSENGER SIDE) – SMART ECU AND BODY GROUND)

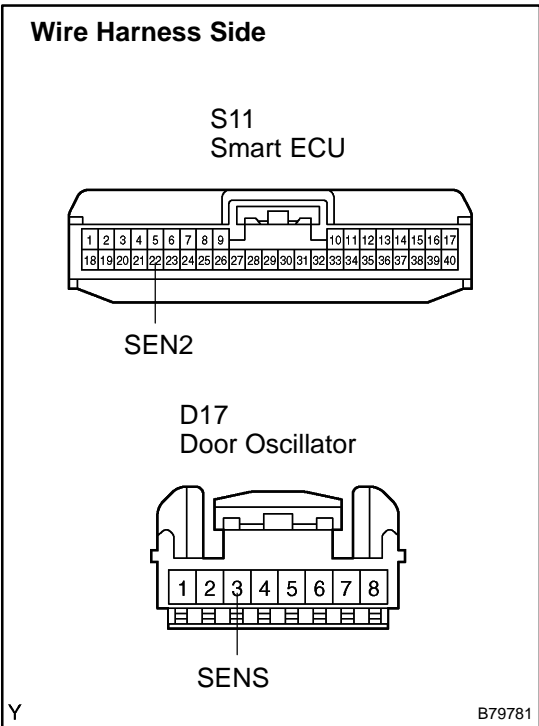

- (a) Disconnect the D17 oscillator connector.
- (b) Disconnect the S11 ECU connector.
- (c) Measure the resistance of the wire harness side connectors.

Standard:

Tester Connection	Specified Condition
D17-3 (SENS) – S11-22 (SEN2)	Below 1 Ω
D17-3 (SENS) – Body ground	10 kΩ or higher

NG REPAIR OR REPLACE HARNESS AND CONNECTOR

OK

5 CHECK OPERATION OF DOOR OSCILLATOR (FRONT PASSENGER SIDE)

- (a) After replacing the door oscillator with a new one, check that the smart unlock function operates normally.

OK: Smart unlock function operates normally.

NG Go to step 6

OK

REPLACE DOOR OSCILLATOR (FRONT PASSENGER SIDE)

6 CHECK WIRE HARNESS (DOOR OSCILLATOR (FRONT PASSENGER SIDE) – ELECTRICAL KEY ANTENNA AND BODY GROUND)

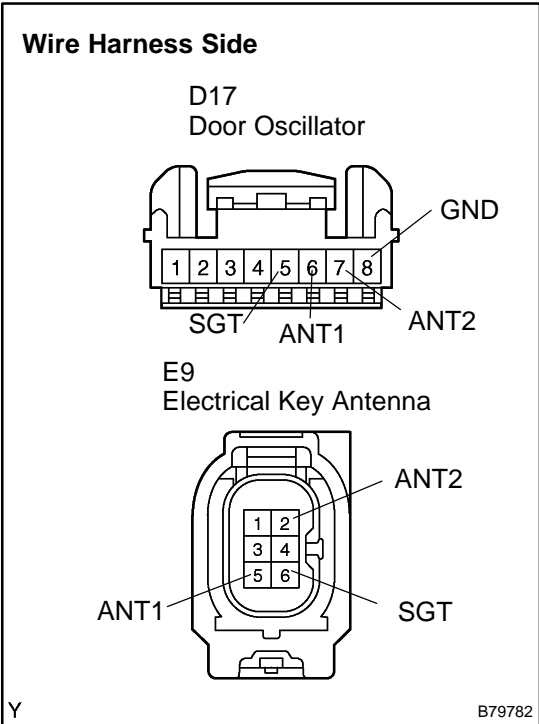

- (a) Disconnect the D17 oscillator connector.
- (b) Disconnect the E9 antenna connector.
- (c) Measure the resistance of the wire harness side connectors.

Standard:

Tester Connection	Specified Condition
D17-6 (ANT1) – E9-5 (ANT1)	Below 1 Ω
D17-7 (ANT2) – E9-2 (ANT2)	Below 1 Ω
D17-5 (SGT) – E9-6 (SGT)	Below 1 Ω
D17-8 (GND) – Body ground	Below 1 Ω
D17-6 (ANT1) – Body ground	10 kΩ or higher
D17-7 (ANT2) – Body ground	10 kΩ or higher
D17-5 (SGT) – Body ground	10 kΩ or higher

NG REPAIR OR REPLACE HARNESS AND CONNECTOR

OK

REPLACE ELECTRICAL KEY ANTENNA

7 CHECK WIRE HARNESS (DOOR OSCILLATOR (FRONT PASSENGER SIDE) – SMART ECU AND BODY GROUND)

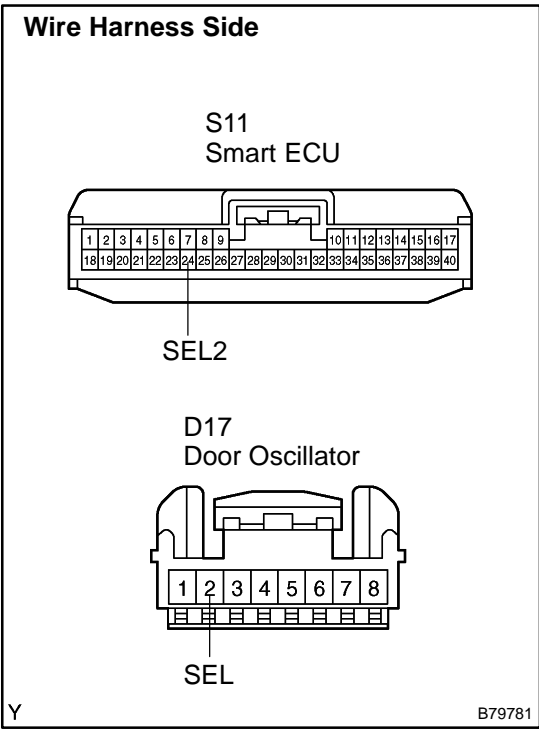

- (a) Disconnect the D17 oscillator connector.
- (b) Disconnect the S11 ECU connector.
- (c) Measure the resistance of the wire harness side connectors.

Standard:

Tester Connection	Specified Condition
D17-2 (SEL) – S11-24 (SEL2)	Below 1 Ω
D17-2 (SEL) – Body ground	10 kΩ or higher

NG REPAIR OR REPLACE HARNESS AND CONNECTOR

OK

REPLACE SMART ECU