

DTC	B2286	READY SIGNAL MALFUNCTION
------------	--------------	---------------------------------

CIRCUIT DESCRIPTION

The power source control ECU and the hybrid vehicle control ECU are connected by the cable and BEAN. If the cable information and BEAN information are inconsistent, this DTC will be output.

DTC No.	DTC Detection Condition	Trouble Area
B2286	Cable and BEAN information between power source control ECU and hybrid vehicle control ECU are inconsistent	<ul style="list-style-type: none"> • Power source control ECU • Hybrid vehicle control ECU • Wire harness

WIRING DIAGRAM

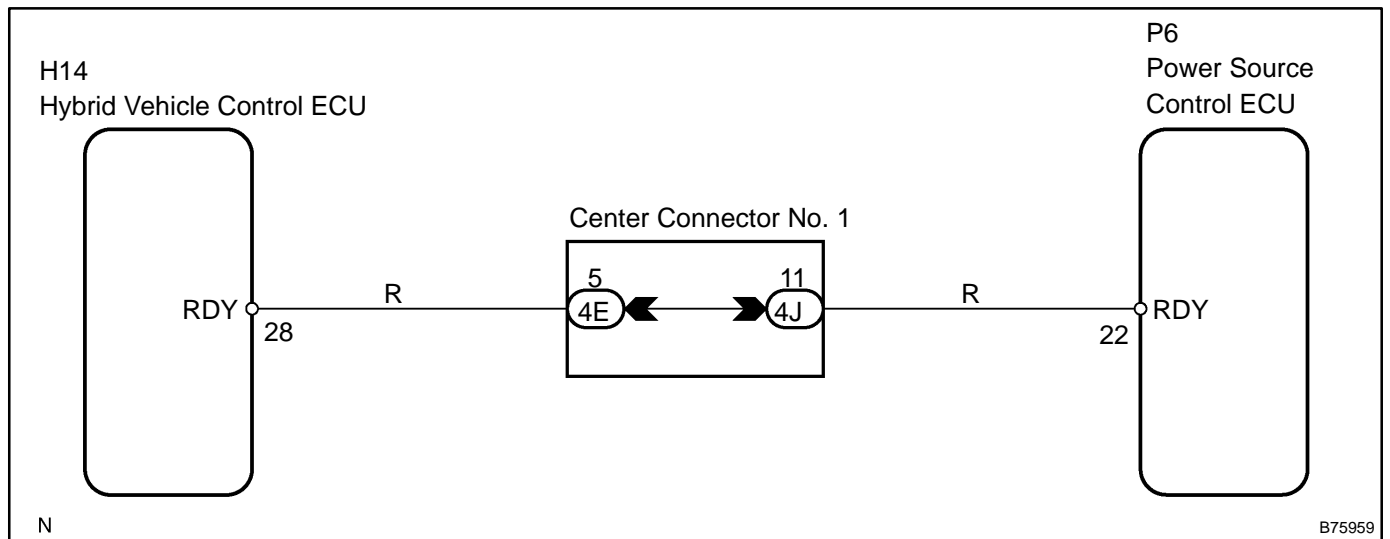

N

B75959

INSPECTION PROCEDURE

1 READ VALUE OF HAND-HELD TESTER

- (a) Connect the hand-held tester (with CAN VIM) to the DLC3.
- (b) Turn the power switch ON (IG) and press the hand-held tester main switch ON.
- (c) Read the DATA LIST according to the displays on the tester.

Standard (Power source control ECU):

Item	Measurement Item/Range (Display)	Normal Condition	Diagnostic Note
READY SIG	States of the Ready signal / ON or OFF	ON: Power switch ON (Ready) OFF Power switch OFF or ON (IG) or ON (ACC)	-

OK: "ON" (power switch is ON) appears on the screen.

NG Go to step 2

OK

REPLACE POWER SOURCE CONTROL ECU

2 CHECK WIRE HARNESS (POWER SOURCE CONTROL ECU - HYBRID VEHICLE CONTROL ECU)

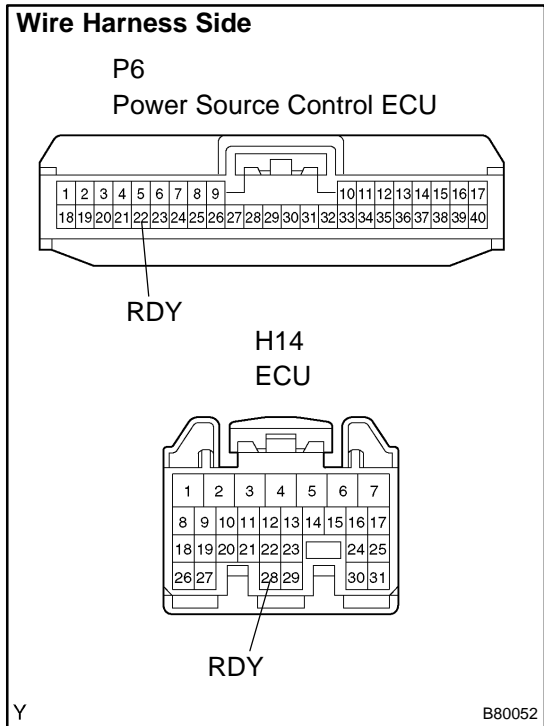

- (a) Disconnect the P6 and H14 ECU connectors.
- (b) Measure the resistance of the wire harness side connectors.

Standard:

Tester Connection	Specified Condition
P6-22 (RDY) - H14-28 (RDY)	Below 1 Ω
P6-22 (RDY) - Body ground	10 kΩ or higher

NG REPAIR OR REPLACE HARNESS AND CONNECTOR

OK

3 CHECK OPERATION OF POWER SOURCE CONTROL ECU

- (a) After replacing the power source control ECU with a normally functioning ECU, check that the hybrid vehicle control system can start normally.

OK: Hybrid vehicle control system can start normally.

NG

**Go to HYBRID CONTROL SYSTEM
(See page [05-385](#))**

OK

NORMAL (POWER SOURCE CONTROL ECU DEFECTIVE)