

BRAKE CONTROL WARNING LIGHT CIRCUIT (REMAINS ON)**CIRCUIT DESCRIPTION**

The skid control ECU is connected to the combination meter via CAN and Multiplex communications. Informs the driver when there is trouble with ECB or a problem with the brake system that has no influence on driving, by turning on.

WIRING DIAGRAM

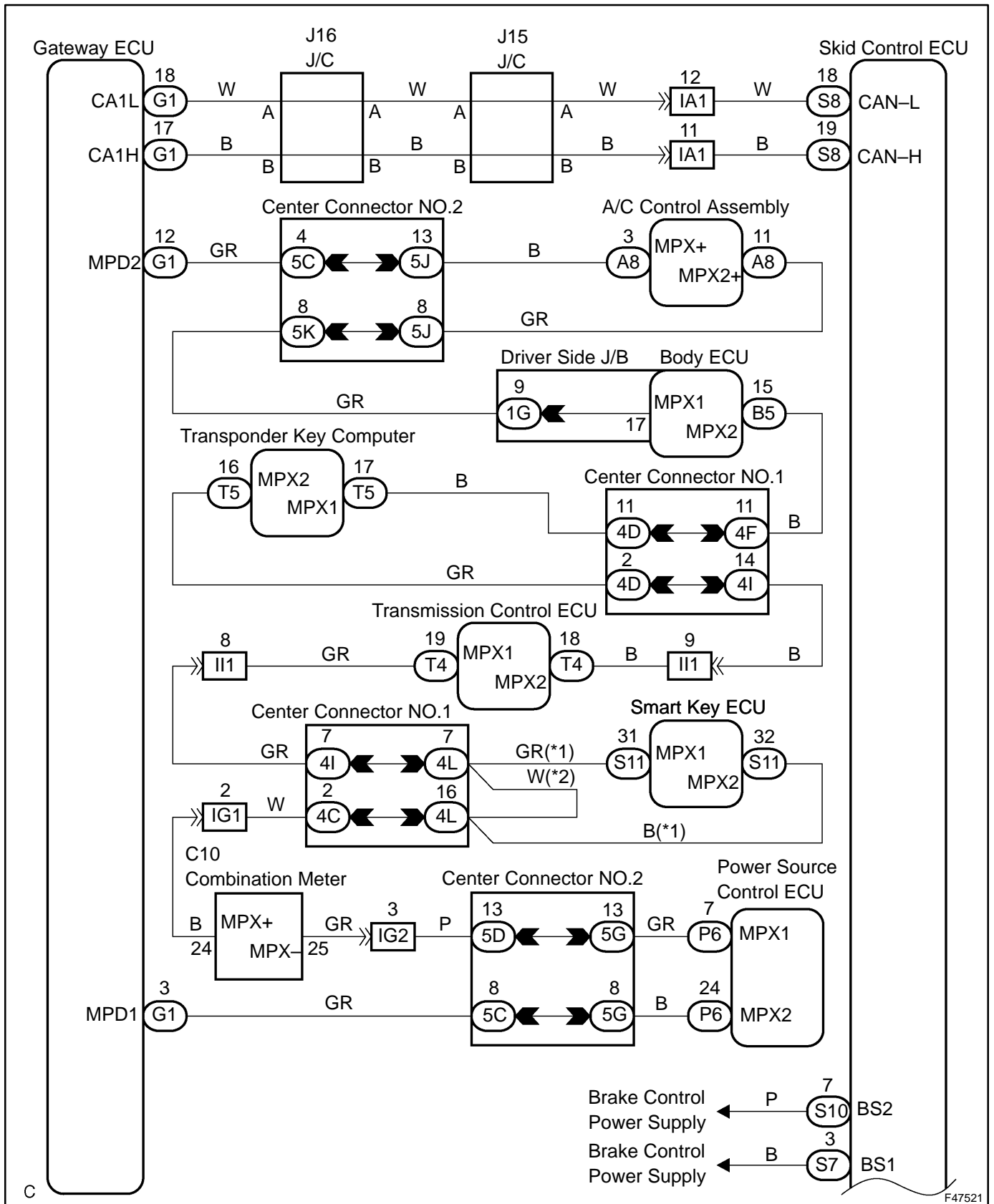

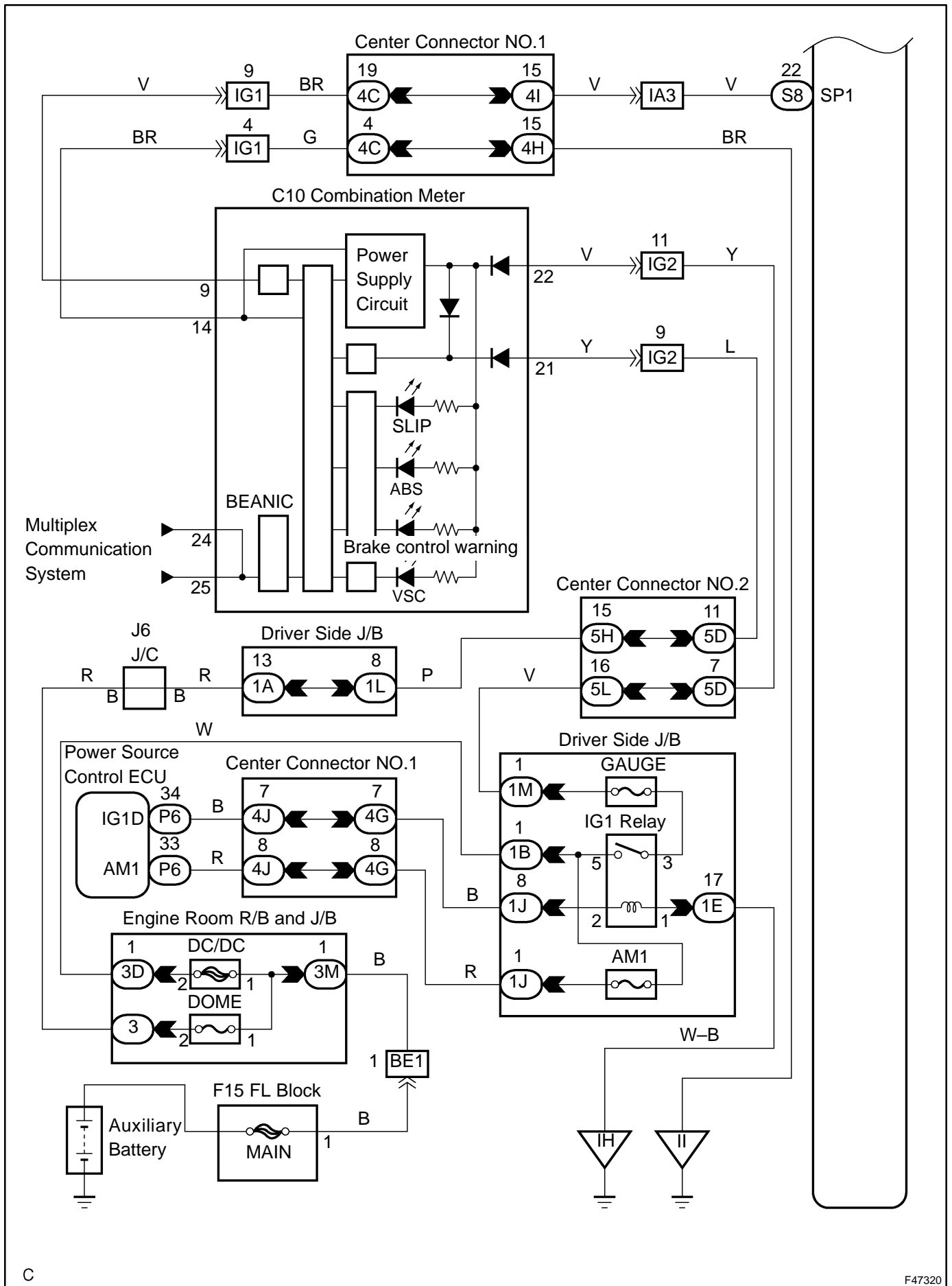

C

F47320

INSPECTION PROCEDURE

1 INSPECT SKID CONTROL ECU TERMINAL VOLTAGE (BS1, BS2)

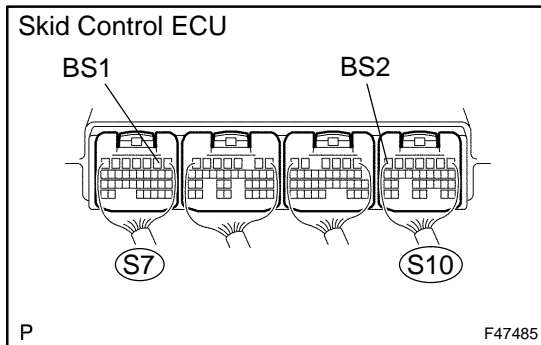

(a) Measure the voltage according to the value(s) in the table below.

HINT:

Measure the voltage from behind the connector with the connector connected to the skid control ECU.

Standard:

Tester Connection	Specified Condition
S7-3 (BS1) – Body ground	10 to 14 V
S10-7 (BS2) – Body ground	10 to 14 V

NG REPAIR OR REPLACE HARNESS OR CONNECTOR

OK

2 PERFORM ACTIVE TEST BY HAND-HELD TESTER (BRAKE CONTROL WARNING LIGHT)

- (a) Connect the hand-held tester to the DLC3.
- (b) Turn the power switch ON (READY).
- (c) Select the item "ECB INDI LIGHT" in the ACTIVE TEST and operate the Brake Control warning light on the hand-held tester.

Item	Vehicle Condition / Test Details	Diagnostic Note
ECB INDI LIGHT	Turns Brake Control warning light ON / OFF	Observe combination meter

- (d) Check that "ON" and "OFF" of the Brake Control warning light are indicated on the combination meter when using the hand-held tester.

OK:

The Brake Control warning light turns on or off in accordance with the hand-held tester.

NG REPAIR OR REPLACE COMBINATION METER ASSY (SEE PAGE 05-1986)

OK

REPLACE SKID CONTROL ECU ASSY (SEE PAGE 32-68)

NOTICE:

When replacing the skid control ECU assy, perform initialization of linear solenoid valve and calibration (see page 05-958).