

WARNING LIGHT CIRCUIT

CIRCUIT DESCRIPTION

Headlamp beam level control ECU sends the warning signal to the combination meter.

WIRING DIAGRAM

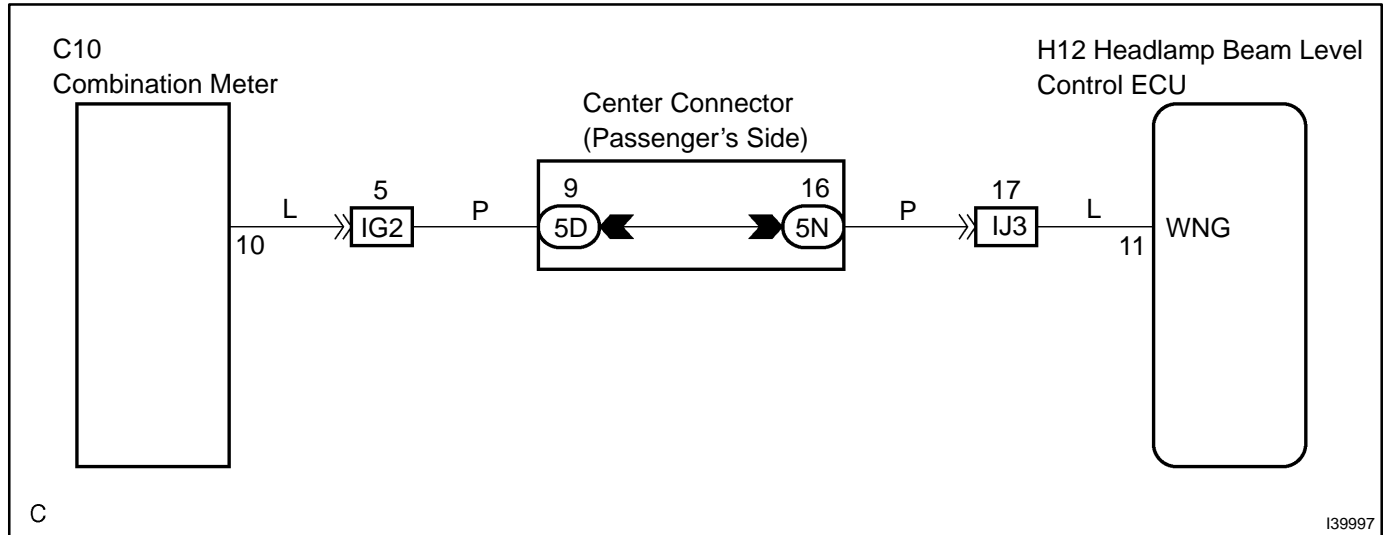

INSPECTION PROCEDURE

HINT:

Check if the combination meter operation is normal before performing the following procedure.

1 INSPECT HEADLAMP LEVELING ECU ASSY

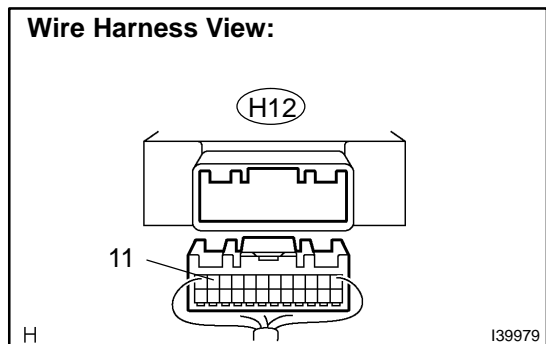

- (a) Disconnect the connector from the headlamp leveling ECU.
- (b) Measure the voltage according to the value(s) in the table below.

Standard:

Tester connection	Condition	Specified condition
H12-11 (WNG) - Body ground	Power switch ON (IG)	10 to 14 V

NG → Go to step 2

OK

PROCEED TO NEXT CIRCUIT INSPECTION SHOWN IN PROBLEM SYMPTOMS TABLE (SEE PAGE 05-1677)

2 CHECK HARNESS AND CONNECTOR(COMBINATION METER ASSY - HEADLAMP LEVELING ECU ASSY)

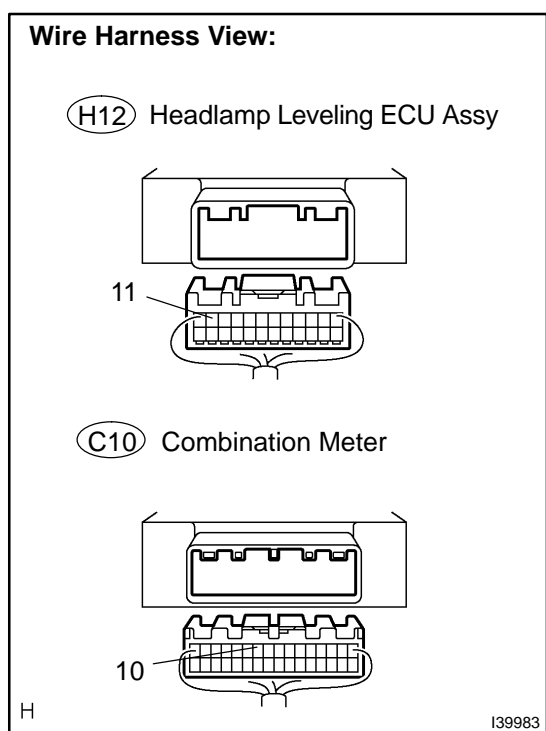

- (a) Disconnect the combination meter connector and headlamp beam level control ECU connector.
- (b) Measure the resistance according to the value(s) in the table below.

Standard:

Tester connection	Condition	Specified condition
H12-11 - C10-10	Always	Below 1 Ω
H12-11 - Body ground	Always	10 kΩ or higher

NG → REPAIR OR REPLACE HARNESS OR CONNECTOR

OK

REPLACE COMBINATION METER ASSY