

<b>DTC</b>	<b>P1120</b>	<b>COOLANT FLOW CONTROL VALVE POSITION SENSOR CIRCUIT</b>
------------	--------------	---

<b>DTC</b>	<b>P1122</b>	<b>COOLANT FLOW CONTROL VALVE POSITION SENSOR CIRCUIT LOW</b>
------------	--------------	---

<b>DTC</b>	<b>P1123</b>	<b>COOLANT FLOW CONTROL VALVE POSITION SENSOR CIRCUIT HIGH</b>
------------	--------------	--

**HINT:**

Although each DTC title says "Coolant Flow Control Valve", these DTCs are related to the water valve.

**CIRCUIT DESCRIPTION**

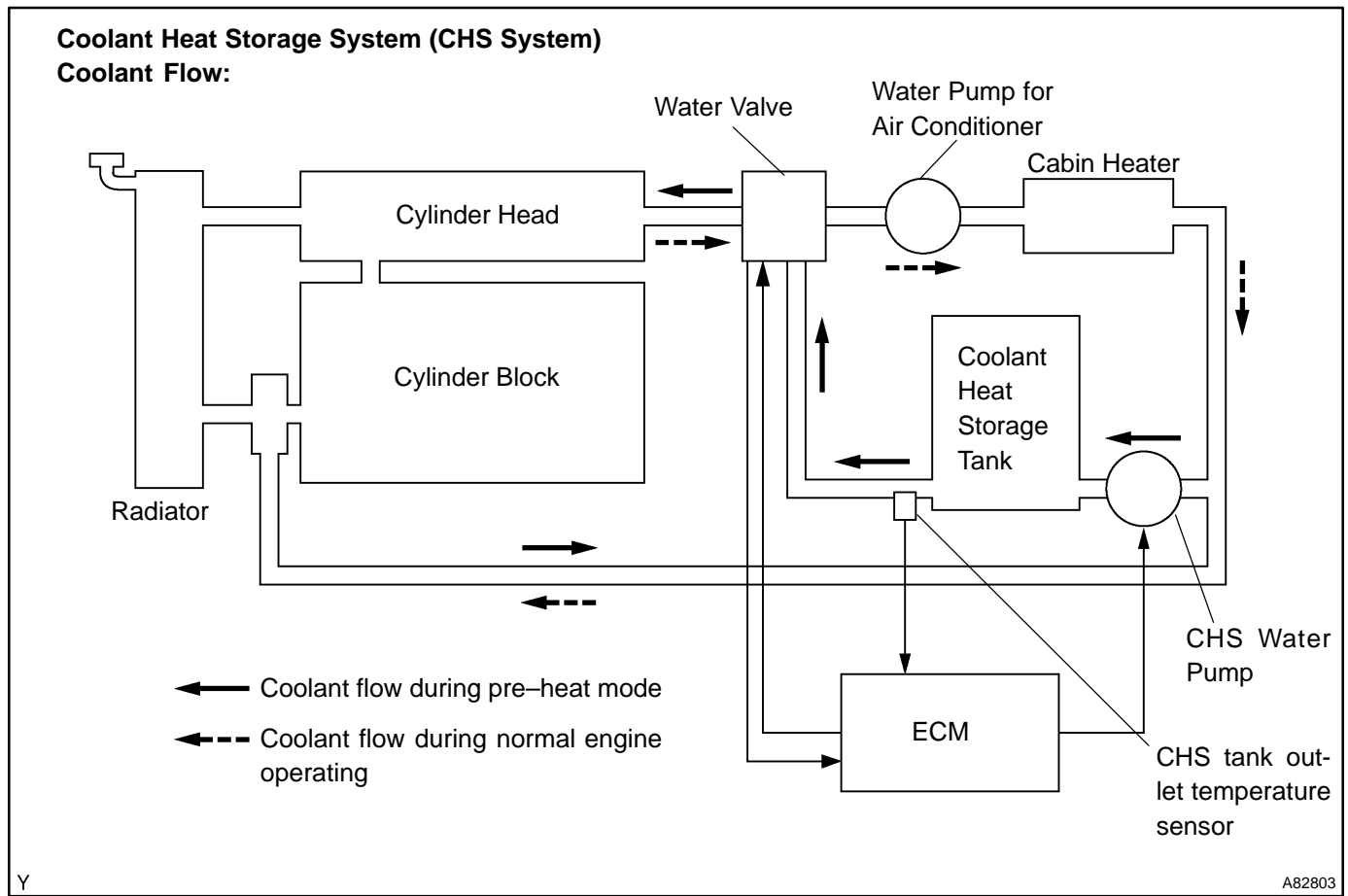

This system uses an electric pump to supply hot coolant stored in the heat storage tank into the cylinder head of the engine, in order to optimize engine starting combustion and reduce the amount of unburned gas that is discharged while the engine is started. Before the engine starts, the ECM operates the electric water pump to direct the hot coolant in the heat storage tank into the engine, in order to heat the cylinder head (this process is called "preheat mode"). The duration of the operation of the electric water pump is variable, depending on the temperature of the cylinder head. During the normal operation of the engine, the water valve opens the passage between the cylinder head and the heater and closes the passage between the cylinder head and the tank. During preheat mode in which the cylinder head is heated, the water valve opens the passage between the tank and the cylinder head, in order to allow the coolant to flow from the tank to the cylinder head. At this time, in order to warm up the intake port quickly before the engine is started, the coolant flows in the reverse direction.

The water valve for the coolant heat storage (CHS) system, which is located at the heater hoses, controls the coolant passages to the engine, heater core, and the CHS tank in accordance with the operating conditions of the system.

The water valve consists of a water valve, valve position sensor, and valve control motor. The potentiometer, which is coupled coaxially to the water valve, converts the valve position into voltage and transmits it to the ECM in the form of a position signal.

DTC No.	Detection Condition	Trouble Area
P1120	WBAD is less than 0.2V or more than 4.8V	<ul style="list-style-type: none"> <li>• Open or short in water valve position sensor circuit</li> <li>• Water valve (Coolant flow control valve)</li> <li>• ECM</li> </ul>
P1122	WBAD stays less than 0.2V for 2 seconds or more	<ul style="list-style-type: none"> <li>• Water valve (Coolant flow control valve)</li> <li>• Short in WBAD circuit</li> <li>• Open in VC circuit</li> <li>• ECM</li> </ul>
P1123	WBAD stays more than 4.8V for 2 seconds or more	<ul style="list-style-type: none"> <li>• Water valve (Coolant flow control valve)</li> <li>• Open in WBAD circuit</li> <li>• Open in E2 circuit</li> <li>• VC and WBAD circuits are short-circuited</li> <li>• ECM</li> </ul>

## MONITOR DESCRIPTION

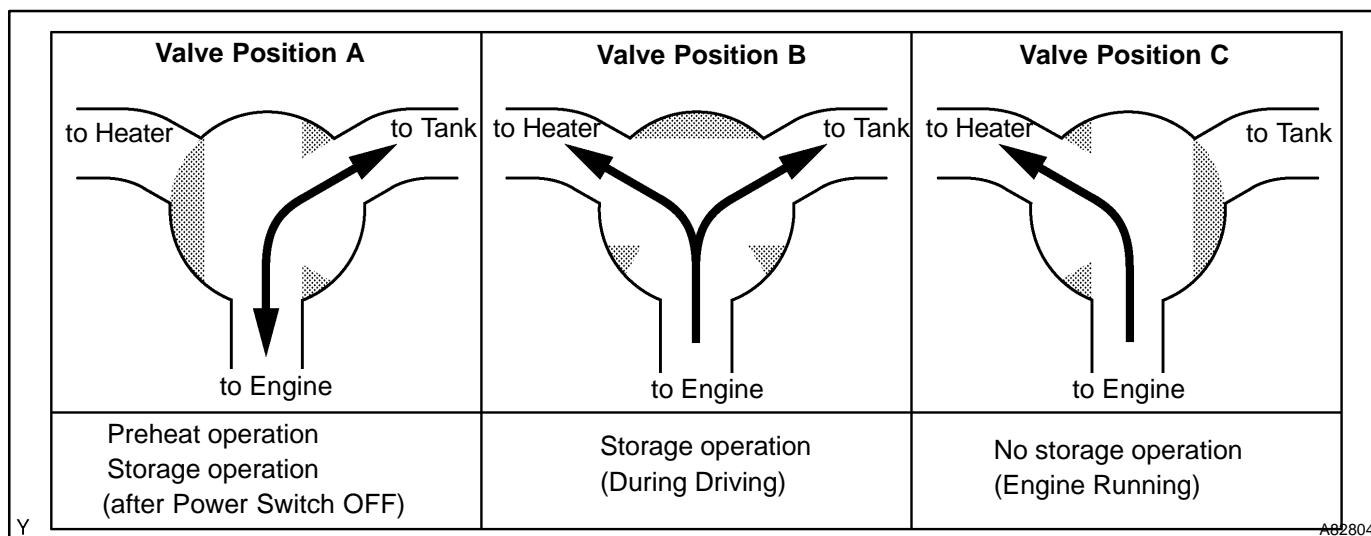

A potentiometer is provided in the coolant heat storage (CHS) system. The ECM uses the valve position signal output by the water valve for effecting control that is appropriate for the operating condition of the engine. The water valve effects control in three steps as indicated below, and the ECM determines the position of the valve according to the voltage of the respective step.

If the signal output by the water valve exceeds the normal range, the ECM determines that a malfunction has occurred in the water valve position sensor circuit and outputs a DTC.

### Water Valve Operation

System Condition	Valve Position	Coolant Flow
Normal engine operation	C	Engine to Cabin heater
Preheat mode	A	Coolant heat storage tank to Engine
Coolant recovering (after engine stop)	A	Engine to Coolant heat storage tank
Coolant recovering (while engine is running)	B	Engine to Cabin heater and Coolant heat storage tank
Soak mode	A	Coolant heat storage tank to Engine

## MONITOR STRATEGY

Related DTCs	<ul style="list-style-type: none"> <li>• P1120: Coolant flow control valve (Water valve) position sensor circuit range check (fluttering)</li> <li>• P1122: Coolant flow control valve (Water valve) position sensor circuit range check (low voltage)</li> <li>• P1123: Coolant flow control valve (Water valve) position sensor circuit range check (high voltage)</li> </ul>
Required sensors / components	Water valve position sensor
Frequency of operation	Continuous
Duration	2 seconds
MIL operation	Immediately
Sequence of operation	None

## TYPICAL ENABLING CONDITIONS

The monitor will run whenever the following DTCs are not present	See page <a href="#">05-20</a>
--	--------------------------------

## TYPICAL MALFUNCTION THRESHOLDS

### P1120:

Water valve position signal	Less than 0.2V or more than 4.8V
-----------------------------	----------------------------------

### P1122:

Water valve position signal	Less than 0.2V
-----------------------------	----------------

### P1123:

Water valve position signal	More than 4.8V
-----------------------------	----------------

## COMPONENT OPERATING RANGE

Water valve position signal	0.4 to 2.2V
-----------------------------	-------------

# WIRING DIAGRAM

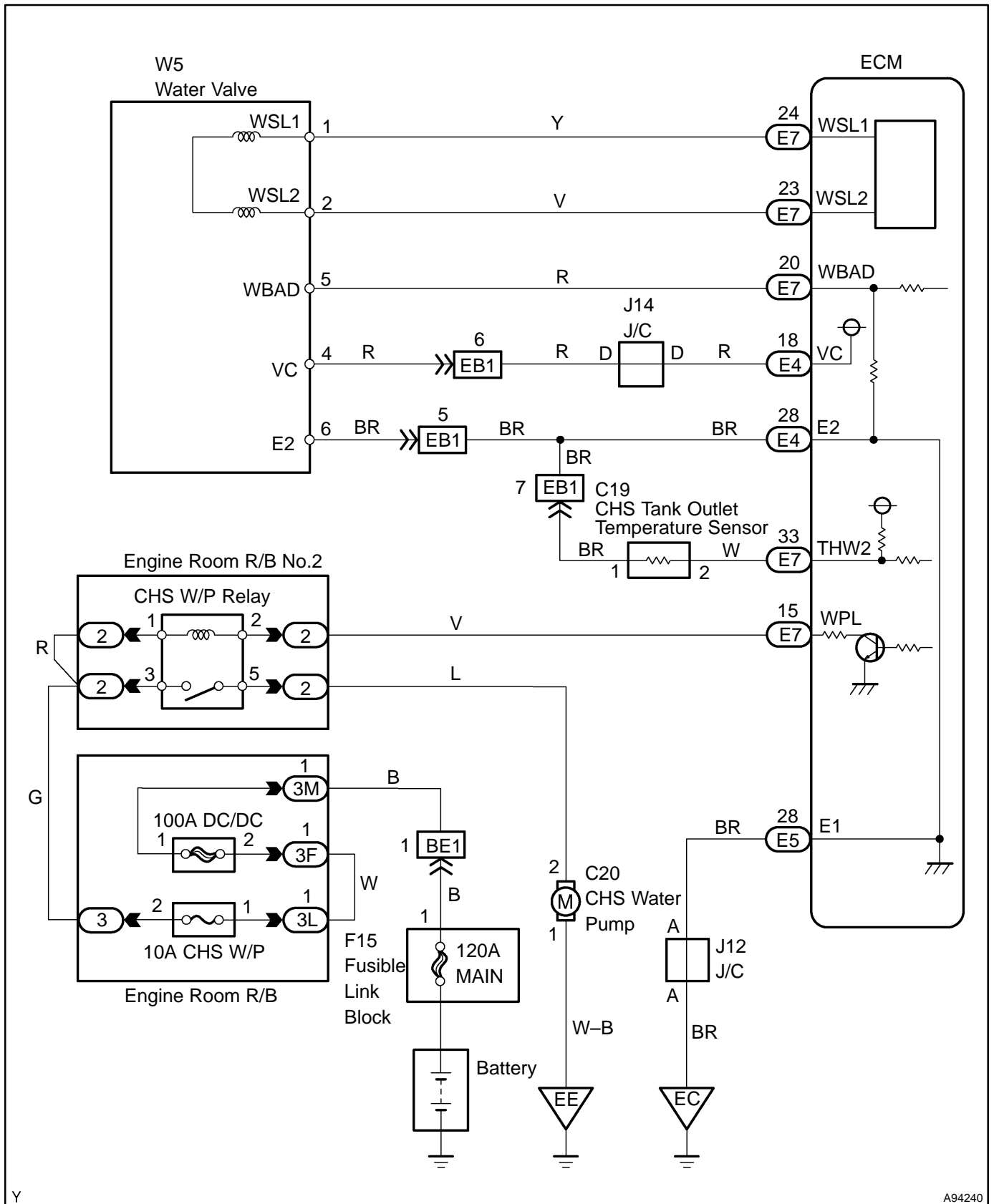

Y

A94240

## INSPECTION PROCEDURE

### CAUTION:

Be careful when replacing any part in the system or changing the coolant because the coolant in the heat storage tank is hot even if the engine is cold.

### HINT:

- To check the coolant heat storage (CHS) system, the ECM may cause the water pump of the CHS system to operate 5 hours after the power switch has been turned OFF.
- Read freeze frame data using the hand-held tester or the OBD II scan tool. Freeze frame data records the engine condition when malfunction is detected. When troubleshooting, it is useful for determining whether the vehicle was running or stopped, the engine was warmed up or not, the air-fuel ratio was lean or rich, etc. at the time of the malfunction.

## 1 INSPECT ECM (WBAD - E2 VOLTAGE)

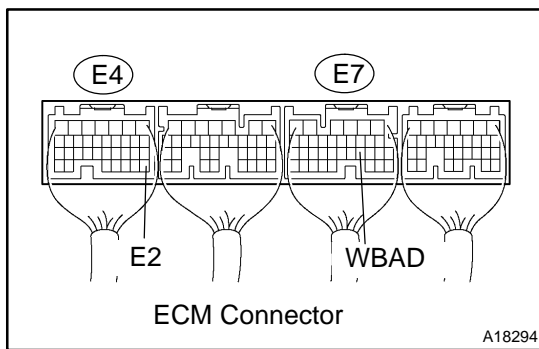

- Turn the power switch ON (IG).
- Measure voltage between the terminals WBAD and E2 of the E4 and E7 ECM connectors.

### Standard:

Throttle Valve	Voltage V
Valve position "A" (Preheat mode)	Approximately 2.5 V
Valve position "B" (Recovering mode)	Approximately 3.5 V
Valve position "C" (Normal Operation)	Approximately 4.5 V

### HINT:

After the HV main system is turned OFF (READY to IG OFF condition), the valve position will be set to position A.

**OK** CHECK FOR INTERMITTENT PROBLEMS (See page 05-17)

**NG**

## 2 INSPECT WATER W/BRACKET VALVE ASSY

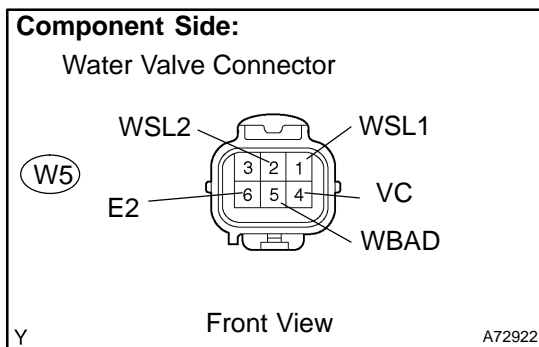

- Disconnect the W5 water valve connector.
- Measure resistance between terminals WSL1 and WSL2 of the water valve connector.
- Measure resistance between terminals WBAD and E2 of the water valve connector.

### RESISTANCE:

Terminals	Condition	Resistance kΩ
1 - 2	Motor resistance	Approximately 0.04
5 - 6	Sensor resistance	0.2 to 5.7

**NG** REPLACE WATER W/BRACKET VALVE ASSY

**OK**

**3 CHECK HARNESS AND CONNECTOR(WATER VALVE - ECM)**

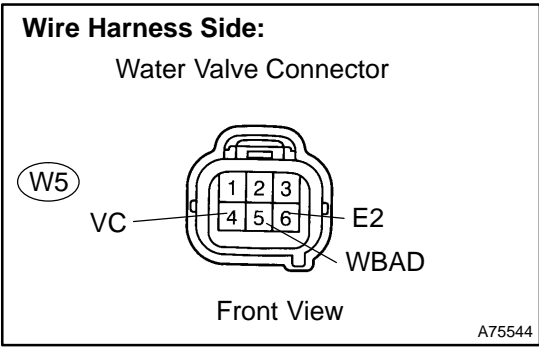

- (a) Disconnect the W5 water valve connector.
- (b) Disconnect the E4 and E7 ECM connectors.
- (c) Check the resistance between the wire harness side connectors.

**Standard (Check for open):**

Tester Connection	Specified Condition
Water valve (W5-5) - WBAD (E7-20)	Below 1 Ω
Water valve (W5-4) - VC (E4-18)	Below 1 Ω
Water valve (W5-6) - E2 (E4-28)	Below 1 Ω

**Standard (Check for short):**

Tester Connection	Specified Condition
Water valve (W5-5) or WBAD (E7-20) - Body ground	10 kΩ or higher

- (d) Reconnect the water valve connector.
- (e) Reconnect the ECM connectors.

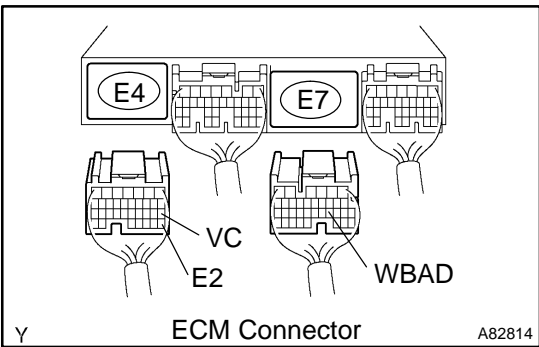

**NG** → **REPAIR OR REPLACE HARNESS OR CONNECTOR**

**OK**

**REPLACE ECM (See page 10-24)**