

DTC	B1498	COMMUNICATION MALFUNCTION (A/C INVERTER LOCAL)
------------	--------------	---

CIRCUIT DESCRIPTION

The hybrid control ECU and A/C inverter assy transmit information to one another via communication line. Compressor control is stopped and the DTC is output if communication information is cut off or abnormal information occurs.

The output DTC is memorized as previous trouble.

DTC No.	Detection item	Trouble Area
B1498	Communication line error or open between the hybrid control ECU and the A/C inverter (w/converter inverter assy)	<ul style="list-style-type: none"> • Harness or connector between hybrid control ECU and A/C inverter (w/converter inverter assy) • Hybrid control ECU • A/C inverter (w/converter inverter assy)

WIRING DIAGRAM

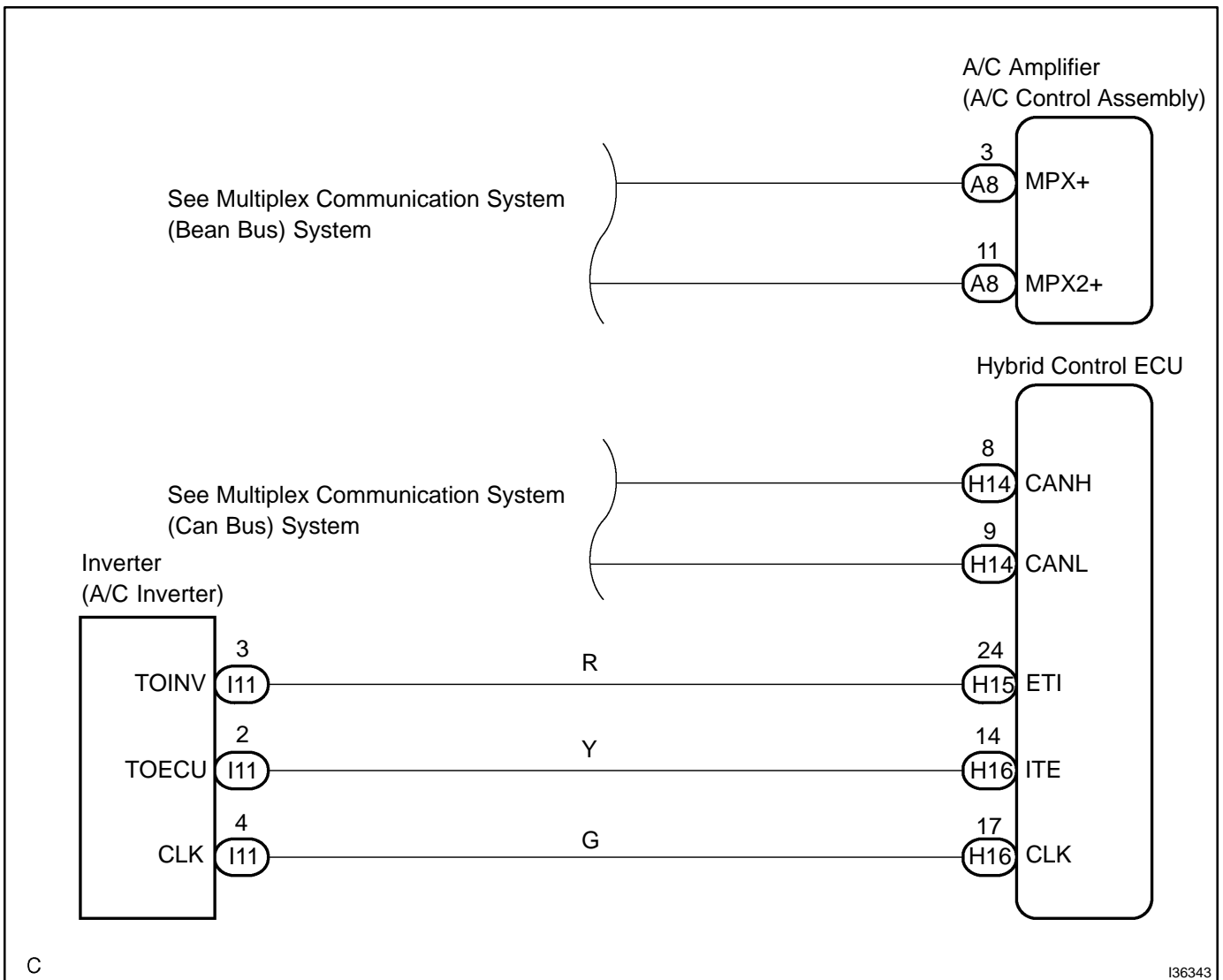

C

I36343

INSPECTION PROCEDURE

1 CHECK HARNESS AND CONNECTOR (HYBRID VEHICLE CONTROL ECU AND W/ CONVERTER INVERTER ASSY)

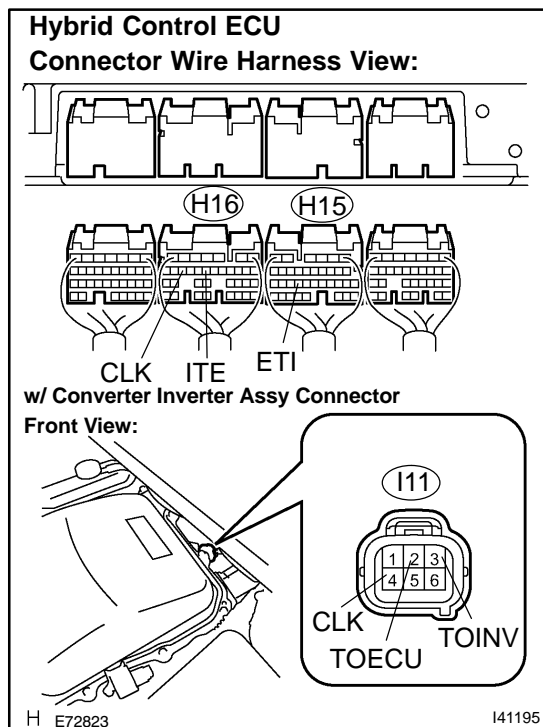

- (a) Disconnect the hybrid control ECU connector.
- (b) Disconnect the A/C inverter connector.
- (c) Measure the resistance according to the value(s) in the table below.

Standard:

Tester connection	Condition	Specified condition
H15-24 (ETI) - I11-3 (TOINV)	Always	Below 1 Ω
H16-14 (ITE) - I11-2 (TOECU)	Always	Below 1 Ω
H16-17 (CLK) - I11-4 (CLK)	Always	Below 1 Ω
H15-24 (ETI) - Body ground	Always	10 kΩ or higher
H16-14 (ITE) - Body ground	Always	10 kΩ or higher
H16-17 (CLK) - Body ground	Always	10 kΩ or higher

NG REPAIR OR REPLACE HARNESS OR CONNECTOR

OK

2 CHECK DIAGNOSTIC TROUBLE CODE

- (a) Connect the hybrid control ECU connector.
- (b) Connect the A/C inverter connector.
- (c) Check if DTCs for the hybrid control system are output using intelligent tester II.

OK:

DTCs are not output in the hybrid control system.

NG GO TO HYBRID CONTROL SYSTEM (SEE PAGE 05-440)

OK

REPLACE A/C INVERTER

NOTICE:

The A/C inverter is integrated with the inverter assy. It is necessary to replace the PCU box assy if the A/C inverter (inverter assy) needs to be replaced because the A/C inverter (inverter assy) cannot be replaced alone.