

DTC	B1431	AIR MIX DAMPER POSITION SENSOR CIRCUIT (PASSENGER SIDE)
------------	--------------	--

CIRCUIT DESCRIPTION

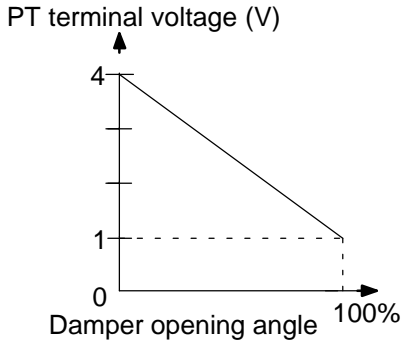

This sensor detects the position of the air mix control servomotor (air mix damper) and sends the appropriate signals to the A/C amplifier. The position sensor is built in the air mix control servomotor. The position sensor resistance changes as the air mix control servomotor arm moves.

It outputs voltage (5V) that is input to terminal 1 (VZ) and terminal 3 (PT) via the variable resistor, and then to the A/C amplifier. The A/C amplifier reads the arm position with the input voltage from the position sensor.

DTC No.	Detection Item	Trouble Area
B1431	Open or short in power source circuit in air mix damper position sensor circuit.	<ul style="list-style-type: none"> • Air mix control servomotor (air mix damper position sensor) • Harness or connector between Air mix control servomotor and A/C amplifier • A/C amplifier

WIRING DIAGRAM

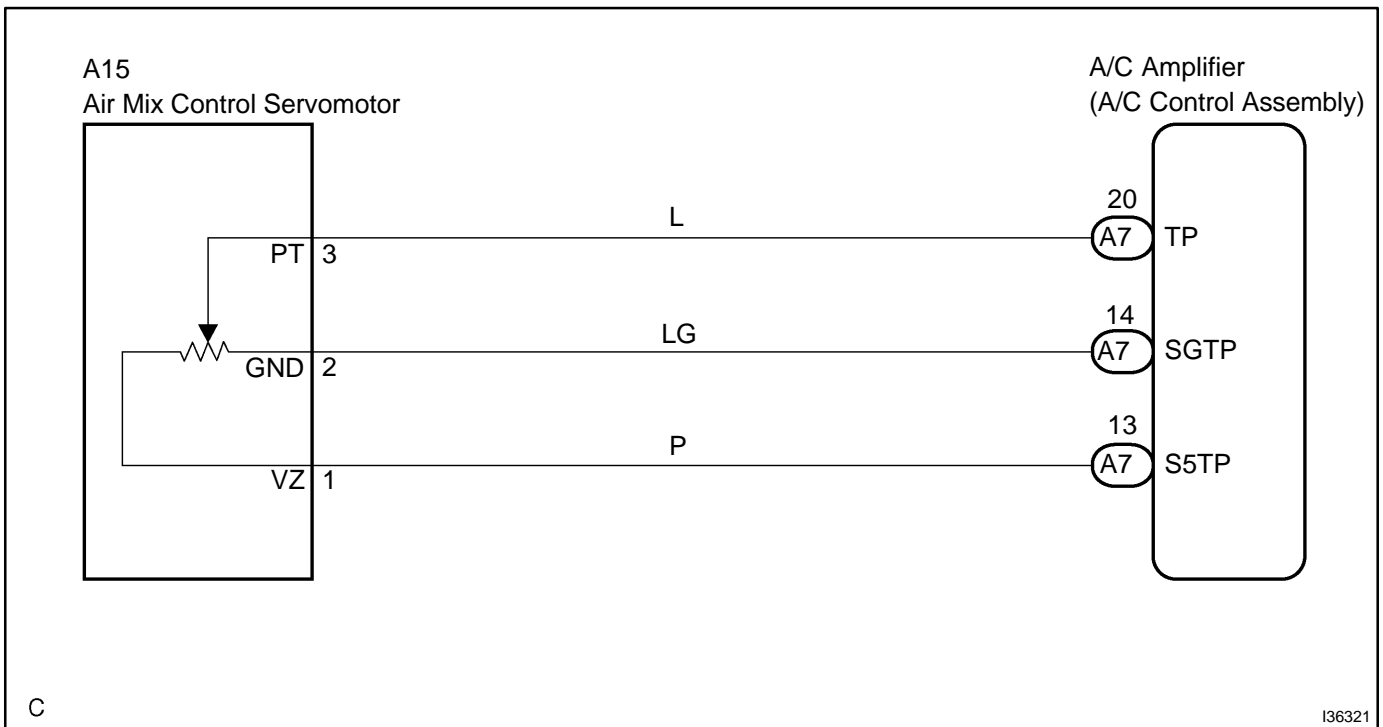

INSPECTION PROCEDURE

1 READ VALUE ON HAND-HELD TESTER

- (a) Connect the hand-held tester to DLC3.
- (b) Turn the power switch ON and push the hand-held tester main switch ON.
- (c) Select the item below in the DATA LIST, and read the display on the hand-held tester.

DATA LIST / AIR CONDITIONER:

Item	Measurement Item/Display (Range)	Normal Condition	Diagnostic Note
A/M DAMP POS-D	Air mix damper position (Driver side) / min.: -14% max.: 113.5%	Damper is at "MAX. COOL": -10.0% Damper is at "MAX. HOT": 100.0% or 71.0%	-
A/M DAMP TARG-D	Air mix damper target position (Driver side) / min.: -14% max.: 113.5%	Damper is at "MAX. COOL": -10.0% Damper is at "MAX. HOT": 100.0% or 71.0%	-

OK:

The displayed is as specified in the normal condition.

Result:

NG	A
OK (Checking from the PROBLEM SYMPTOM TABLE)	B
OK (Checking from the DTC)	C

B → PROCEED TO NEXT CIRCUIT INSPECTION SHOWN IN PROBLEM SYMPTOMS TABLE (SEE PAGE 05-1268)

C → REPLACE AIR CONDITIONING AMPLIFIER (SEE PAGE 55-47)

A

2 INSPECT AIR CONDITIONING AMPLIFIER(TP - SGTP)

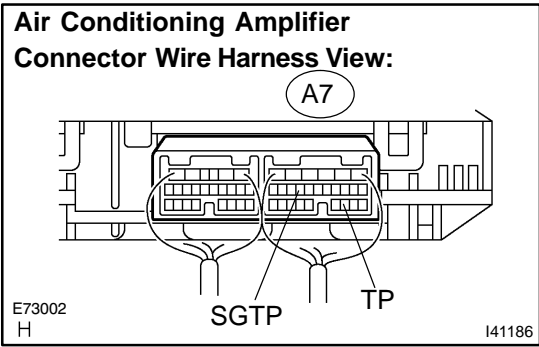

- (a) Remove the A/C amplifier with connectors still connected.
- (b) Change the set temperature to activate the air mix servomotor.
- (c) Measure the voltage according to the value(s) in the table below.

Standard:

Tester connection	Condition	Specified condition
A7-20 (TP) - A7-14 (SGTP)	Power switch ON (ON) MAX. Hot Position	0.97 to 1.03 V
A7-20 (TP) - A7-14 (SGTP)	Power switch ON (ON) MAX. Cool Position	3.97 to 4.03 V

HINT:

As the set temperature increases, the voltage decreases gradually without interruption.

Result:

NG	A
OK (Checking from the PROBLEM SYMPTOMS TABLE)	B
OK (Checking from the DTC)	C

B → **PROCEED TO NEXT CIRCUIT INSPECTION SHOWN IN PROBLEM SYMPTOMS TABLE (SEE PAGE 05-1268)**

C → **REPLACE AIR CONDITIONING AMPLIFIER (SEE PAGE 55-47)**

A

3 INSPECT AIR MIX CONTROL SERVOMOTOR

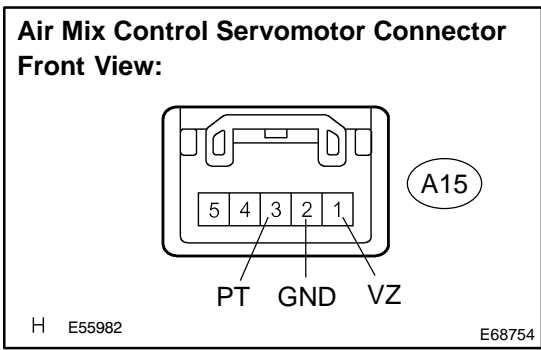

- (a) Remove the air mix control servomotor.
- (b) Disconnect the connector from air mix control servomotor.
- (c) Measure the resistance according to the value(s) in the table below.

Standard:

Tester connection	Condition	Specified condition
A15-1 (VZ) – A15-2 (GND)	Always	4.2 to 7.8 kΩ

- (d) Measure the resistance according to the value(s) in the table below.

HINT:

See page 05-1320 for the operation procedure for air mix control servomotor.

Standard:

Tester connection	Condition	Specified condition
A15-3 (PT) – A15-2 (GND)	Max. Cool Position	3.6 to 6.7 kΩ
A15-3 (PT) – A15-2 (GND)	Max. Hot Position	0.8 to 1.6 kΩ

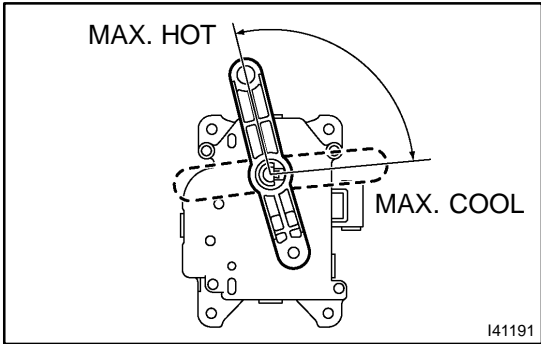

- (e) As the air mix control servomotor moves from cool side to hot side, the resistance decreases gradually without interruption.

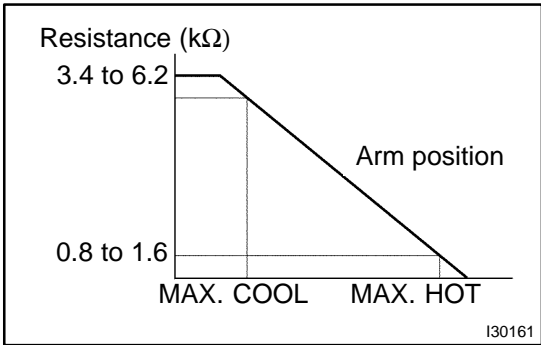

NG → **REPLACE AIR MIX CONTROL SERVOMOTOR**

OK

4 CHECK HARNESS AND CONNECTOR(AIR MIX CONTROL SERVOMOTOR - AIR CONDITIONING AMPLIFIER) (SEE PAGE 01-47)

Air Mix Control Servomotor Connector Front View:

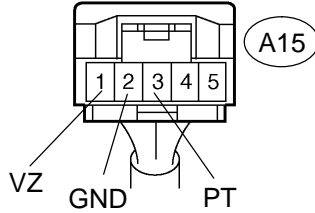

Air Conditioning Amplifier Connector Wire Harness View:

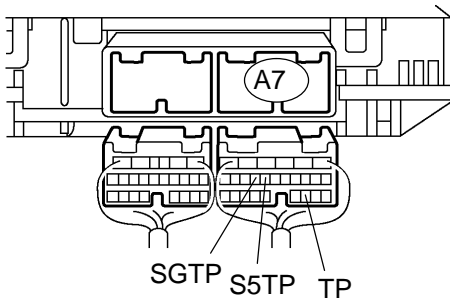

C

I36370

- (a) Disconnect the connector air mix control servomotor.
- (b) Measure the resistance according to the value(s) in the table below.

Standard:

Tester connection	Condition	Specified condition
A7-20 (TP) - A15-3 (PT)	Always	Below 1 Ω
A7-14 (SGTP) - A15-2 (GND)	Always	Below 1 Ω
A7-13 (S5TP) - A15-1 (VZ)	Always	Below 1 Ω
A7-20 (TP) - Body ground	Always	10 kΩ or higher
A7-14 (SGTP) - Body ground	Always	10 kΩ or higher
A7-13 (S5TP) - Body ground	Always	10 kΩ or higher

NG REPAIR OR REPLACE HARNESS OR CONNECTOR

OK

REPLACE AIR CONDITIONING AMPLIFIER (SEE PAGE 55-47)