

DTC	B1820/55	SHORT IN SIDE SQUIB (D SEAT SIDE) CIRCUIT
------------	-----------------	--

CIRCUIT DESCRIPTION

The side squib (D seat side) circuit consists of the airbag ECU Assy and the front seat w/ adjuster frame Assy LH (side squib (D seat side)).

This circuit instructs the SRS to deploy when deployment conditions are met.

DTC B1820 is recorded when a short circuit is detected in the side squib (D seat side) circuit.

DTC No.	DTC Detecting Condition	Trouble Area
B1820	<ul style="list-style-type: none"> • When the airbag ECU Assy receives a line short signal 5 times in the side squib (D seat side) circuit during primary check. • Side squib (D seat side) malfunction • Airbag ECU Assy malfunction 	<ul style="list-style-type: none"> • Floor wire • Seat airbag No.1 wire • Front seat w/ adjuster frame Assy LH (Side squib (D seat side)) • Airbag ECU Assy

WIRING DIAGRAM

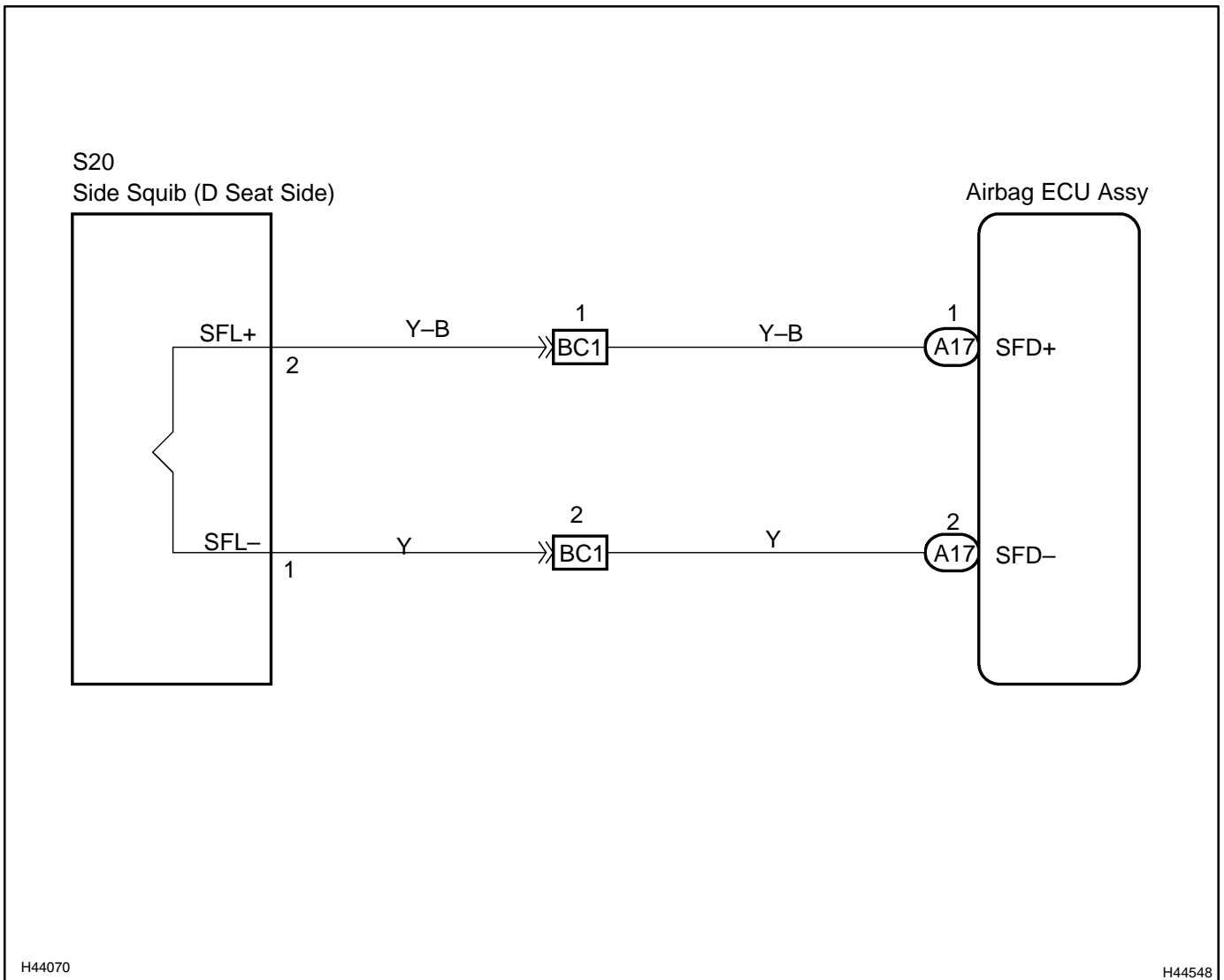

H44070

H44548

INSPECTION PROCEDURE

CAUTION:

Be sure to perform the following procedures before troubleshooting to avoid unexpected airbag deployment.

- (a) Turn the power switch off.
- (b) Disconnect the negative (-) terminal cable from the battery, and wait for at least 90 seconds.
- (c) Disconnect the connectors from the airbag ECU assy.
- (d) Disconnect the connectors from the horn button assy.
- (e) Disconnect the connectors from the front passenger airbag assy.
- (f) Disconnect the connector from the front seat airbag assy LH.
- (g) Disconnect the connector from the front seat airbag assy RH.
- (h) Disconnect the connector from the curtain shield airbag assy LH.
- (i) Disconnect the connector from the curtain shield airbag assy RH.
- (j) Disconnect the connector from the front seat outer belt assy LH.
- (k) Disconnect the connector from the front seat outer belt assy RH.

1 CHECK SIDE SQUIB (D SEAT SIDE) CIRCUIT

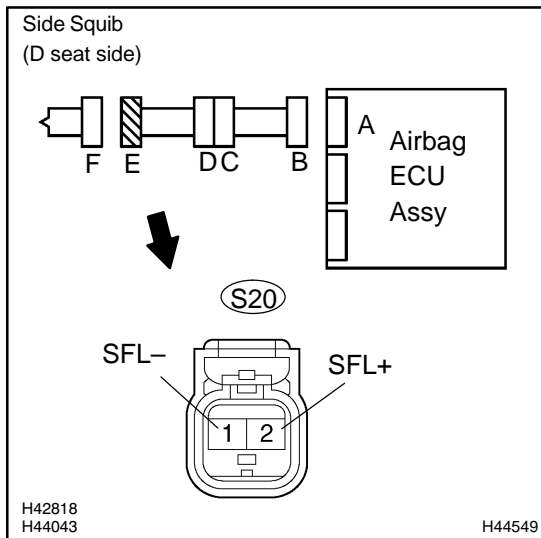

- (a) Release the activation prevention mechanism built into connector "B" (see page 05-1397).
- (b) Measure the resistance according to the value(s) in the table below.

Standard:

Tester connection	Condition	Specified condition
S20-2 (SFL+) – S20-1 (SFL-)	Always	1 MΩ or Higher

OK

NG Go to step 4

2 CHECK AIR BAG ECU ASSY

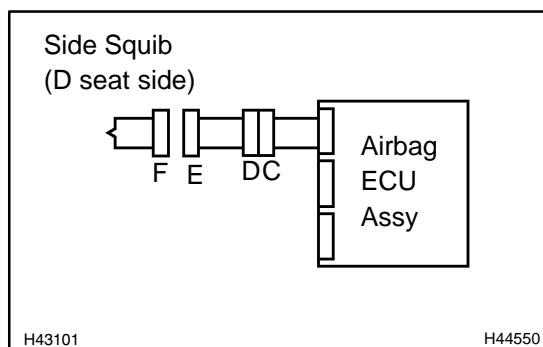

- (a) Connect the connectors to the airbag ECU assy.
- (b) Connect the negative (–) terminal cable to the battery, and wait for at least 2 seconds.
- (c) Turn the power switch on (IG), and wait for at least 60 seconds.
- (d) Clear the DTCs stored in memory (see page 05-1402).
- (e) Turn the power switch off.
- (f) Turn the power switch on (IG), and wait for at least 60 seconds.
- (g) Check the DTCs (see page 05-1402).

OK:

DTC B1820 is not output.

HINT:

Codes other than code B1820 may be output at this time, but they are not related to this check.

NG

**REPLACE AIR BAG ECU ASSY
(SEE PAGE 60-54)**

OK

3	CHECK FRONT SEAT W/ADJUSTER FRAME ASSY LH(SIDE SQUIB (D SEAT SIDE))
----------	--

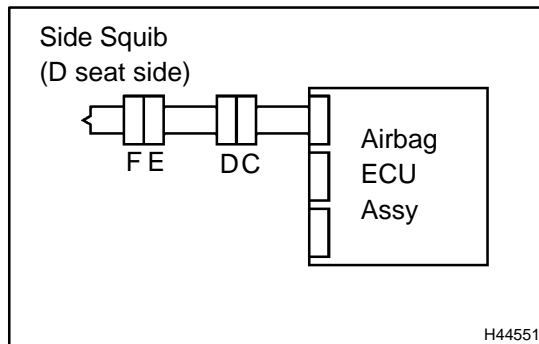

- (a) Turn the power switch off.
- (b) Disconnect the negative (-) terminal cable from the battery, and wait for at least 90 seconds.
- (c) Connect the connector to the front seat w/ adjuster frame assy LH (side squib (D seat side)).
- (d) Connect the negative (-) terminal cable to the battery, and wait for at least 2 seconds.
- (e) Turn the power switch on (IG), and wait for at least 60 seconds.
- (f) Clear the DTCs stored in memory (see page 05-1402).
- (g) Turn the power switch off.
- (h) Turn the power switch on (IG), and wait for at least 60 seconds.
- (i) Check the DTCs (see page 05-1402).

OK:

DTC B1820 is not output.

HINT:

Codes other than code B1820 may be output at this time, but they are not related to this check.

NG

REPLACE FRONT SEAT W/ADJUSTER FRAME ASSY LH (SEE PAGE 72-2)

OK

USE SIMULATION METHOD TO CHECK (SEE PAGE 05-1397)

HINT:

- Perform the simulation method by selecting the check mode with the hand-held tester (see page 05-1405).
- After selecting the check mode, perform the simulation method by wiggling each connector of the air-bag system or driving the vehicle on a city or rough road (see page 05-1405).

4 CHECK FLOOR WIRE

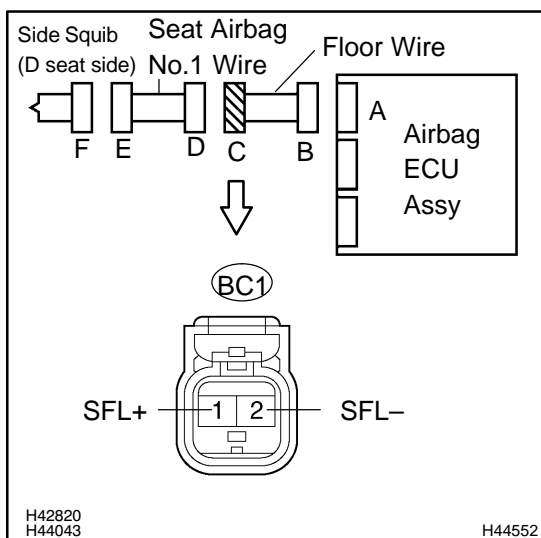

- (a) Disconnect the floor wire connector from the seat airbag No.1 wire.

HINT:

The activation prevention mechanism of connector "B" has already been released.

- (b) Measure the resistance according to the value(s) in the table below.

Standard:

Tester connection	Condition	Specified condition
BC1-1 (SFL+) - BC1-2 (SFL-)	Always	1 MΩ or Higher

NG

REPAIR OR REPLACE FLOOR WIRE

OK

5 CHECK SEAT AIRBAG NO.1 WIRE

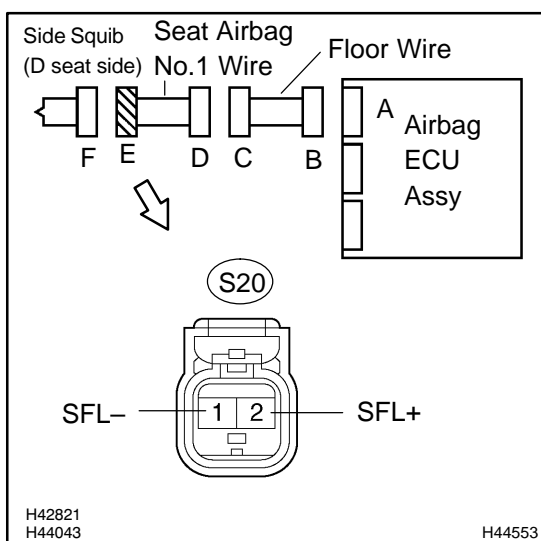

- (a) Release the activation prevention mechanism built into connector "D" (see page 05-1397).

- (b) Measure the resistance according to the value(s) in the table below.

Standard:

Tester connection	Condition	Specified condition
S20-2 (SFL+) - S20-1 (SFL-)	Always	1 MΩ or Higher

NG

REPAIR OR REPLACE SEAT AIRBAG NO.1 WIRE

OK

USE SIMULATION METHOD TO CHECK (SEE PAGE 05-1397)

HINT:

- Perform the simulation method by selecting the check mode with the hand-held tester (see page 05-1405).
- After selecting the check mode, perform the simulation method by wiggling each connector of the airbag system or driving the vehicle on a city or rough road (see page 05-1405).