

DTC	B1655/37	SEAT BELT BUCKLE SWITCH (D SEAT SIDE) MALFUNCTION
------------	-----------------	--

CIRCUIT DESCRIPTION

The seat belt buckle switch (D seat side) circuit consists of the airbag ECU Assy and the front seat inner belt Assy LH (buckle switch (D seat side)).

DTC B1655 is recorded when a malfunction is detected in the seat belt buckle switch (D seat side) circuit.

DTC No.	DTC Detecting Condition	Trouble Area
B1655	<ul style="list-style-type: none"> • When the airbag ECU Assy receives a line short signal, an open signal, short to ground signal or B+ short signal in the seat belt buckle switch (D seat side) circuit for 2 seconds. • Front seat inner belt Assy LH malfunction • Airbag ECU Assy malfunction 	<ul style="list-style-type: none"> • Floor wire • Front seat inner belt Assy LH (Buckle switch (D seat side)) • Airbag ECU Assy

WIRING DIAGRAM

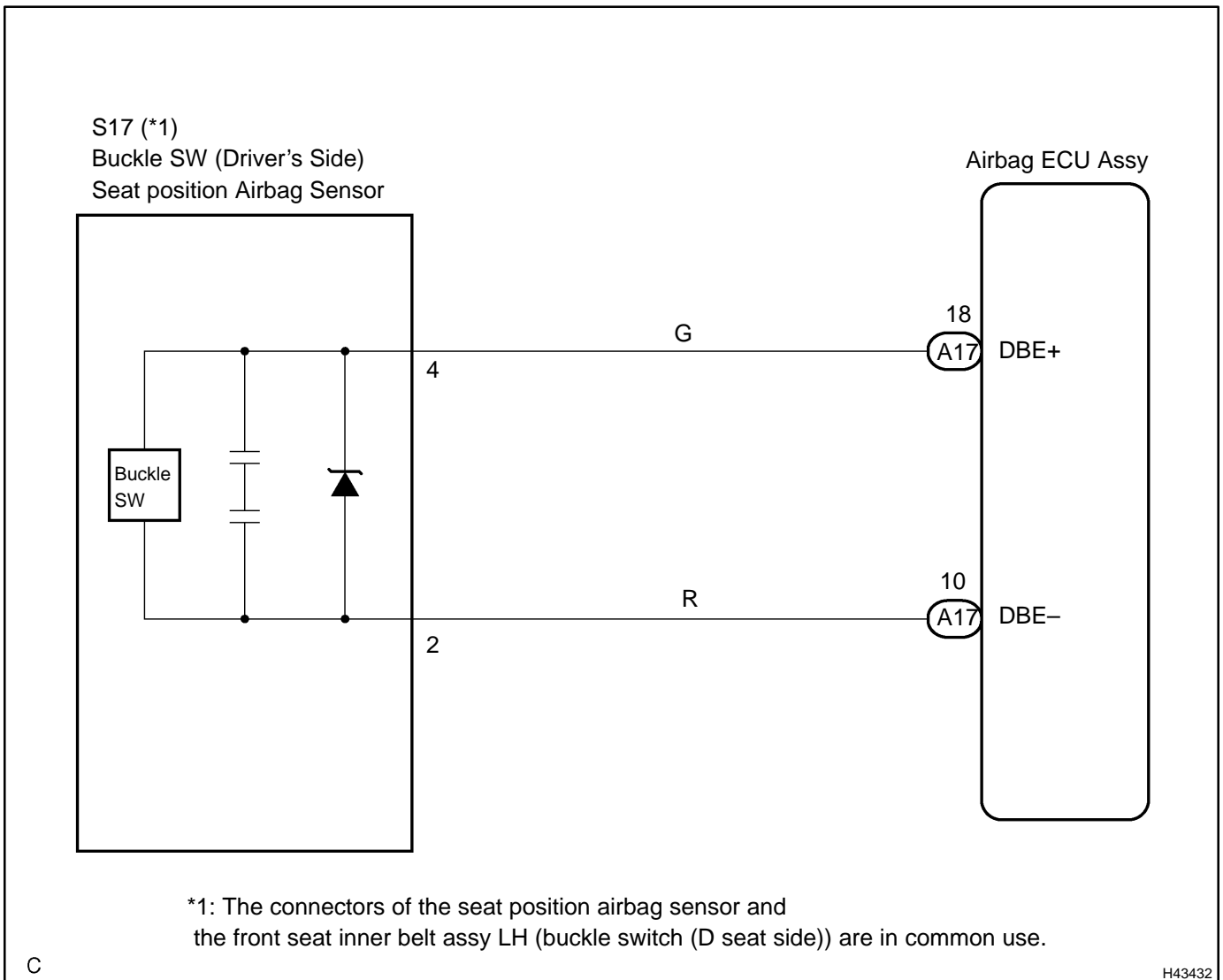

INSPECTION PROCEDURE

CAUTION:

Be sure to perform the following procedures before troubleshooting to avoid unexpected airbag deployment.

- (a) Turn the power switch off.
- (b) Disconnect the negative (–) terminal cable from the battery, and wait for at least 90 seconds.
- (c) Disconnect the connectors from the airbag ECU Assy.
- (d) Disconnect the connectors from the horn button Assy.
- (e) Disconnect the connectors from the front passenger airbag Assy.
- (f) Disconnect the connector from the front seat airbag Assy LH.
- (g) Disconnect the connector from the front seat airbag Assy RH.
- (h) Disconnect the connector from the curtain shield airbag Assy LH.
- (i) Disconnect the connector from the curtain shield airbag Assy RH.
- (j) Disconnect the connector from the front seat outer belt Assy LH.
- (k) Disconnect the connector from the front seat outer belt Assy RH.

1 CHECK DTC

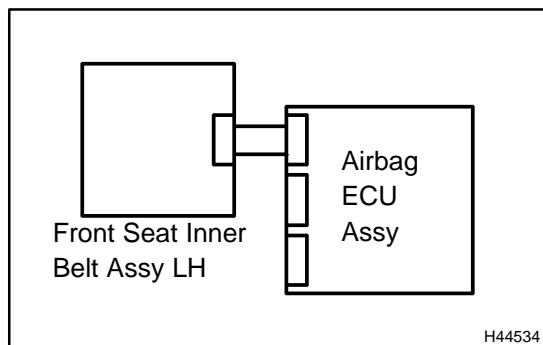

- (a) Connect the connectors to the airbag ECU Assy.
- (b) Connect the negative (–) terminal cable to the battery, and wait for at least 2 seconds.
- (c) Turn the power switch on (IG), and wait for at least 60 seconds.
- (d) Clear the DTCs stored in memory (see page 05-1402).
- (e) Turn the power switch off.
- (f) Turn the power switch on (IG) and wait for at least 60 seconds.
- (g) Check the DTCs (see page 05-1402).

OK:

DTC B1655 is not output.

HINT:

Codes other than code B1655 may be output at this time, but they are not related to this check.

NG

Go to step 2

OK

USE SIMULATION METHOD TO CHECK (SEE PAGE 05-1397)

2 CHECK CONNECTION OF CONNECTORS

- (a) Turn the power switch off.
- (b) Disconnect the negative (-) terminal cable from the battery, and wait for at least 90 seconds.
- (c) Check that the connectors are properly connected to the airbag ECU Assy and the front seat inner belt Assy LH.

OK:

The connectors are connected.

NG → **CONNECT CONNECTORS, THEN GO TO STEP 1**

OK

3 CHECK FLOOR WIRE(OPEN)

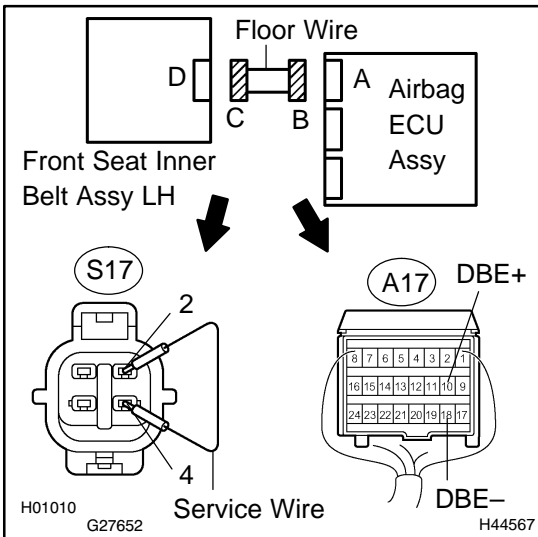

- (a) Disconnect the connectors from the airbag ECU Assy and the front seat inner belt Assy LH.
- (b) Using a service wire, connect S17-2 and S17-4 of connector "C".

NOTICE:

Do not forcibly insert a service wire into the terminals of the connector when connecting.

- (c) Measure the resistance according to the value(s) in the table below.

Standard:

Tester connection	Condition	Specified condition
A17-10 (DBE+) - A17-18 (DBE-)	Always	Below 1 Ω

NG → **REPAIR OR REPLACE FLOOR WIRE**

OK

4 CHECK FLOOR WIRE(SHORT)

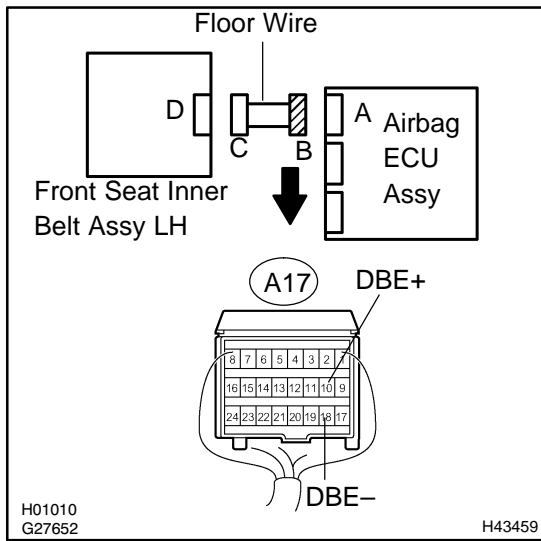

- (a) Disconnect the service wire from connector "C".
- (b) Measure the resistance according to the value(s) in the table below.

Standard:

Tester connection	Condition	Specified condition
A17-1 (DBE+) - A17-18 (DBE-)	Always	1 MΩ or Higher

NG REPAIR OR REPLACE FLOOR WIRE

OK

5 CHECK FLOOR WIRE(TO B+)

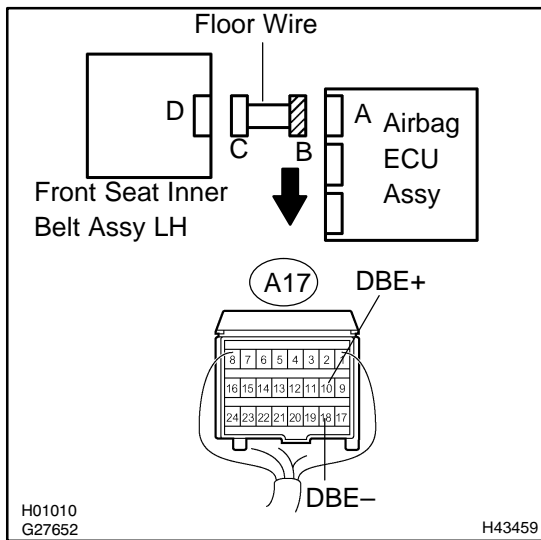

- (a) Connect the negative (-) terminal cable to the battery, and wait for at least 2 seconds.
- (b) Turn the power switch on (IG).
- (c) Measure the voltage according to the value(s) in the table below.

Standard:

Tester connection	Condition	Specified condition
A17-10 (DBE+) - Body ground	Power switch is on (IG)	Below 1 V
A17-18 (DBE-) - Body ground	Power switch is on (IG)	Below 1 V

NG REPAIR OR REPLACE FLOOR WIRE

OK

6 CHECK FLOOR WIRE(TO GROUND)

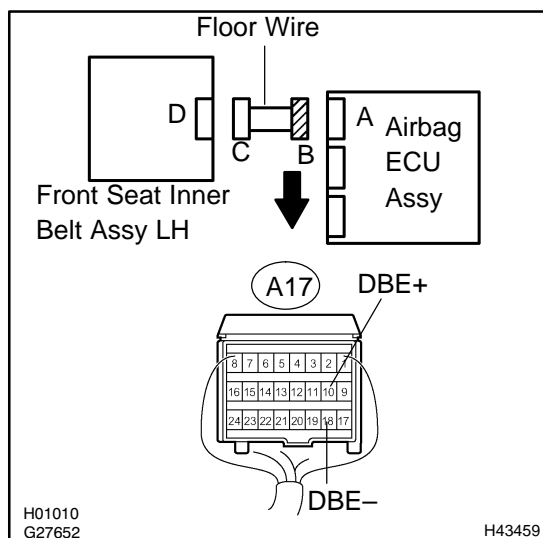

- Turn the power switch off.
- Disconnect the negative (-) terminal cable from the battery, and wait for at least 90 seconds.
- Measure the resistance according to the value(s) in the table below.

Standard:

Tester connection	Condition	Specified condition
A17-10 (DBE+) - Body ground	Always	1 M Ω or Higher
A17-18 (DBE+) - Body ground	Always	1 M Ω or Higher

NG REPAIR OR REPLACE FLOOR WIRE

OK

7 CHECK FRONT SEAT INNER BELT ASSY LH

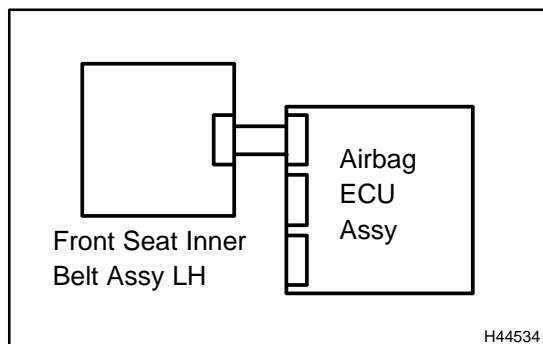

- Connect the connectors to the airbag ECU assy.
- Connect the negative (-) terminal cable to the battery, and wait for at least 2 seconds.
- Turn the power switch on (IG), and wait for at least 60 seconds.
- Clear the DTCs stored in memory (see page 05-1402).
- Turn the power switch off.
- Turn the power switch on (IG), and wait for at least 60 seconds.
- Check the DTCs (see page 05-1402).

OK:

DTC B1655 is not output.

HINT:

Codes other than code B1655 may be output at this time, but they are not related to this check.

NG Go to step 8

OK

USE SIMULATION METHOD TO CHECK (SEE PAGE 05-1397)

8	REPLACE FRONT SEAT INNER BELT ASSY LH
----------	--

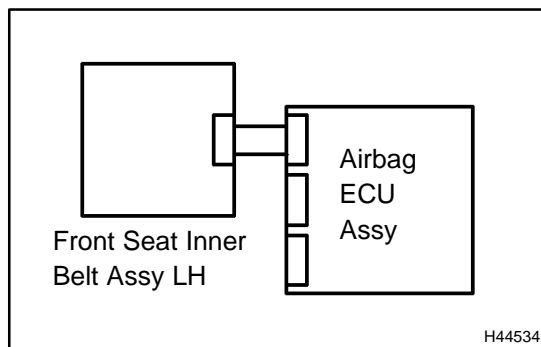

- (a) Turn the power switch off.
- (b) Disconnect the negative (-) terminal cable from the battery, and wait for at least 90 seconds.
- (c) Replace the front seat inner belt assy LH (see page [72-2](#)).

HINT:

Perform the inspection using parts from a normal vehicle when possible.

- (d) Connect the connectors to the airbag ECU assy.
- (e) Connect the negative (-) terminal cable to the battery, and wait for at least 2 seconds.
- (f) Turn the power switch on (IG), and wait for at least 60 seconds.
- (g) Clear the DTCs stored in memory (see page [05-1402](#)).
- (h) Turn the power switch off.
- (i) Turn the power switch on (IG), and wait for at least 60 seconds.
- (j) Check the DTCs (see page [05-1402](#)).

OK:

DTC B1655 is not output.

HINT:

Codes other than code B1655 may be output at this time, but they are not related to this check.

NG	REPLACE AIR BAG ECU ASSY (SEE PAGE 60-54)
-----------	--

OK

END
