

■ FUEL SYSTEM

1. General

- A fuel returnless system is used to reduce evaporative emissions.
- A compact 12-hole type injector is used to improve the atomization of fuel.
- The vapor reducing fuel tank system, which reduces the amount of fuel vapor generated when the vehicle is parked, during refueling, or while driving, has been carried over from the '03 Prius. This system provides a vapor reducing fuel tank that expands or contracts in accordance with the volume of the fuel in the fuel storage area in the fuel tank. By thus reducing the space in which fuel can evaporate, the generation of fuel vapor is minimized.
- The ORVR (On-Board Refueling Vapor Recovery) system is used. On the '04 Prius, the fresh air line inlet of the ORVR system has been relocated from the air cleaner to the fuel inlet. However, its basic operation is the same as the '03 Prius.
- The maximum flow rate of the purge valve has been changed from 40 L/min. to 60 L/min. As a result, the evaporative emissions have been reduced.
- The quick turn & ratchet construction type fuel tank cap has been newly adopted to improve usability.
- A main fuel tube and a purge tube made of aluminum have been adopted for weight reduction.

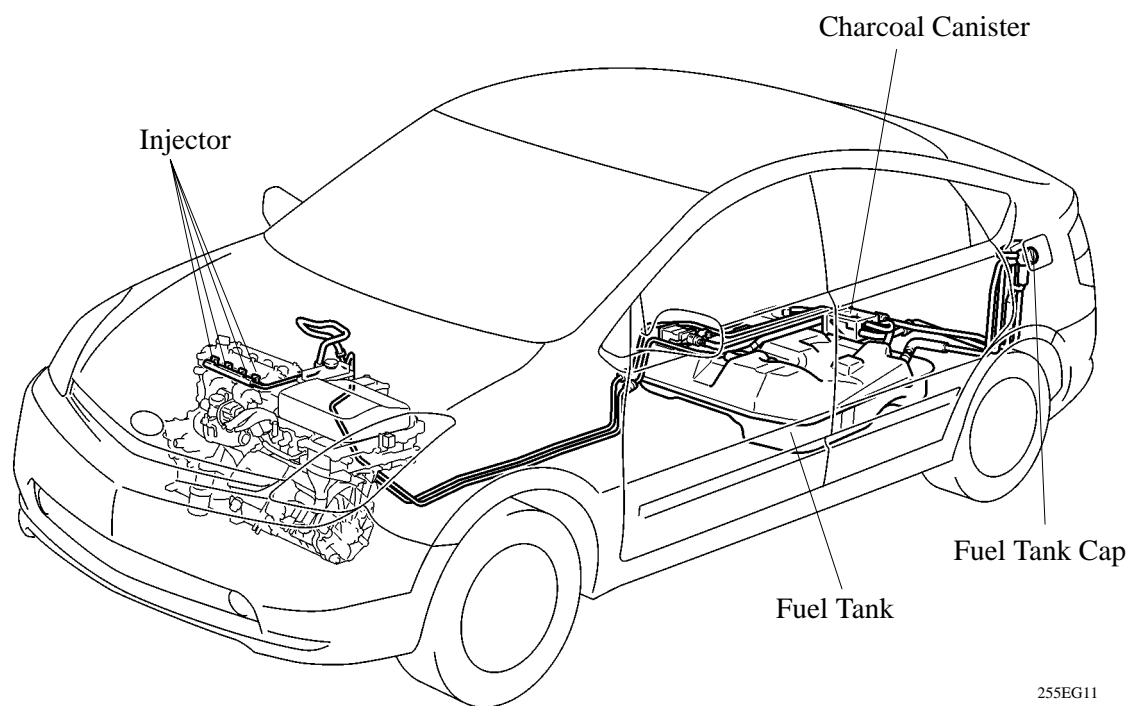

2. ORVR System

- The ORVR (On-Board Refueling Vapor Recovery) is a system that uses a charcoal canister, which is provided onboard, to recover the fuel vapor that is generated during refueling. This reduces the discharge of fuel vapor into the atmosphere.
- On the '04 Prius, the fresh air line inlet has been relocated from the air cleaner to the vicinity of the fuel inlet.

