

■ INTAKE AND EXHAUST SYSTEM

1. General

- The ETCS-i (Electronic Throttle Control System-intelligent) continues to be used from the '03 Prius.
- The link-less type throttle body is used.
- A carbon filter, which absorbs the HC that accumulates in the intake system when the engine is stopped, has been adopted in the air cleaner cap.
- A resonator has been provided at the air cleaner inlet in order to reduce the air intake noise.
- The shape of the exhaust manifold has been changed and its wall thickness has been reduced in order to improve the warm-up performance of the TWC (Three-Way Catalytic Converter) and weight reduction.
- The Toyota HCAC (HC Adsorber and Catalyst) system has been discontinued. Accordingly, the HC adsorber in the No. 2 TWC has been discontinued.

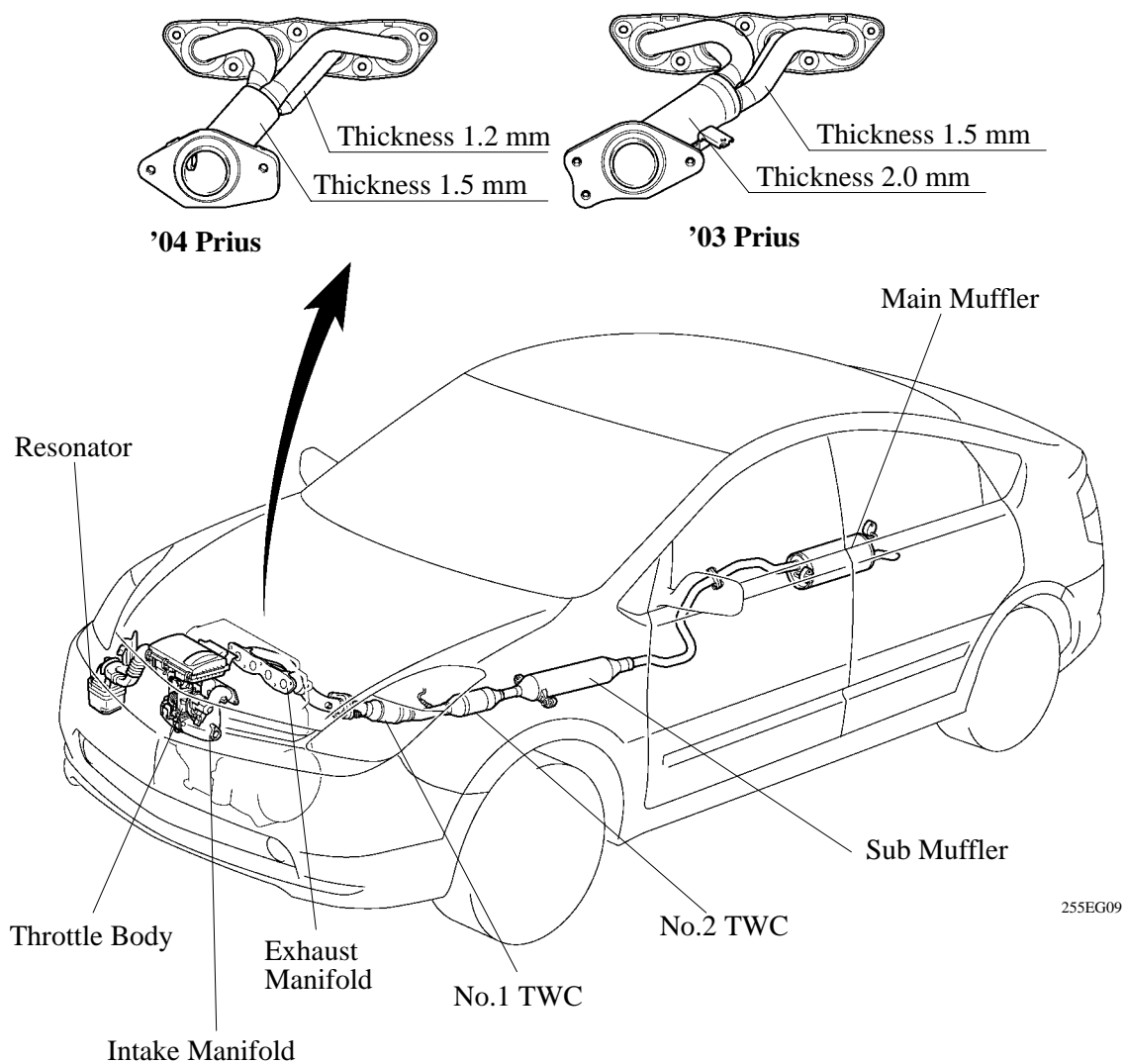

2. Air Cleaner

A carbon filter, which adsorbs the HC that accumulates in the intake system when the engine is stopped, has been adopted in the air cleaner cap in order to reduce evaporative emissions. This filter is maintenance-free.

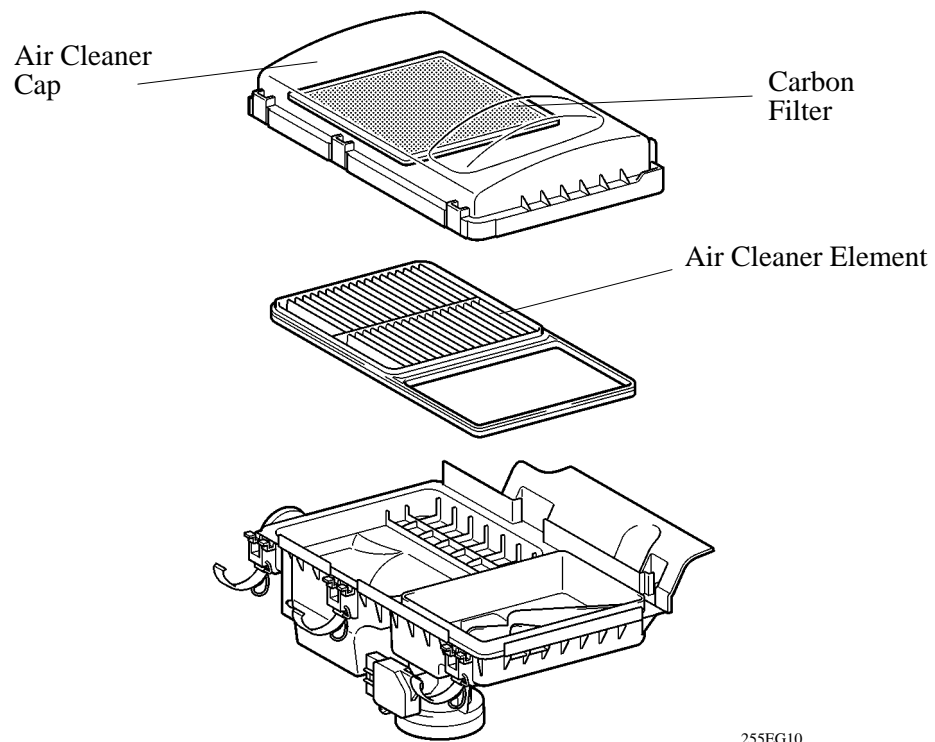

255EG10