

# Smart Entry System and Wireless Door Lock Control

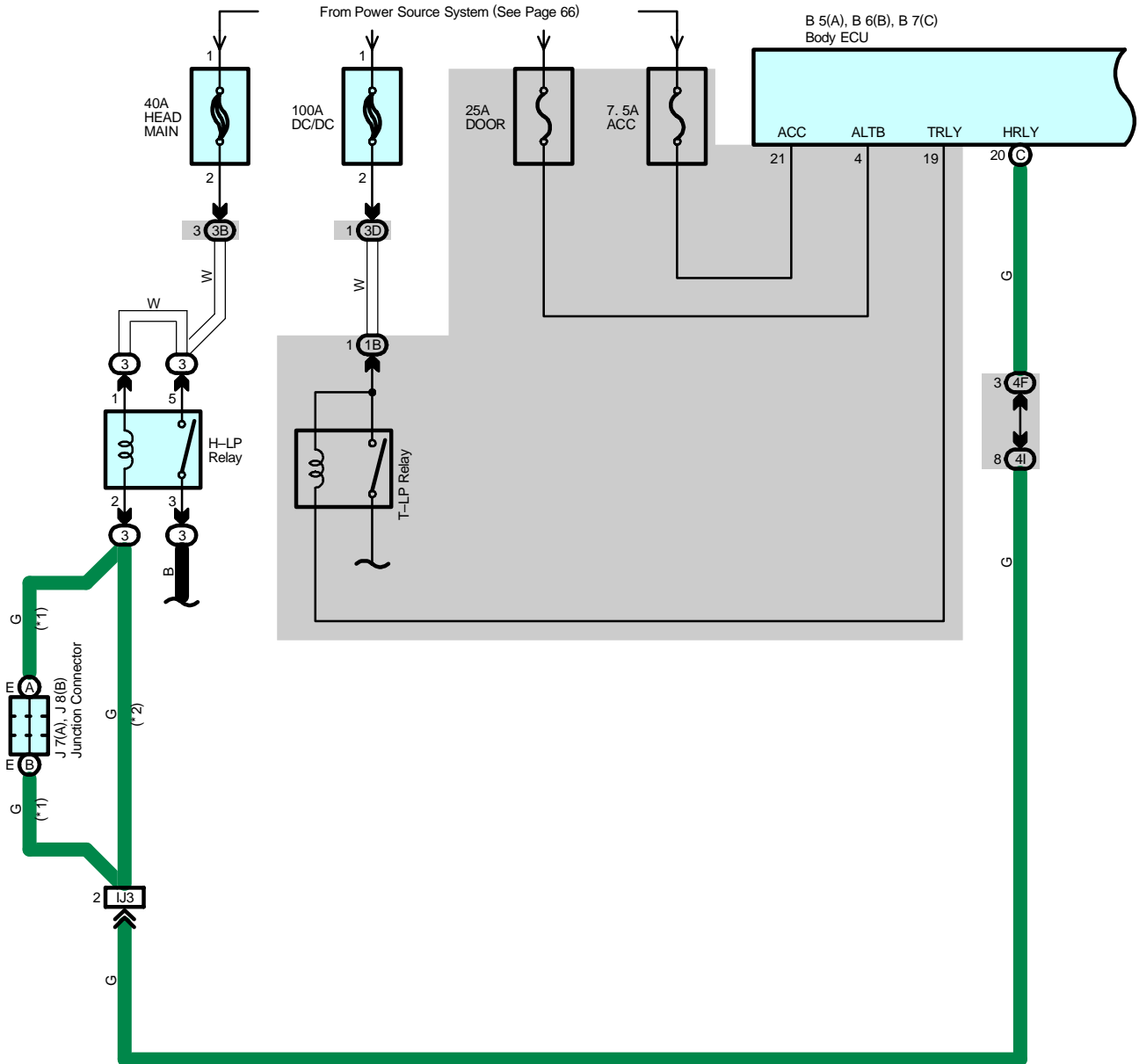

\* 1 : w/ HID  
 \* 2 : w/o HID

B 5(A), B 6(B), B 7(C)  
Body ECU

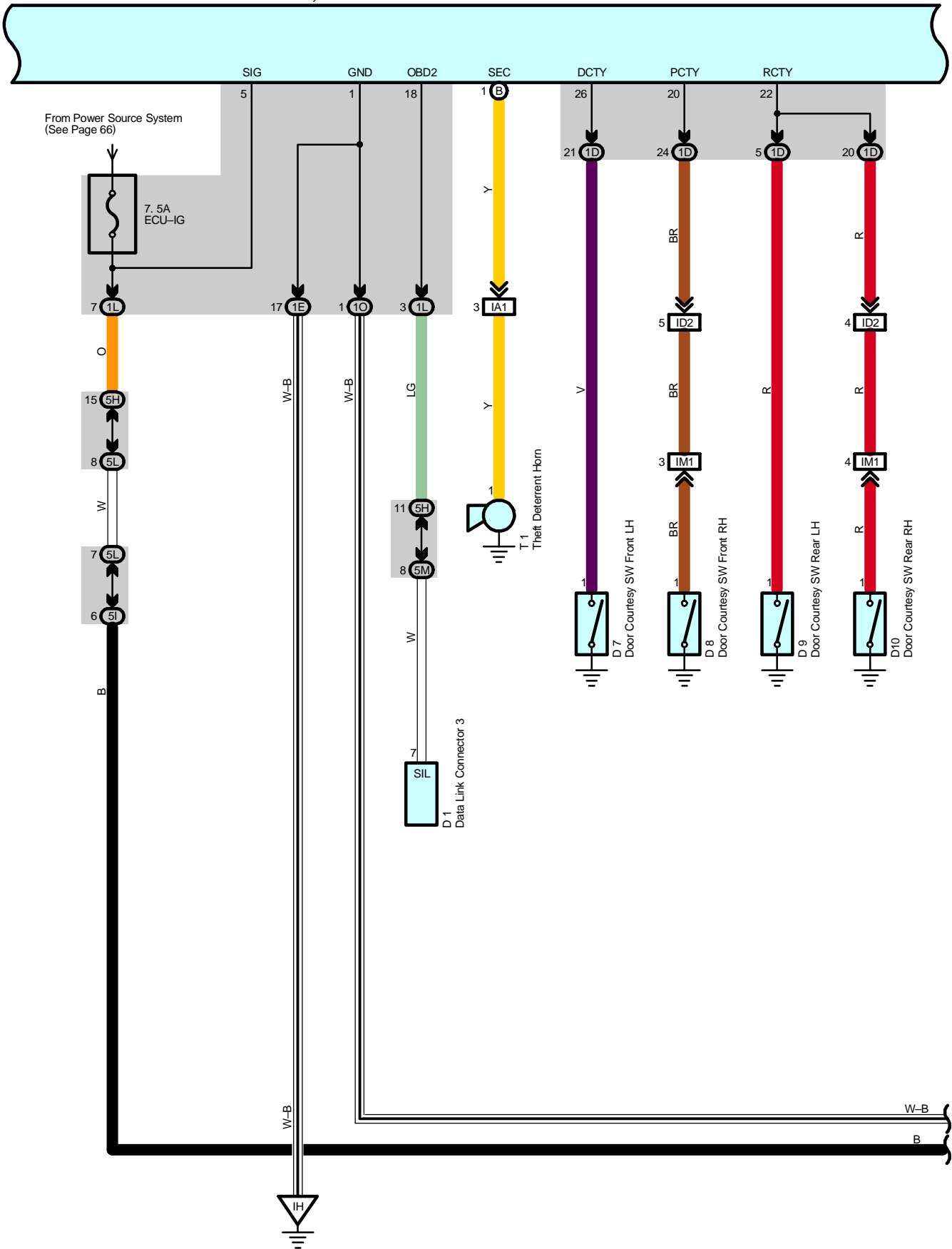

# Smart Entry System and Wireless Door Lock Control

B 5(A), B 6(B), B 7(C)  
Body ECU

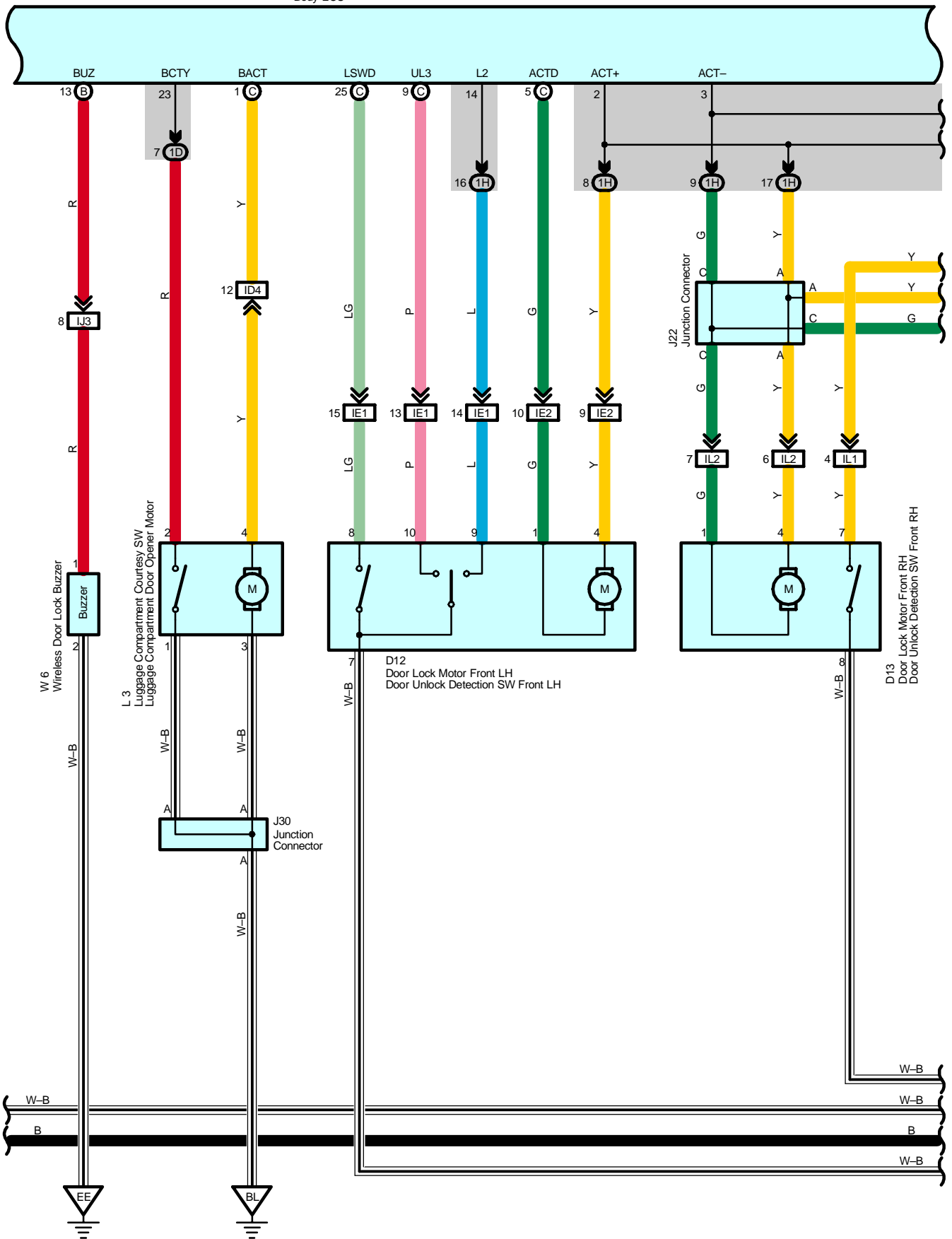

B 5(A), B 6(B), B 7(C)  
Body ECU

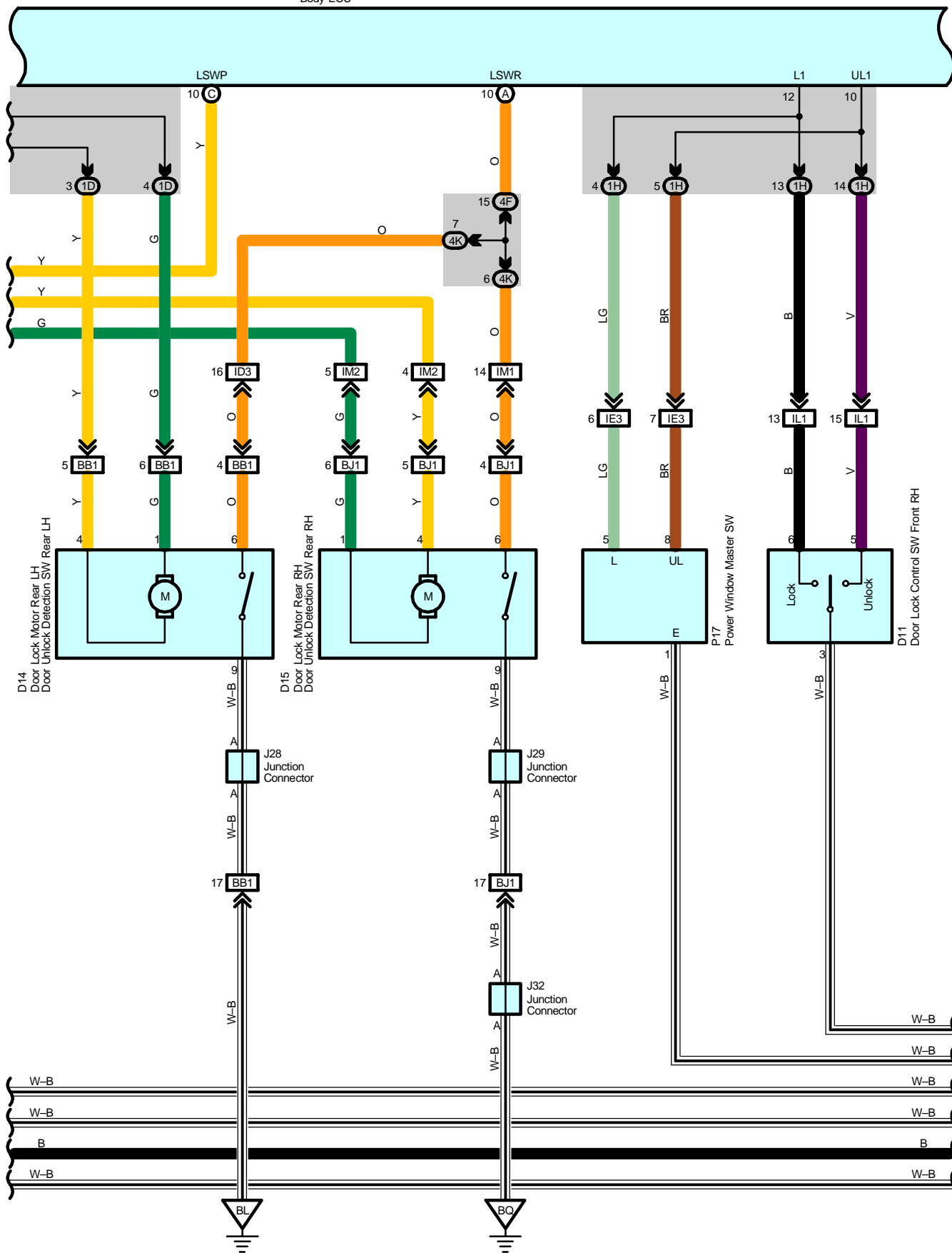

# Smart Entry System and Wireless Door Lock Control

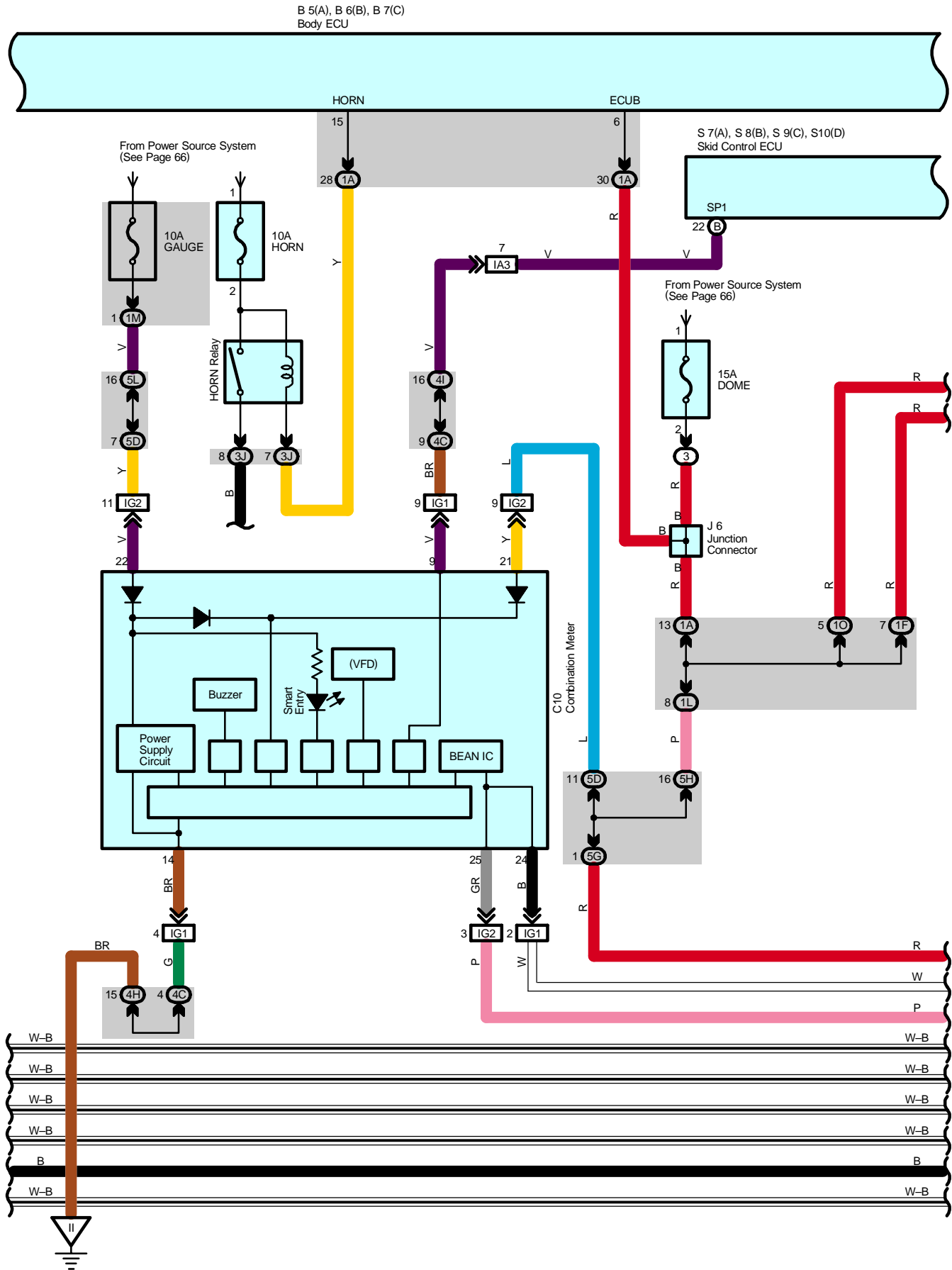

B 5(A), B 6(B), B 7(C)  
Body ECU

S 7(A), S 8(B), S 9(C), S10(D)  
Skid Control ECU

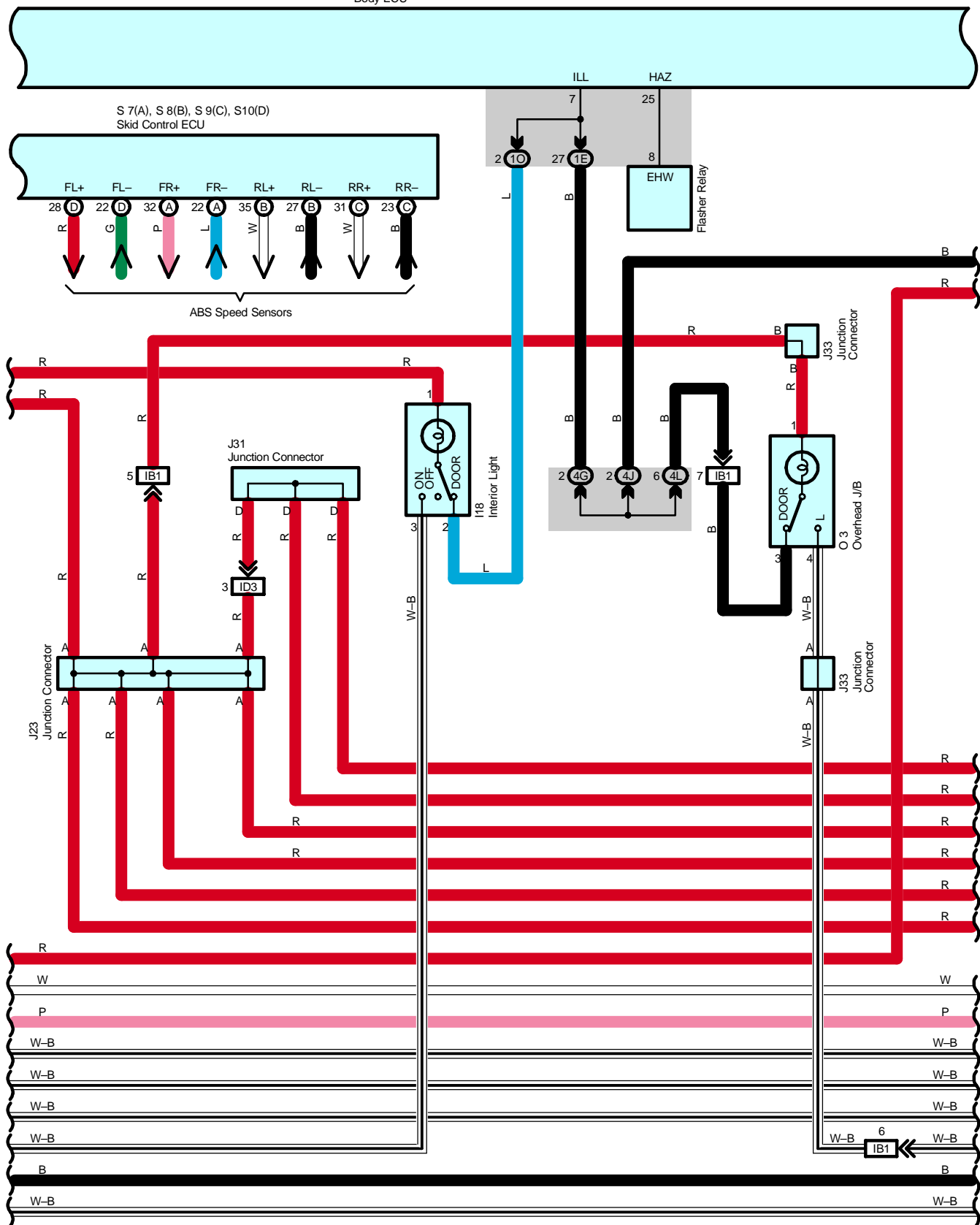

# Smart Entry System and Wireless Door Lock Control

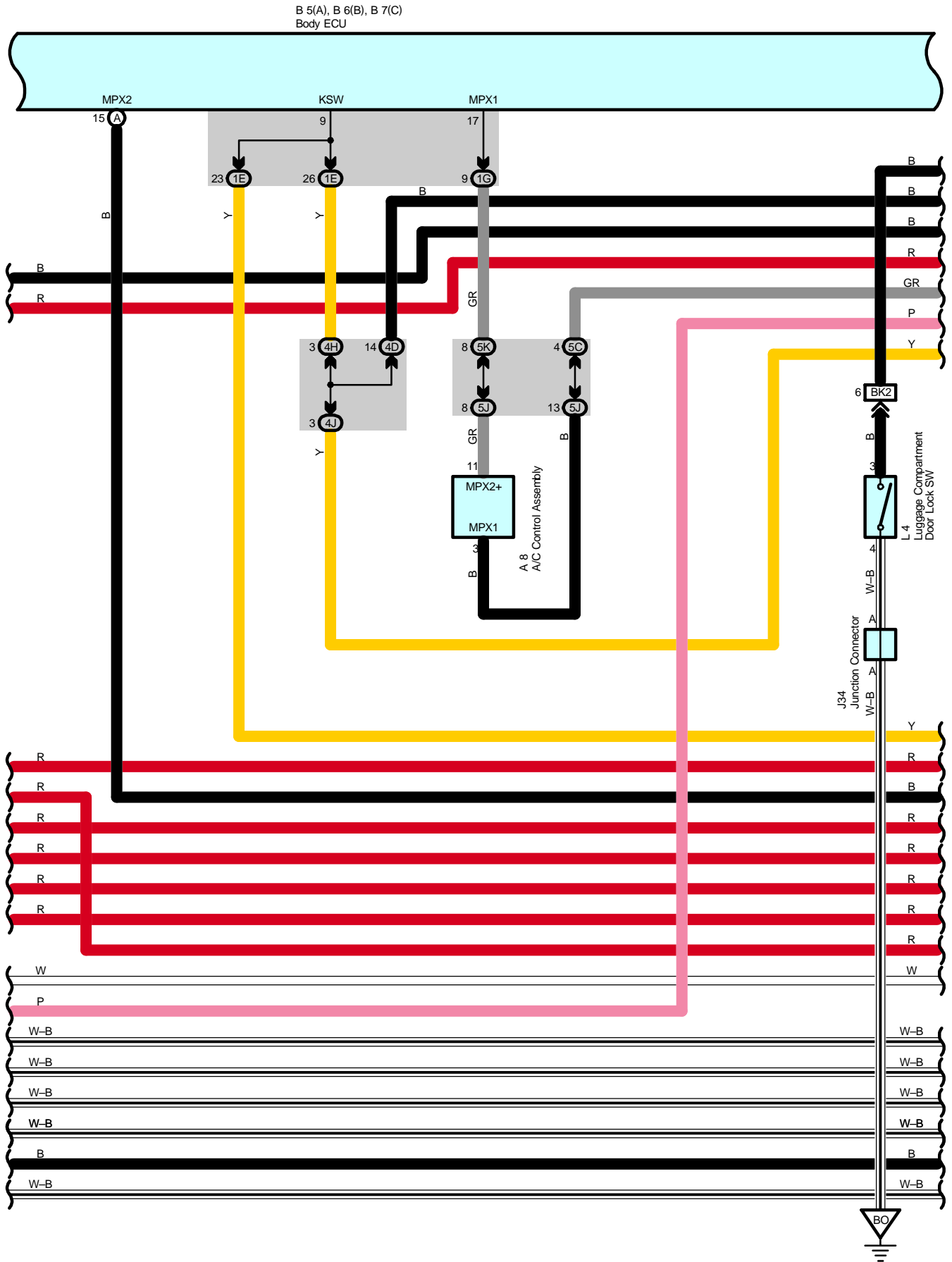

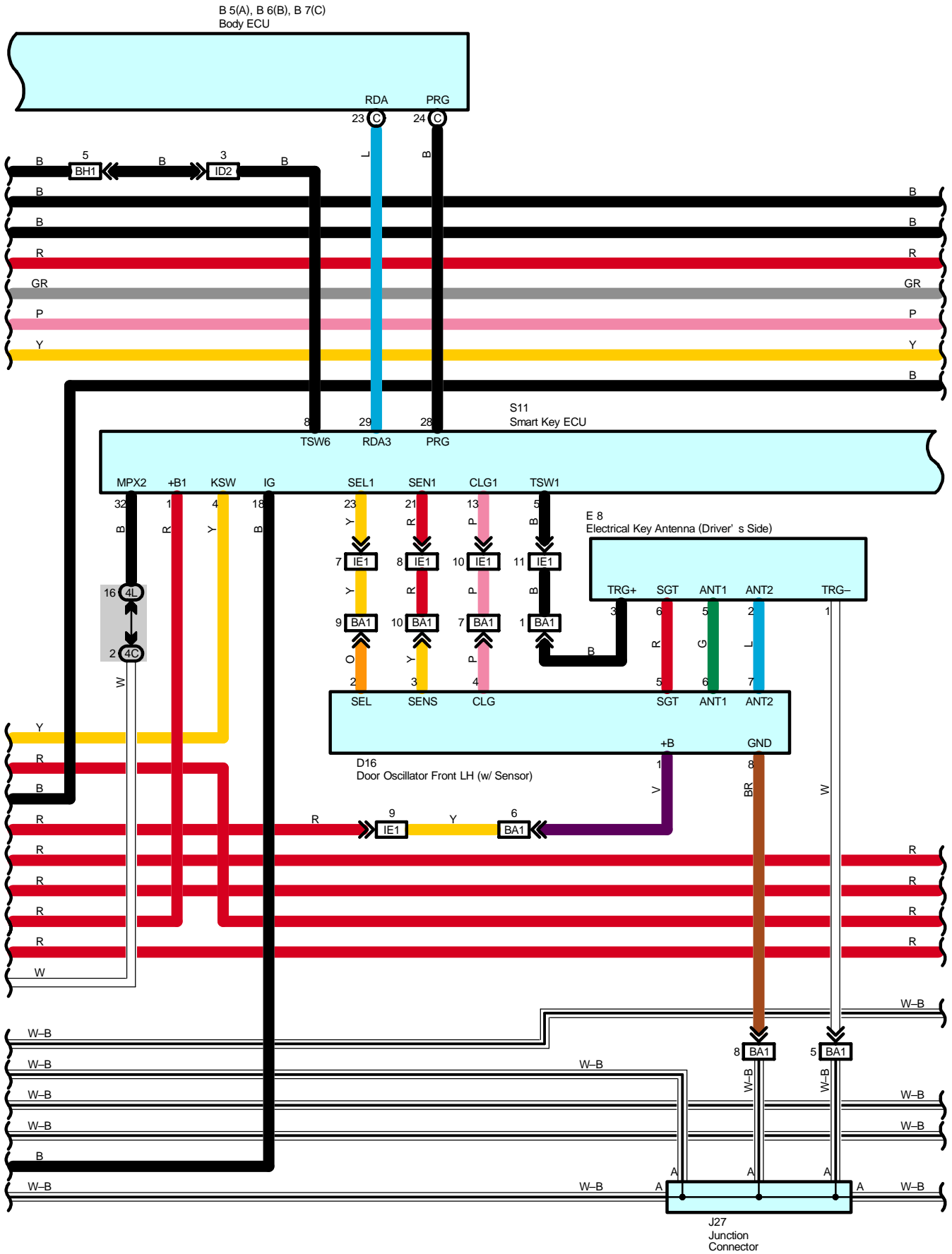



# Smart Entry System and Wireless Door Lock Control

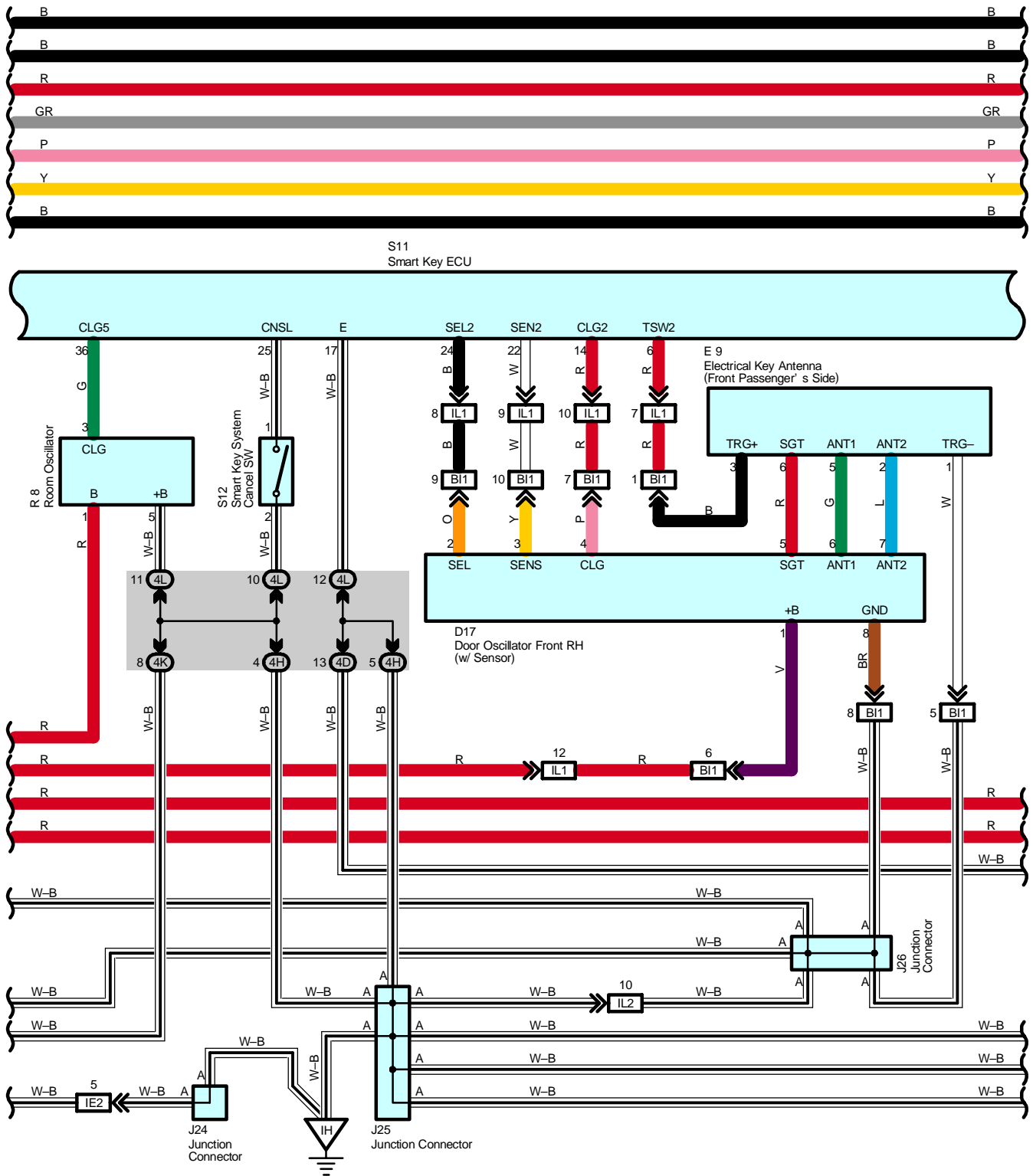

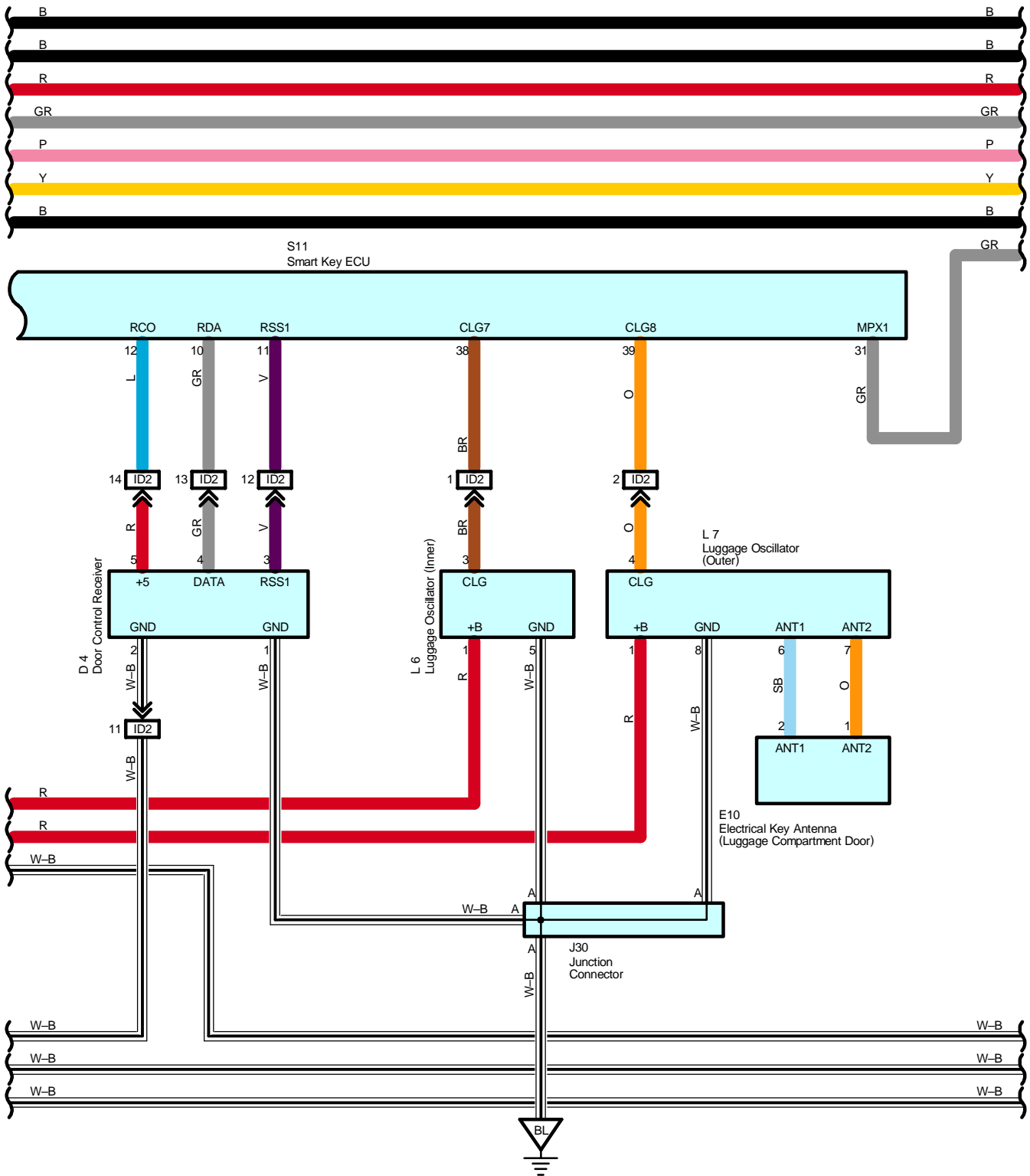

# Smart Entry System and Wireless Door Lock Control

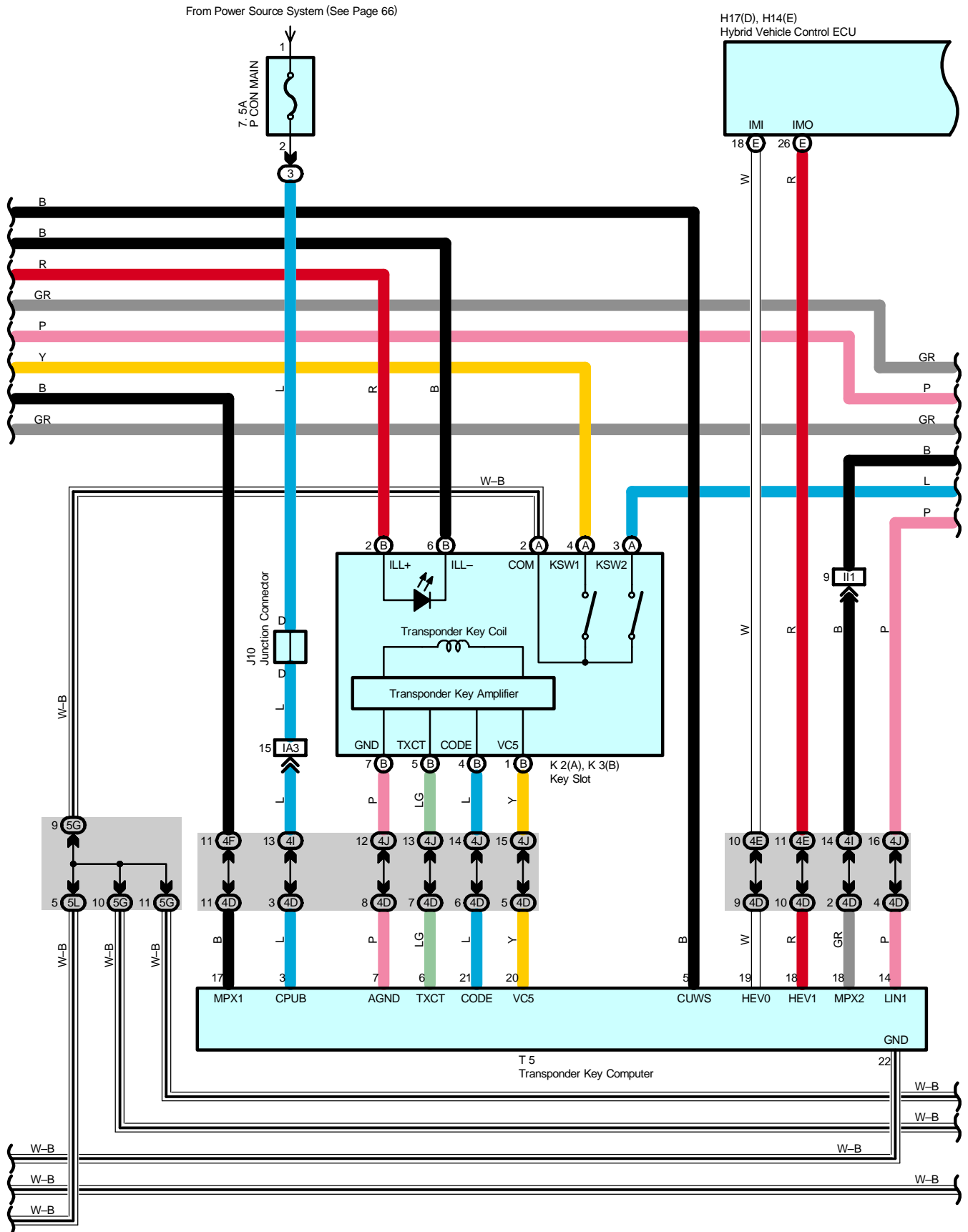

H17(D), H14(E)  
Hybrid Vehicle Control ECU

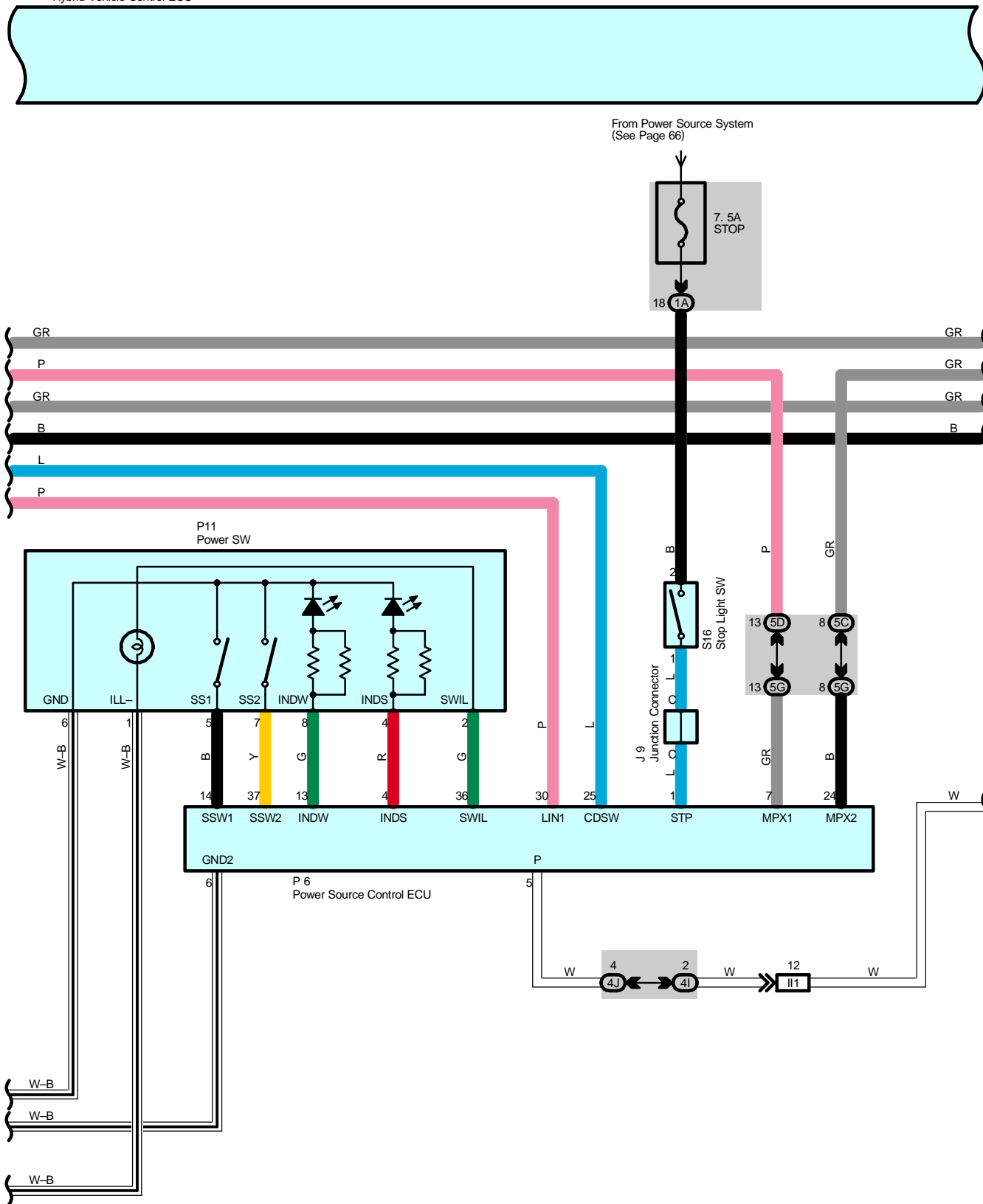

# Smart Entry System and Wireless Door Lock Control

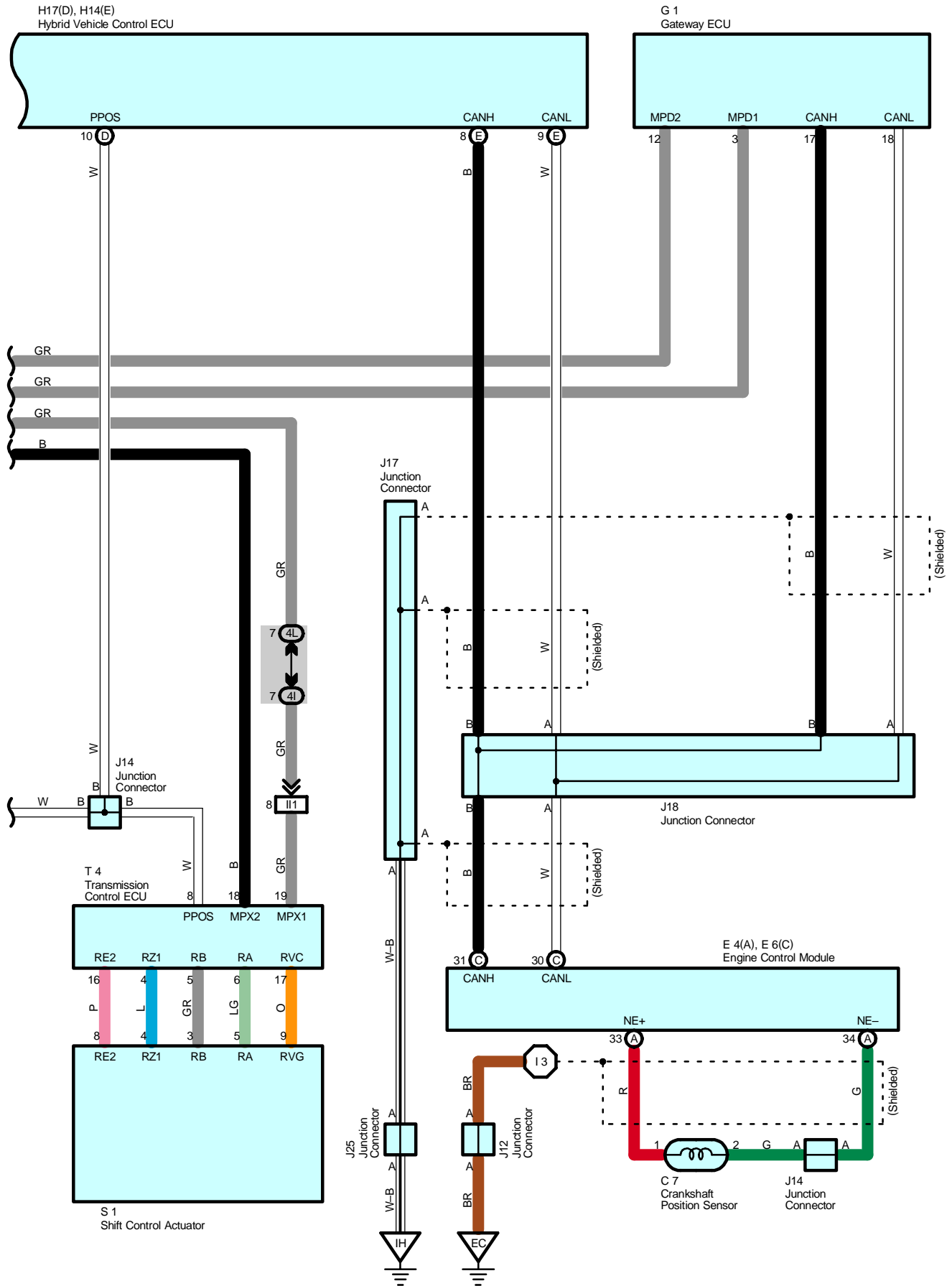

## System Outline

Smart entry system is a system to enable, without operating the key, to lock/unlock doors, to unlatch luggage compartment door, to start engine (Motor). It owes interactive communication function of electrical key, which makes the vehicle to recognize where the key is. All that driver has to do is to have the key with him or her. If the electrical key runs out of dry battery, the key operates as normal key without the smart key system.

### 1. Smart Door Unlock Function

When all the doors are locked, oscillator of each door sends signal regularly and forms detecting area outside of passenger room around 0.7 to 1m from each door handle. After forming the area, driver goes in the area with the electrical key, the key sends ID code signal. Smart key ECU receives the signal through electrical key antenna and identifies ID code. After identifying ID code, doors in the area get into unlock stand-by condition. At this time, sensors installed in door handles activate. Touching back of door handles unlocks the door locks, lights up hazard lamp and sounds wireless door lock buzzer (Except European vehicles). If any door is not opened within 30 seconds after unlocking the door lock, the doors lock again.

### 2. Smart Door Lock Function

If driver gets off the vehicle with the electrical key and pushes lock SW of door handles when all doors are locked, smart key ECU sends signal to inside and outside of passenger room to identify the electrical key. In case identification with inside of the passenger room is NG and that with outside of it is OK, doors lock. Door ajar alarm sounds to tell a door is not shut properly when lock SW of door handle is pushed with any door opened.

### 3. Smart Luggage Compartment Door Unlatch Function

If the driver stands in front of luggage compartment door with the electrical key and pushes unlock SW of luggage compartment door, ID code of the electrical key is identified with smart key ECU through luggage oscillator (Outer). After the ID code is identified, luggage compartment door is unlocked. To keep pushing luggage compartment door opener SW unlatches luggage compartment door.

### 4. Smart Ignition (READY) Function

When the driver pushes the power SW with the electrical key with him or her, ID code of the electrical key is identified with smart key ECU by room oscillator in passenger room. After the ID code is identified, hybrid vehicle immobilizer is released and electric power is set at ACC ON to enable to start engine. Then pushing the power SW sets power supply at IG ON and another pushing sets it at OFF. Condition circulates from ACC ON to/from IG ON to/from OFF and to ACC ON. The vehicle gets READY to drive when the driver pushes power SW with applying brake pedal at any power supply condition.

### 5. Smart Alarm Function

- \* If any door is opened and then shut with shift at P range and the power SW at other than OFF position, smart key ECU identifies ID code with inside of passenger room twice. In case the identification result is NG, buzzer in combination meter alarms (Once) and wireless door lock buzzer alarms (Three times), and smart warning light in combination meter lights up. If power supply is pushed OFF with power SW or identification of the electrical key with inside of passenger room is confirmed at the second time, the warning stops.
- \* If all the doors are closed with shift at P range and power SW at other than OFF position, pushing lock SW of door handle starts smart key ECU to identify ID code with inside and outside of passenger room. In case result of identification with inside is NG and that with outside is confirmed, wireless door lock buzzer alarms (For two seconds) and doors do not lock.
- \* If driver's side door is opened and then shut with shift at other than P range and power SW at other than OFF position, smart key ECU identifies ID code with inside of passenger room twice. In case the identification result is NG, buzzer in combination meter and wireless door lock buzzer alarm continuously as well as smart warning light in combination meter lights up. Then, if shift is put into P range or the identification with inside is confirmed at the second time, the continuous alarming stops. If the driver turns electric power OFF with power SW or the identification with inside is confirmed at the second time, smart warning light goes off.
- \* If other doors than driver's side door is opened and then shut with shift at other than P range and power SW at other than OFF position, smart key ECU identifies ID code with inside of passenger room twice. In case the identification result is NG, buzzer in combination meter alarms (Once) and wireless door lock buzzer alarms (Three times), and smart warning light in combination meter lights up. If power supply is pushed OFF with power SW or identification with inside of passenger room is confirmed at the second time, the warning stops.
- \* If lock SW of door handle is pushed with all the doors shut and power SW at OFF position, smart key ECU identifies ID code with inside of passenger room twice. In case the identification is confirmed then, wireless door lock buzzer alarms (For two seconds) but doors do not lock.
- \* If power supply is turned OFF with power SW after "READY to drive" condition are kept for about 20 minutes, smart key ECU identifies ID code of the electrical key with inside of passenger room. In case the ECU recognizes code of battery voltage decrease, buzzer in combination meter alarms once.
- \* If power SW is pushed ON, smart key ECU identifies ID code with inside of passenger room twice. In case the identification result is NG, buzzer in combination meter alarms once and smart warning light lights up for about five seconds. Then, driver's operation of power SW is cancelled.

# Smart Entry System and Wireless Door Lock Control

## 6. Smart Door Unlock Mode Change Function

If lock button and PANIC button of electrical key are pushed simultaneously for about five seconds with power SW at off position and electrical key not in key holder, smart door unlock mode changes to all door unlock mode or to each door unlock mode (At front passenger door, it changes only to all door unlock condition). The unlock modes circulate. Wireless door lock buzzer and buzzer in combination meter sound to inform mode change.

## 7. Power Saving Function for Battery

In case the electrical key does not send signal for five days or longer, interval between identification time is extended from about 300 ms to 600 ms.

In case the electrical key does not send signal for 14 days or longer, or the key is in detected area outside of vehicle for ten minutes or longer, smart function stops its operation. Smart function resumes under following conditions.

- \* When lock and unlock signal of wireless function of the key is input and its ID code is identified.
- \* When doors are locked with lock SW ON.
- \* When doors are locked or unlocked with door key SW operation.

## 8. Manual Operation Function

Electrical key has lock, unlock, and PANIC buttons. It can operate wireless door locking manually. Its operation is the same as one without smart key system.

## 9. Smart Illumination Function

When driver goes in detected area outside of passenger room with electrical key with him or her and its ID code is identified, interior light, overhead J/B, power SW and key slot light up for about 15 seconds by timer.

## 10. Smart Entry System Cancelled

Smart key system is cancelled under following conditions.

- \* When smart key system cancel SW is turned on.
- \* When electrical key is inserted in key slot.
- \* When battery of electrical key is dead.

## Service Hints

### S11 Smart Key ECU

- 1-Ground : Always approx. 12 volts
- 18-Ground : Approx. 12 volts with the power SW at IG ON position
- 17-Ground : Always continuity
- 25-Ground : Continuity with the smart key system cancel SW at ON position

**○ : Parts Location**

| Code   | See Page | Code    | See Page | Code    | See Page |
|--------|----------|---------|----------|---------|----------|
| A8     | 46       | H14   E | 47       | K2   A  | 48       |
| B5   A | 46       | H17   D | 47       | K3   B  | 48       |
| B6   B | 46       | I18     | 51       | L3      | 51       |
| B7   C | 46       | J6      | 48       | L4      | 51       |
| C7     | 44       | J7   A  | 48       | L6      | 51       |
| C10    | 47       | J8   B  | 48       | L7      | 51       |
| D1     | 47       | J9      | 48       | O3      | 52       |
| D4     | 50       | J10     | 48       | P6      | 49       |
| D7     | 50       | J12     | 48       | P11     | 49       |
| D8     | 50       | J14     | 48       | P17     | 52       |
| D9     | 50       | J17     | 48       | R8      | 49       |
| D10    | 50       | J18     | 48       | S1      | 45       |
| D11    | 50       | J22     | 48       | S7   A  | 49       |
| D12    | 50       | J23     | 48       | S8   B  | 49       |
| D13    | 50       | J24     | 48       | S9   C  | 49       |
| D14    | 50       | J25     | 48       | S10   D | 49       |
| D15    | 50       | J26     | 51       | S11     | 49       |
| D16    | 50       | J27     | 51       | S12     | 49       |
| D17    | 50       | J28     | 51       | S16     | 49       |
| E4   A | 47       | J29     | 51       | T1      | 45       |
| E6   C | 47       | J30     | 51       | T4      | 49       |
| E8     | 51       | J31     | 51       | T5      | 49       |
| E9     | 51       | J32     | 51       | W6      | 45       |
| E10    | 51       | J33     | 51       |         |          |
| G1     | 47       | J34     | 51       |         |          |

**○ : Relay Blocks**

| Code | See Page | Relay Blocks (Relay Block Location)       |
|------|----------|---|
| 3    | 22       | Engine Room R/B (Engine Compartment Left) |



# Smart Entry System and Wireless Door Lock Control

## : Junction Block and Wire Harness Connector

| Code | See Page | Junction Block and Wire Harness (Connector Location)                           |
|------|----------|--|
| 1A   | 28       | Engine Room Main Wire and Driver Side J/B (Lower Finish Panel)                 |
| 1B   |          |  |
| 1D   | 28       | Floor Wire and Driver Side J/B (Lower Finish Panel)                            |
| 1E   | 28       | Instrument Panel Wire and Driver Side J/B (Lower Finish Panel)                 |
| 1F   |          |  |
| 1G   |          |  |
| 1H   |          |  |
| 1L   |          |  |
| 1M   |          |  |
| 1O   | 28       | Roof Wire and Driver Side J/B (Lower Finish Panel)                             |
| 3B   | 22       | Engine Room Main Wire and Engine Room J/B (Engine Compartment Left)            |
| 3D   |          |  |
| 3J   |          |  |
| 4C   | 36       | Instrument Panel Wire and Center Connector No.1 (Behind the Combination Meter) |
| 4D   |          |  |
| 4E   |          |  |
| 4F   |          |  |
| 4G   |          |  |
| 4H   |          |  |
| 4I   |          |  |
| 4J   |          |  |
| 4K   |          |  |
| 4L   |          |  |
| 5C   | 40       | Instrument Panel Wire and Center Connector No.2 (Instrument Panel Brace RH)    |
| 5D   |          |  |
| 5G   |          |  |
| 5H   |          |  |
| 5I   |          |  |
| 5J   |          |  |
| 5K   |          |  |
| 5L   |          |  |
| 5M   |          |  |

 : **Connector Joining Wire Harness and Wire Harness**

| Code | See Page | Joining Wire Harness and Wire Harness (Connector Location)                            |
|------|----------|---|
| IA1  | 56       | Engine Room Main Wire and Instrument Panel Wire (Upper Parts of Front Body Pillar LH) |
| IA3  |          |   |
| IB1  | 56       | Roof Wire and Instrument Panel Wire (Upper Parts of Front Body Pillar LH)             |
| ID2  | 56       | Instrument Panel Wire and Floor Wire (Left Kick Panel)                                |
| ID3  |          |   |
| ID4  |          |   |
| IE1  | 56       | Front Door LH Wire and Instrument Panel Wire (Left Kick Panel)                        |
| IE2  |          |   |
| IE3  |          |   |
| IG1  | 58       | Instrument Panel Wire and Instrument Panel No.2 Wire (Behind the Combination Meter)   |
| IG2  |          |   |
| II1  | 58       | Engine Wire and Instrument Panel Wire (Behind the Glove Box)                          |
| IJ3  | 58       | Engine Room Main Wire and Instrument Panel Wire (Behind the Glove Box)                |
| IL1  | 58       | Front Door RH Wire and Instrument Panel Wire (Right Kick Panel)                       |
| IL2  |          |   |
| IM1  | 58       | Instrument Panel Wire and Floor No.2 Wire (Right Kick Panel)                          |
| IM2  |          |   |
| BA1  | 60       | Front Door LH Wire and Electrical Key LH Wire (Near the Front Door Outside Handle LH) |
| BB1  | 60       | Rear Door No.2 Wire and Floor Wire (Left Center Pillar)                               |
| BH1  | 62       | Back Door No.1 Wire and Floor Wire (Rear Side of Roof Panel)                          |
| BI1  | 62       | Front Door RH Wire and Electrical Key RH Wire (Near the Front Door Outside Handle RH) |
| BJ1  | 62       | Rear Door No.1 Wire and Floor No.2 Wire (Right Center Pillar)                         |
| BK2  | 62       | Back Door No.1 Wire and Back Door No.2 Wire (Rear Side of Roof Panel)                 |

 : **Ground Points**

| Code | See Page | Ground Points Location            |
|------|----------|-----------------------------------|
| EC   | 54       | Engine Block                      |
| EE   | 54       | Left Side of the Suspension Tower |
| IH   | 56       | Cowl Side Panel LH                |
| II   | 56       | Instrument Panel Brace LH         |
| BL   | 60       | Rear Side of Left Quarter Panel   |
| BO   | 60       | Center of the Back Door Panel     |
| BQ   | 60       | Rear Side of Right Quarter Panel  |

 : **Splice Points**

| Code | See Page | Wire Harness with Splice Points | Code | See Page | Wire Harness with Splice Points |
|------|----------|---------------------------------|------|----------|---------------------------------|
| I3   | 58       | Engine Wire                     |      |          |                                 |