

DTC	P2601	COOLANT PUMP CONTROL CIRCUIT RANGE/PERFORMANCE
------------	--------------	---

HINT:

- CHS stands for Coolant Heat Storage.
- Although the DTC title says "Coolant Pump", this DTC is related to the CHS water pump.

CIRCUIT DESCRIPTION

The coolant heat storage system uses an electric pump to supply hot coolant stored in the CHS tank into the cylinder head of the engine, in order to optimize engine starting combustion and reduce the amount of unburned gas that is discharged while the engine is started. Before the engine starts, the ECM operates the electric water pump to direct the hot coolant in the CHS tank into the engine, in order to heat the cylinder head (this process is called "preheat mode"). This system consists of the CHS tank, CHS water pump, CHS tank outlet temperature sensor, water valve, and a soak timer that is built in the ECM.

DTC No.	DTC Detecting Condition	Trouble Area
P2601	Following conditions are successively met: <ul style="list-style-type: none"> • Difference in CHS tank outlet water temperature and engine coolant temperatures before and after starting preheating: below 2°C (3.6 °F) • Change in CHS tank outlet water temperature during soaking: Within 1°C (1.8 °F) of its temperature before CHS water pump is ON 	<ul style="list-style-type: none"> • CHS water pump • CHS water pump relay • Open or short in CHS water pump circuit • ECM

MONITOR DESCRIPTION

The ECM detects malfunction in the coolant heat storage (CHS) system with the CHS tank coolant temperature, the position of the water valve, the running condition of the engine and the operating condition of the soak timer.

The soak timer built in the ECM prompts the ECM to actuate the water pump 5 hours after the HV system has been turned OFF by using the power switch. The ECM then checks the HV main system based on variations in the CHS tank outlet temperature (soak mode).

In order to ensure the reliable malfunction detection, the ECM detects the CHS water pump malfunction DTC in two ways. Thus, when the following two detection conditions are consecutively met, the ECM determines that there is malfunction in the water pump circuit and sets the DTC.

- (1) Difference in the CHS tank outlet temperature and the engine coolant temperature before and after starting preheating at engine start (system start) is below 2 °C (3.6 °F).
- (2) Variation in the CHS tank outlet temperature during soak mode is within 1 °C (1.8 °F) of its temperature before the CHS water pump was ON.

MONITOR STRATEGY

Related DTCs	P2601: Coolant pump control circuit range/performance
Required sensors/components	Coolant heat storage tank outlet temperature sensor
Frequency of operation	Once per driving cycle
Duration	10 seconds
MIL operation	1 driving cycle
Sequence of operation	None

TYPICAL ENABLING CONDITIONS

The monitor will run whenever the following DTCs are not present	See page 05-20
Coolant heat storage system malfunction	Not detected
CHS water pump operation time	3 seconds or more
Variation in CHS tank outlet temperature and engine coolant temperature before and after preheating	2°C (3.6°F) or less
Storage coolant temperature	More than 75°C (167°F)

TYPICAL MALFUNCTION THRESHOLDS

Difference in CHS tank outlet coolant temperature before and after CHS water pump ON	Less than 1°C (1.8°F)
--	-----------------------

WIRING DIAGRAM

Refer to DTC P1120 on page [05-277](#).

INSPECTION PROCEDURE

CAUTION:

Be careful when replacing any part in the CHS system or changing the coolant because the coolant in the CHS tank is hot even if the engine and the radiator are cold.

NOTICE:

If air breeding is not performed completely, this DTC may be detected after changing the coolant.

HINT:

- The detection of this DTC indicates a malfunction in both the CHS water pump and the CHS W/P relay. Therefore, make sure to also check the relay when this DTC is output.
- To check the coolant heat storage (CHS) system, the ECM may cause the water pump of the CHS system to operate 5 hours after the power switch has been turned OFF.
- Read freeze frame data using the hand-held tester or the OBD II scan tool. Freeze frame data records the engine condition when malfunction is detected. When troubleshooting, freeze frame data can help determine if the vehicle was running or stopped, if the engine was warmed up or not, if the air-fuel ratio was lean or rich, and other data from the time the malfunction occurred.

Hand-held tester:

1 | CHECK OTHER DTC OUTPUT(IN ADDITION TO DTC P2601)

- (a) Connect the hand-held tester or the OBD II scan tool to the DLC3.
- (b) Turn the power switch ON (IG).
- (c) Turn the hand-held tester ON.
- (d) On the hand-held tester, select the item: DIAGNOSIS / ENHANCED OBD II / ENGINE AND ECT / DTC INFO / CURRENT CODES.
- (e) Read DTCs using the hand-held tester or the OBD II scan tool.

Result:

Display (DTC Output)	Proceed to
P2601	A
P2601 and other DTCs	B

HINT:

If any other codes besides P2601 are output, perform troubleshooting for those DTCs first.

B ▶ **GO TO RELEVANT DTC CHART**
(See page [05-55](#))

A

2 | PERFORM ACTIVE TEST BY HAND-HELD TESTER(OPERATE WATER PUMP)

- (a) Connect the hand-held tester to the DLC3.
- (b) Turn the power switch ON (IG).
- (c) Turn the hand-held tester ON.
- (d) On the hand-held tester, select the item: DIAGNOSIS / ENHANCED OBD II / ENGINE AND ECT / ACTIVE TEST / WATER PUMP.
- (e) Check that the CHS W/P relay operates and the operating sounds of the water pump occurs.

Standard:

Tester Operation	Specified Condition
WATER PUMP ON	CHS W/P relay and water pump operates

NG ▶ **Go to step 5**

OK

3 INSPECT TEMPERATURE SENSOR (CHS TANK OUTLET TEMPERATURE SENSOR)

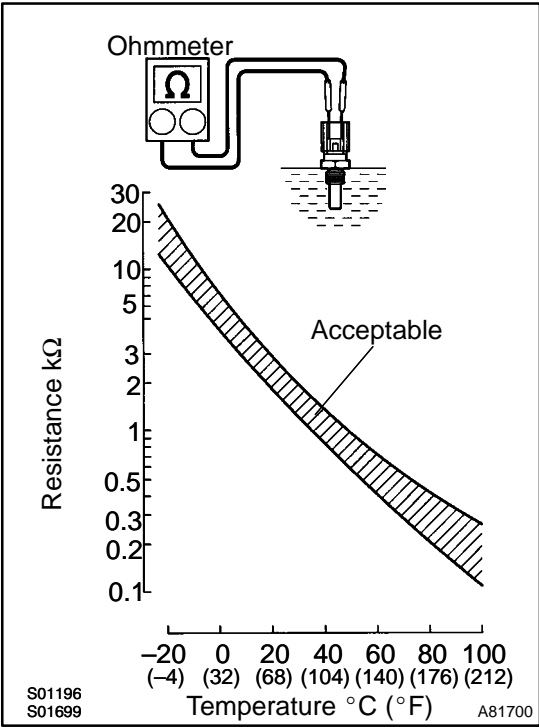

- (a) Remove the coolant heat storage (CHS) tank outlet temperature sensor.
- (b) Measure the resistance between the terminals.

Standard:

Tester Connection	Specified Condition
1 - 2	2 to 3 kΩ at 20°C (68°F)
1 - 2	0.2 to 0.4 kΩ at 80°C (176°F)

NOTICE:

In case of checking the CHS tank outlet temperature sensor in the water, be careful not to allow water to contact the terminals. After checking, dry the sensor.

HINT:

Alternate procedure: Connect an ohmmeter to the installed CHS tank outlet temperature sensor and read the resistance. Use an infrared thermometer to measure the CHS tank outlet temperature in the immediate vicinity of the sensor. Compare these values to the resistance/temperature graph. Change the engine coolant temperature (warm up or allow to cool down) and repeat the test.

- (c) Reinstall the CHS tank outlet temperature sensor.

NG → **REPLACE TEMPERATURE SENSOR**

OK

4 CHECK HARNESS AND CONNECTOR(ECM - CHS TANK OUTLET TEMPERATURE SENSOR)

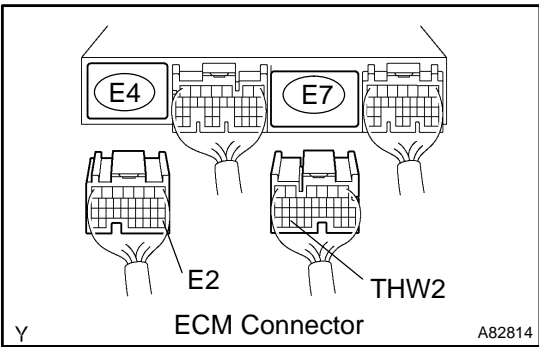
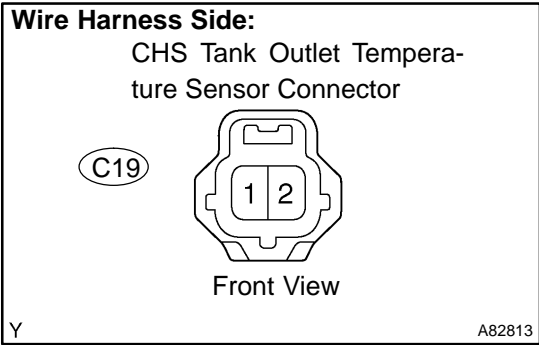

- (a) Check the harness and the connectors between the CHS tank outlet temperature sensor connector and the ECM connector.
- (1) Disconnect the C19 CHS tank outlet temperature sensor connector.
 - (2) Disconnect the E5 and E7 ECM connectors.
 - (3) Check the resistance between the wire harness side connectors.

Standard (Check for open):

Tester Connection	Specified Condition
CHS tank outlet temperature sensor (C19-2) - THW2 (E7-33)	Below 1 Ω
CHS tank outlet temperature sensor (E2-1) - E2 (E4-28)	Below 1 Ω

Standard (Check for short):

Tester Connection	Specified Condition
CHS tank outlet temperature sensor (C19-2) or THW2 (E7-33)- Body ground	10 kΩ or higher

- (4) Reconnect the CHS tank outlet temperature sensor connector.
- (5) Reconnect the ECM connectors.

NG REPAIR OR REPLACE HARNESS OR CONNECTOR

OK

REPLACE ECM (See page 10-24)

5 INSPECT CHS W/P RELAY(CHS WATER PUMP RELAY)

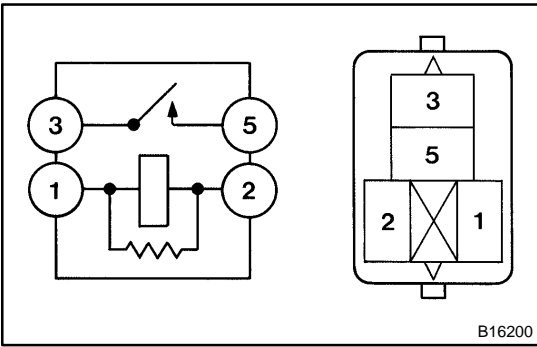

- (a) Remove the CHS W/P relay from the engine room R/B No.2.
- (b) Inspect the CHS W/P relay.

Standard:

Tester Connection	Specified Condition
3 - 5	10 kΩ or higher
3 - 5	Below 1 Ω (Apply battery voltage to terminals 1 and 2)

- (c) Reinstall the CHS W/P relay.

NG → **REPLACE CHS W/P RELAY**

OK

6 INSPECT WATER W/MOTOR & BRACKET PUMP ASSY

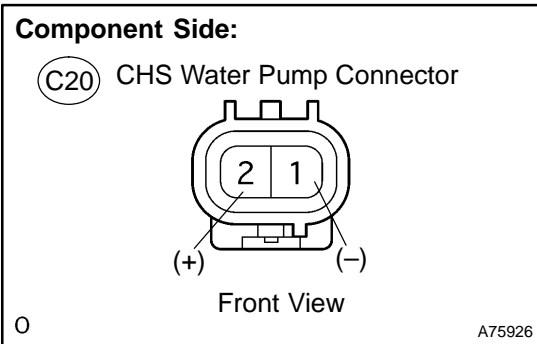

- (a) Disconnect the C20 CHS water pump connector.
- (b) Measure the resistance between the terminals of the water pump.

Standard:

Tester Connection	Specified Condition
1 - 2	0.3 to 100 Ω

- (c) Reconnect the CHS water pump connector.

NG → **REPLACE WATER W/MOTOR & BRACKET PUMP ASSY**

OK

7 CHECK HARNESS AND CONNECTOR(ECM - CHS W/P RELAY, CHS W/P RELAY - WATER PUMP, WATER PUMP - GROUND)

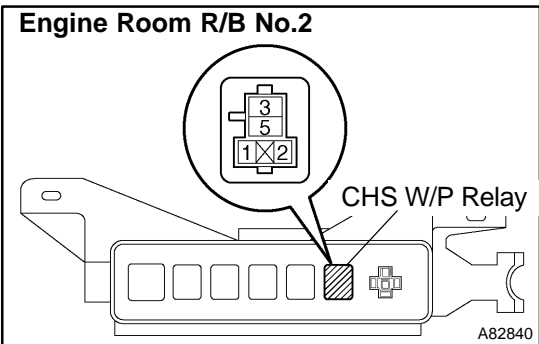
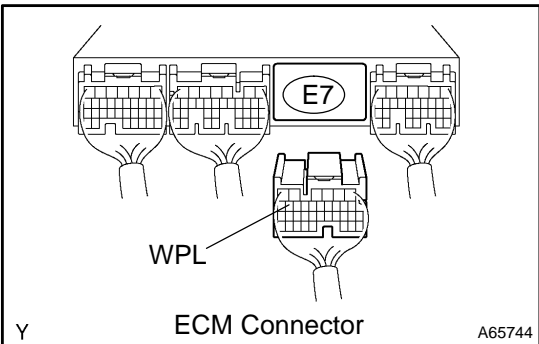
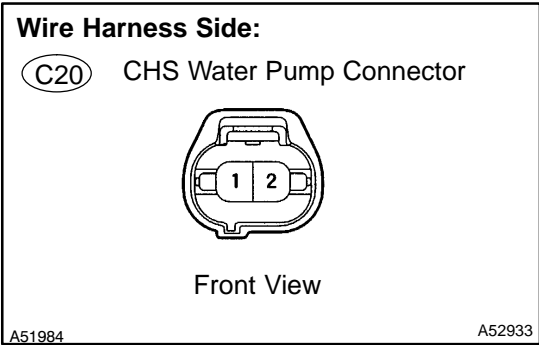

- (a) Check the harness and the connectors between the CHS water pump connector and the ECM connector.
- (1) Remove the CHS W/P relay from the engine room R/B No.2.
 - (2) Disconnect the E7 ECM connector.
 - (3) Check the resistance between the wire harness side connectors.

Standard (Check for open):

Tester Connection	Specified Condition
WPL (E7-15) - CHS W/P relay (2)	Below 1 Ω

Standard (Check for short):

Tester Connection	Specified Condition
CHS W/P relay (2) or WPL (E7-15) - Body ground	10 kΩ or higher

- (4) Reinstall the integration relay.
 - (5) Reconnect the ECM connector.
- (b) Check the harness and the connectors between the CHS water pump connector and the CHS W/P relay.
- (1) Disconnect the CHS water pump connector.
 - (2) Remove the CHS W/P relay from the engine room R/B No.2.
 - (3) Check the resistance between the wire harness side connectors.

Standard (Check for open):

Tester Connection	Specified Condition
CHS water pump (2) - CHS W/P relay (5)	Below 1 Ω
CHS water pump (1) - Body ground	Below 1 Ω

Standard (Check for short):

Tester Connection	Specified Condition
CHS water pump (2) or CHS W/P relay (5) - Body ground	10 kΩ or higher

- (4) Reconnect the CHS water pump connector.
- (5) Reinstall the integration relay.

NG → **REPAIR OR REPLACE HARNESS OR CONNECTOR**

OK

REPLACE ECM (See page 10-24)

OBD II scan tool (excluding hand-held tester):

1 | CHECK OTHER DTC OUTPUT(IN ADDITION TO DTC P2601)

- (a) Connect the OBD II scan tool to the DLC3.
- (b) Turn the power switch ON (IG).
- (c) Turn the OBD II scan tool ON.
- (d) Read the DTCs using the OBD II scan tool.

Result:

Display (DTC Output)	Proceed to
P2601	A
P2601 and other DTCs	B

HINT:

If any other codes besides P2601 are output, perform troubleshooting for those DTCs first.

B **GO TO RELEVANT DTC CHART**
(See page 05-55)

A

2 | INSPECT CHS W/P RELAY(CHS WATER PUMP RELAY)

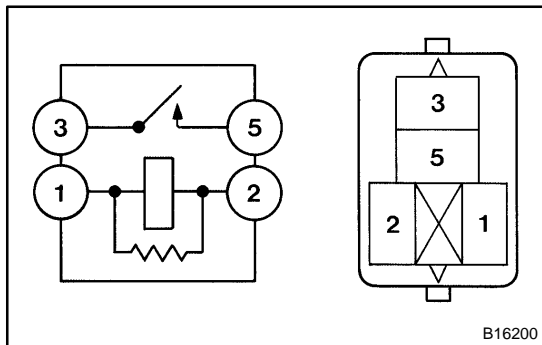

- (a) Remove the CHS W/P relay from the engine room R/B No.2.
- (b) Inspect the CHS W/P relay.

Standard:

Tester Connection	Specified Condition
3 - 5	10 kΩ or higher
3 - 5	Below 1 Ω (Apply battery voltage to terminals 1 and 2)

- (c) Reinstall the CHS W/P relay.

NG **REPLACE CHS W/P RELAY**

OK

3 | INSPECT PUMP ASSY, WATER W/MOTOR & BRACKET

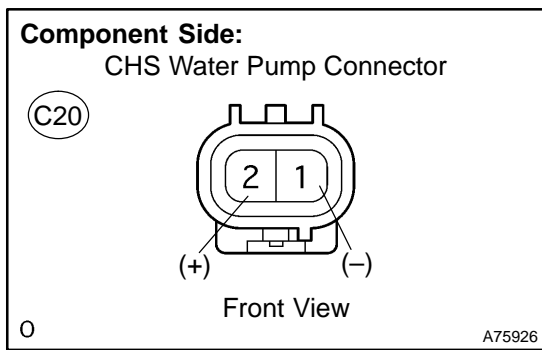

- (a) Disconnect the C20 CHS water pump connector.
- (b) Measure the resistance between the terminals of the water pump.

Standard:

Tester Connection	Specified Condition
1 - 2	0.3 to 100 Ω

- (c) Reconnect the CHS water pump connector.

NG **REPLACE WATER W/MOTOR & BRACKET PUMP ASSY**

OK

4 CHECK HARNESS AND CONNECTOR(ECM - CHS W/P RELAY, CHS W/P RELAY - WATER PUMP, WATER PUMP - GROUND)

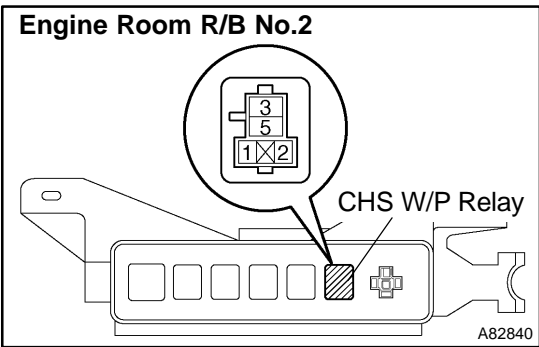
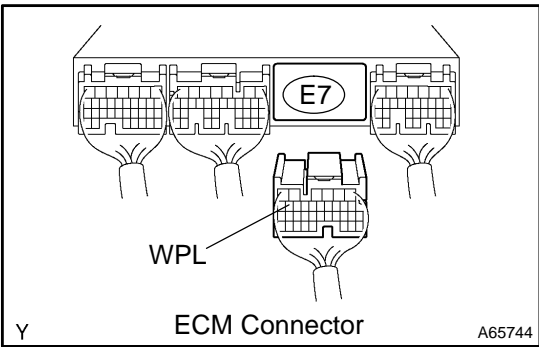
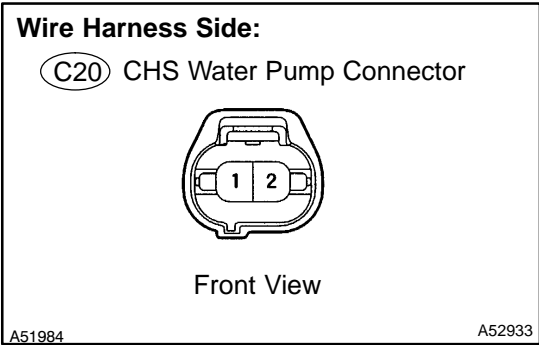

- (a) Check the harness and the connectors between the CHS water pump connector and the ECM connector.
 - (1) Remove the CHS W/P relay from the engine room R/B No.2.
 - (2) Disconnect the E7 ECM connector.
 - (3) Check the resistance between the wire harness side connectors.

Standard (Check for open):

Tester Connection	Specified Condition
WPL (E7-15) - CHS W/P relay (2)	Below 1 Ω

Standard (Check for short):

Tester Connection	Specified Condition
CHS W/P relay (2) or WPL (E7-15) - Body ground	10 kΩ or higher

- (4) Reinstall the integration relay.
 - (5) Reconnect the ECM connector.
- (b) Check the harness and the connectors between the water pump connector and the CHS W/P relay.
 - (1) Disconnect the CHS water pump connector.
 - (2) Remove the CHS W/P relay from the engine room R/B No.2.
 - (3) Check the resistance between the wire harness side connectors.

Standard (Check for open):

Tester Connection	Specified Condition
CHS Water pump (2) - CHS W/P relay (5)	Below 1 Ω
CHS Water pump (1) - Body ground	Below 1 Ω

Standard (Check for short):

Tester Connection	Specified Condition
CHS Water pump (2) or CHS W/P relay (5) - Body ground	10 kΩ or higher

- (4) Reconnect the CHS water pump connector.
 - (5) Reinstall the CHS W/P relay.

NG REPAIR OR REPLACE HARNESS OR CONNECTOR

OK

5 INSPECT TEMPERATURE SENSOR (CHS TANK OUTLET TEMPERATURE SENSOR)

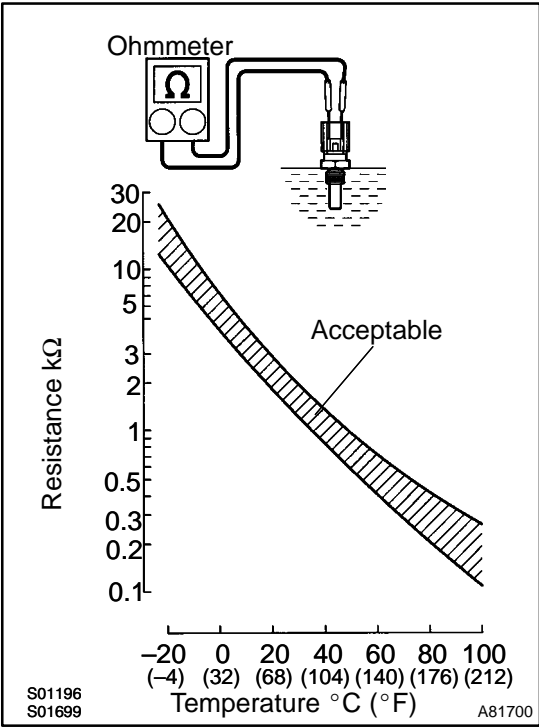

- (a) Remove the coolant heat storage (CHS) tank outlet temperature sensor.
- (b) Measure the resistance between the terminals.

Standard:

Tester Connection	Specified Condition
1 - 2	2 to 3 kΩ at 20°C (68°F)
1 - 2	0.2 to 0.4 kΩ at 80°C (176°F)

NOTICE:

In case of checking the CHS tank outlet temperature sensor in the water, be careful not to allow water to contact the terminals. After checking, dry the sensor.

HINT:

Alternate procedure: Connect an ohmmeter to the installed CHS tank outlet temperature sensor and read the resistance. Use an infrared thermometer to measure the CHS tank outlet temperature in the immediate vicinity of the sensor. Compare these values to the resistance/temperature graph. Change the engine coolant temperature (warm up or allow to cool down) and repeat the test.

- (c) Reinstall the CHS tank outlet temperature sensor.

NG → **REPLACE TEMPERATURE SENSOR**

OK

6 CHECK HARNESS AND CONNECTOR(ECM - CHS TANK OUTLET TEMPERATURE SENSOR)

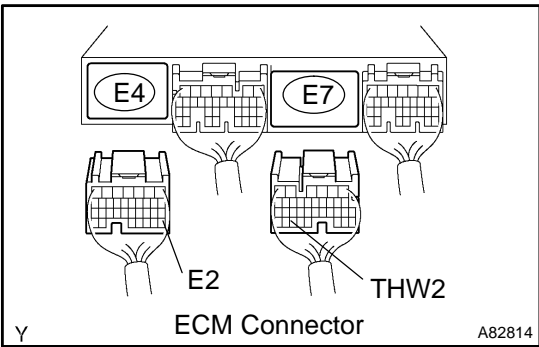
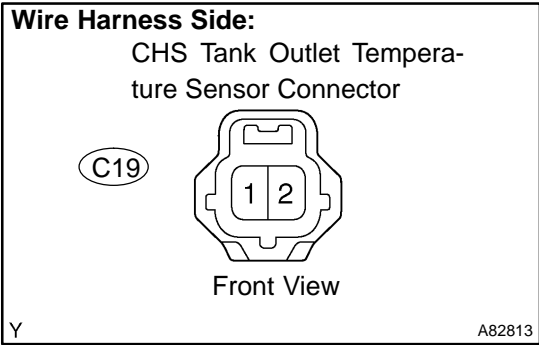

- (a) Check the harness and the connectors between the CHS tank outlet temperature sensor connector and the ECM connector.
- (1) Disconnect the C19 CHS tank outlet temperature sensor connector.
 - (2) Disconnect the E4 and E7 ECM connectors.
 - (3) Check the resistance between the wire harness side connectors.

Standard (Check for open):

Tester Connection	Specified Condition
CHS tank outlet temperature sensor (C19-2) - THW2 (E7-33)	Below 1 Ω
CHS tank outlet temperature sensor (C19-1) - E2 (E4-28)	Below 1 Ω

Standard (Check for short):

Tester Connection	Specified Condition
CHS tank outlet temperature sensor (C19-2) or THW2 (E7-33) - Body ground	10 kΩ or higher

- (4) Reconnect the CHS tank outlet temperature sensor connector.
- (5) Reconnect the ECM connectors.

NG REPAIR OR REPLACE HARNESS OR CONNECTOR

OK

REPLACE ECM (See page 10-24)